

Drills

Catalogue

Boring Tools

2022



ZCC Cutting Tools Europe GmbH

your Partner | your Value



WELCOME TO ZCC CUTTING TOOLS EUROPE

ZCC-CT, one of the World's leading carbide tooling manufacturers, welcomes you to its products. We are able to offer you a wide product range of high performance cutting tools at economic prices and a good supply service to support the production and productivity at your manufacturing facilities. You will find the main tool types in the various sections of the catalogue, Turning is in section A, Milling in section B and Drilling in section C of the catalogue.

We are looking forward to working with you and developing good cooperation together. Our team at ZCC Cutting Tools Europe is ready to support you in all of your requirements.



Member of Minmetals Group



EUROPEAN HEADQUARTER / HAUPTSITZ IN EUROPA:

ZCC Cutting Tools GmbH, Heltorfer Str.12, 40472 Düsseldorf, Germany

Tel.: +49 (0) 211/989240-0, Fax: +49 (0) 211/ 989240-111

E-Mail: info@zccct-europe.com, www.zccct-europe.com, www.zccct.com





Contents



A Turning A1-A333

General turning tools	A21-A246
Parting and grooving tools	A247-A290
Threading tools	A291-A325



B Milling B1-B592

Indexable milling tools	B1-B240
Solid carbide end mills	B241-B592

C Boring tools C1-C184

Drills	C1-C143
Reamers	C144-C155
Thread cutters	C156-C184





GD series

**Twist Drills for
General Machining**



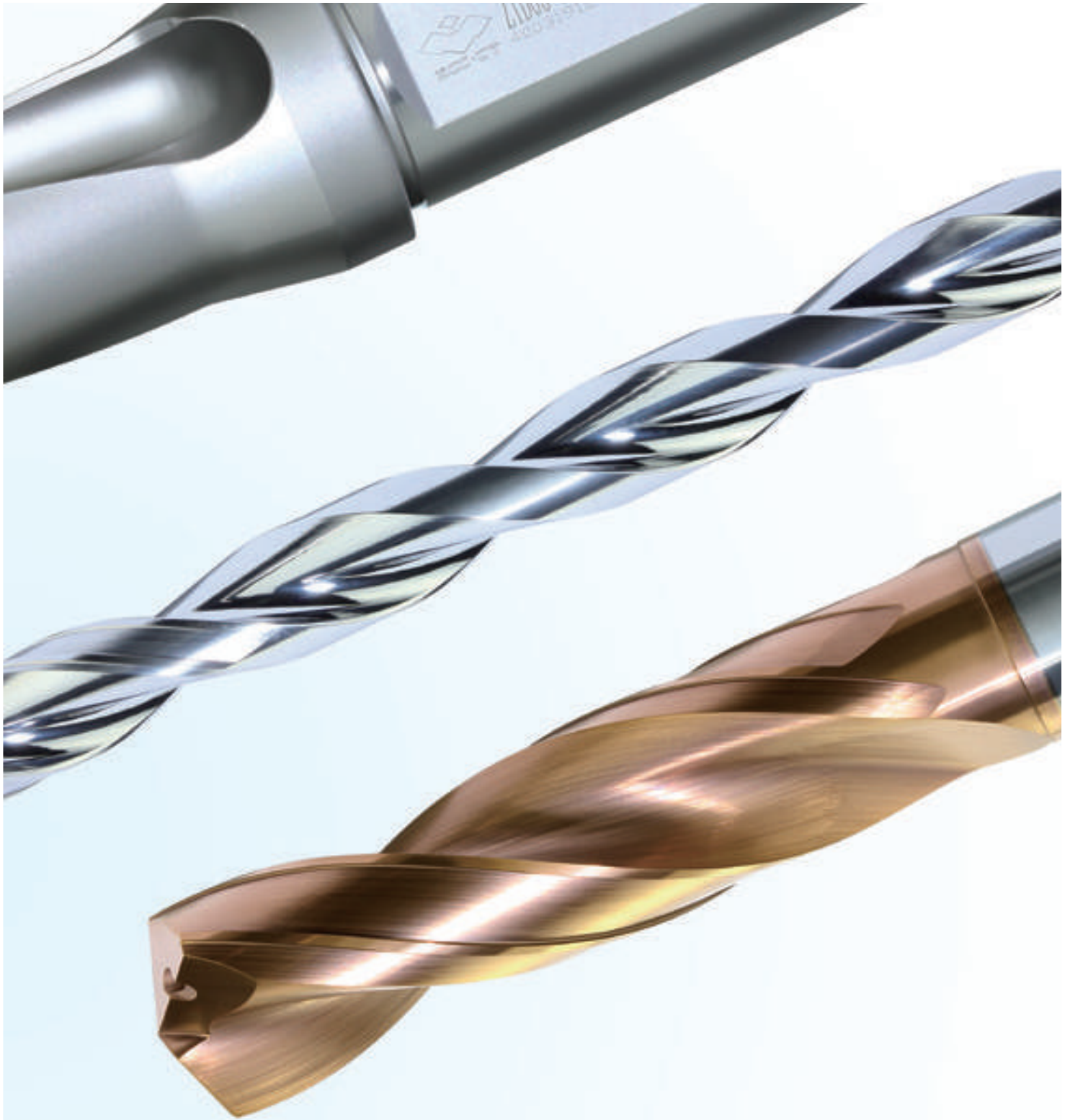

Boring Tools

*Drills
Reamers
Threading tools*



ZSD

U drill new series

Boring Tools



Drills

	C2-C143
Solid carbide drills	C2-C98
Indexable U drill	C99-C129
Interchangeable head drills	C130-C143

Reamers

	C144-C155
Solid carbide reamers	C144-C155

Threading tools

	C156-C184
Solid carbide threading cutters	C162-C173
Solid carbide threading end mills	C174-C175
Recommended cutting parameters of solid carbide threading tools	C176
Technical information	C177-C182
Non-standard customization for solid carbide taps	C183
Non-standard customization for solid carbide thread milling cutters	C184



How to choose the right solid carbide drills

How to choose the right solid carbide drills



- First choice for drilling soft steel and stainless steel.
- Sharp cutting edge can avoid build-up edge, suitable for drilling hole with high performance.

Drill diameter d ₁ (mm)	Drilling depth (L/d)	Cooling mode	Shank type	Type	Basic dimension(mm)				Recommended grade	
					Shank diameter d ₂ (mm)	Overall length l ₁	Flute length l ₂	Recommended drilling depth l ₃		Shank length l ₄
3.0	3	Internal coolant	Straight shank	1534ST03C-0300	6	62	20	14	36	☆
	5			1536ST05C-0300	6	66	28	23	36	☆
5	Whistle notch shank		1736ST05C-0300	6	66	28	23	36	☆	
3			1534ST03C-0310	6	62	20	14	36	☆	
3.1	5		Whistle notch shank	1536ST05C-0310	6	66	28	23	36	☆
	5			1736ST05C-0310	6	66	28	23	36	☆
3.2	3		Straight shank	1534ST03C-0320	6	62	20	14	36	☆
	5			1536ST05C-0320	6	66	28	23	36	☆
3.25	5		Whistle notch shank	1736ST05C-0320	6	66	28	23	36	☆
	3			1534ST03C-0325	6	62	20	14	36	☆
3.3	5		Whistle notch shank	1536ST05C-0325	6	66	28	23	36	☆
	3			1534ST03C-0330	6	62	20	14	36	☆
3.4	5	Whistle notch shank	1736ST05C-0330	6	66	28	23	36	☆	
	3		1534ST03C-0340	6	62	20	14	36	☆	
3.5	5	Whistle notch shank	1536ST05C-0340	6	66	28	23	36	☆	
	3		1534ST03C-0350	6	62	20	14	36	☆	
	5		1736ST05C-0350	6	66	28	23	36	☆	

☆ Recommended grade (produce according to order)

Grade	Workpiece material										
	Mild steel HBs180	Carbon steel, Alloy steel	Pre-hardened steel, Hardened steel			Stainless steel	Cast iron	Nodular cast iron	Aluminum alloy	Copper alloy	Heat resistant alloy
KDG303	○	○				○					○

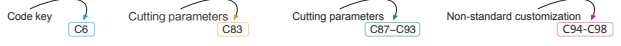

Applicable workpiece material range

Specifications
Type, depth of drilling, cooling system, type of shank, basic dimensions and grade.

Product features

Code key, cutting parameters, technical information, non-standard customization



BORING TOOL



Drills



Drilling tools overview	C4
Solid carbide drills	C5-C98
Grade introduction for solid carbide drills	C5
Solid carbide drills code key	C6
Solid carbide drills overview	C9-C78
Recommended cutting parameters for solid carbide drills	C79-C86
Technical information for solid carbide drills	C87-C93
Non-standard customization tools	C94-C98
Indexable U drill	C99-C129
U drills code key	C100
U drills overview	C103-C121
U drills code key	C122-C123
U drills inserts overview	C124-C126
Technical information for U drills	C127
Recommended cutting parameters for U drills	C128-129
Interchangeable head drills	C130-C143
Interchangeable head drills code key	C131
Interchangeable head drill tool holders overview	C132-C135
Interchangeable head drills overview	C136-C140
Technical information for interchangeable head drills	C141-C142
Recommended cutting parameters for interchangeable head drills	C143























BORING TOOL

Drilling Tools

Drilling tools overview

Drilling tools overview

Application	Type of drills	Type	Shape of drills	Coolant mode	Diameter range	Workpiece material						Page	
						P	M	K	N	S	H	Specification	Cutting parameters
						Soft steel	Common steel	Stainless steel	Cast iron	Non-ferrous metal	Heat resistant alloy		
General machining	Twist drill	GD03		External cooling	Ø2-Ø25	○	⊙	○	⊙	○	○	C9-C44	C79-C80
		GD03C		Internal cooling	Ø3-Ø25	○	⊙	○	⊙	○	○		
		GD05		External cooling	Ø2-Ø25	○	⊙	○	⊙	○	○		
		GD05C		Internal cooling	Ø3-Ø25	○	⊙	○	⊙	○	○		
		GD08C		Internal cooling	Ø3-Ø18	○	⊙	○	⊙	○	○		
Deep drilling	Twist drill	1588SL 12/20/30C		Internal cooling	Ø3-Ø20	○	⊙	○	⊙	○	C48-C51	C81	
Guide hole drilling	Twist drill	1534SP		Internal cooling	Ø3-Ø14	○	⊙	○	⊙	○	C52-C53	C82	
For soft steel, stainless steel	Twist drill	1534ST03C		Internal cooling	Ø3-Ø20	⊙	○	⊙		○	C55-C67	C83	
		1536ST05C		Internal cooling	Ø3-Ø20	⊙	○	⊙		○			
		1736ST05C		Internal cooling	Ø3-Ø20	⊙	○	⊙		○			
For aluminum, cast iron	Twist drill	1105SC03		External cooling	Ø2-Ø16				⊙	⊙	C68-71	C83	
		1101SC05		External cooling	Ø2-Ø16				⊙	⊙			
	Three flute drill	1165PA03		External cooling	Ø3-Ø20			○	⊙	⊙	○	C72-C75	C84
		1576PC05		External cooling	Ø4-Ø20				⊙	⊙		C76-C77	C85
	Straight flute drill	1579PC15C		Internal cooling	Ø5-Ø14				⊙	⊙			
		Centering drill	1143SC90		External cooling	Ø5-Ø20				⊙	⊙		C78
1143SC120			External cooling	Ø5-Ø20				⊙	⊙				
Indexable drills series	U drill	ZSD 02/03/04/05		Internal cooling	Ø12-Ø50	⊙	⊙	⊙	⊙	○	C103-C114	C130-C129	
		ZTD 02/03/04/05		Internal cooling	Ø13-Ø50	⊙	⊙	○	⊙	○		C118-C121	C130-C129
Interchangeable head drills series	Interchangeable head drills	ZTK 015/03/04/08		Internal cooling	Ø12-Ø25	○	⊙	○	⊙	⊙	C132-C135	C151	

⊙Very suitable ○Suitable

Drilling tools

Drilling tools overview



Grade introduction of solid carbide drills

Coated grade

KDG3013

New AlCrN substrate composite coating, with excellent abrasion resistance and bonding resistance, improves the stability of the insert edge.

Unique coating after-treatment technology effectively reduces the cutting resistance for smoother chip evacuation and higher security.

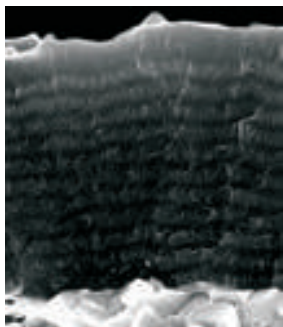

AlCrN substrate composite coating



KDG3013



Conventional coating

KDG303

Ultra-fine carbide substrate with high strength, toughness and wear resistance, in combination with nano-structured nc-TiAlN coating aiming at optimizing drilling operations, makes sure the tools have very high toughness and hardness. Unique coating technology gives the tools smooth surface and excellent wear resistance, and outstanding thermal stability and chemical stability provide effective protection for the cutting edge.



Common TiAlN coating



nc-TiAlN coating

Uncoated grade

YK20F

Ultra-fine grain carbide substrate with high hardness, outstanding wear resistance, and long tool life.

YK30F

Ultra-fine carbide substrate with high strength, toughness and wear resistance gives the cutting edge perfect strength.



BORING TOOL / Drilling Tools

Solid carbide drills code key

Solid carbide drills code key

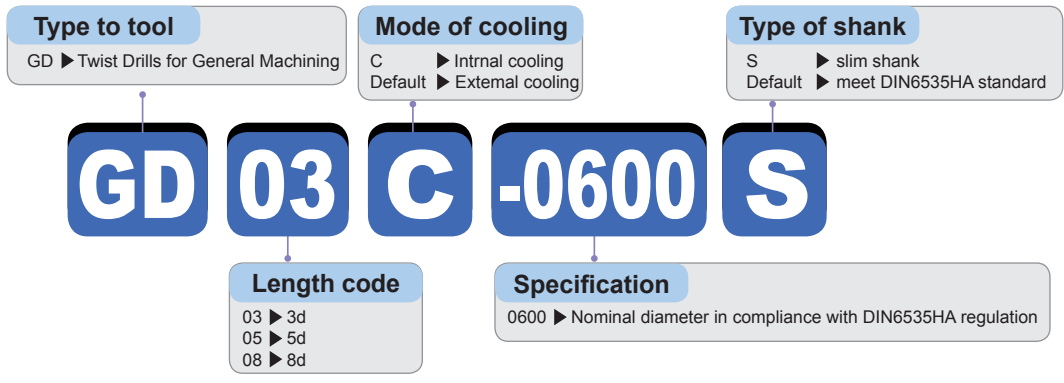

Code	Description
1	As per DIN338
2	As per DIN1897
3	As per QJ/ZZQ(TO)01.001.002
4	As per DIN6537K
5	As per DIN6537K
6	As per DIN6537K
7	As per the rule ZCC-C in QJ/ZZQ(TO)01.001.002
8	As per the rule ZCC-D in QJ/ZZQ(TO)01.001.002
9	As per the rule ZCC-E in QJ/ZZQ(TO)01.001.002

Length code

Code	Description
SL	Deep twist drills
ST	Twist drill for soft steel, stainless steel
SC	Twist drill for AL alloy and cast iron
PA	Three flute drill for AL alloy and cast iron
PC	Straight flute drill for aluminum, cast iron

Geometry

Code	Description
1	Drills

Type to tool

Code	Description
C	Internal coolant
Default	External coolant

Mode of cooling



Code	Description
1	Straight shank
2	Square head straight shank as per DIN10
3	Double flattened straight shank as per DIN1809
5	Straight shank as per DIN6535HA
7	Whistle notch shank as per DIN6535HE
9	Tapered shank

Type of shank

Code	Description
0	Twist drill
3	Multiple functions twist drill
4	Centering drill
5	Step drill
7	Straight flute drill
8	Deep drill

Type of drill

Code	Description
0850	Nominal diameter of drill

Specification

Cutting depth shown when the tool is non-pilot drill		Point angle identification shown when tool is pilot drill	
Code	Description	Code	Description
03	(2~3) d	90	pilot drill with 90° point angle
05	(4~5) d		
08	(7~8) d		
12	(12) d	120	pilot drill with 120° point angle
15	(15) d		
20	(20) d		
30	(30) d		

Drilling tools

Solid carbide drills code key



G.D. series Twist Drills for General Machining

Application range

Versatile, for high efficiency machining in a variety of material e.g. P(steel), M(stainless steel), K (Cast iron).



- Linear cutting edge with high strength.
Optimized drill point structure for better cutting performance.

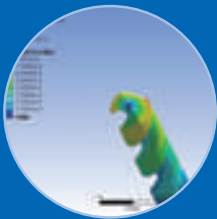

- Simulation in combination with testing for superior overall performance.



- Professional after treatment for coating ensures low-resistance high-efficiency machining.



- Double edge-line design for improved machining stability.



Long and stable tool life

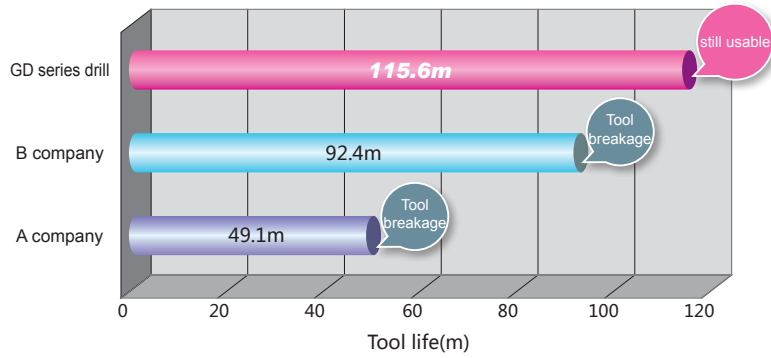

tool: GD05C-0560
 workpiece material: C70S6(HRC30)
 $V_c=100\text{m/min}$; $f=0.15\text{mm/r}$; $H=27\text{mm}$
 cooling system: water soluble cooling

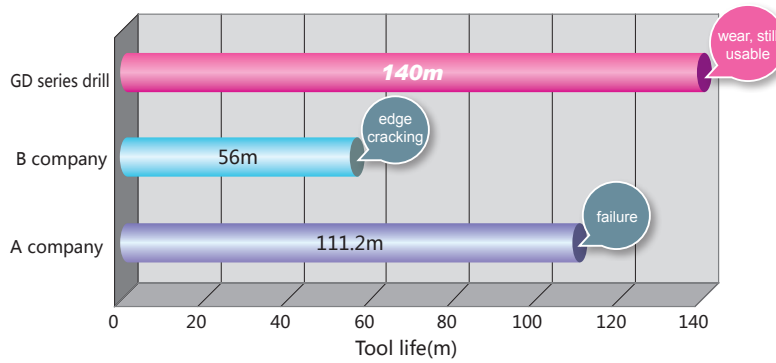

tool: GD05C-1000
 workpiece material: 45#steel(HB180)
 $V_c=150\text{m/min}$; $f=0.25\text{mm/r}$; $H=40\text{mm}$
 cooling system: water soluble cooling

outstanding machining precision

quality of hole wall:

tool: GD03C-0820
 workpiece material: C70S6(HRC30)
 $V_c=120\text{m/min}$; $f=0.23\text{mm/r}$; $H=30\text{mm}$;
 cooling system: water soluble cooling



GD series drill



A company

excellent chip breaking performance

chip breaking performance:

tool: GD05C-0600
 workpiece material: 1Cr18Ni9Ti(HB180)
 $V_c=75\text{m/min}$; $f=0.2\text{mm/r}$; $H=30\text{mm}$;
 cooling system: water soluble cooling



GD series drill



A company



GD series General machining

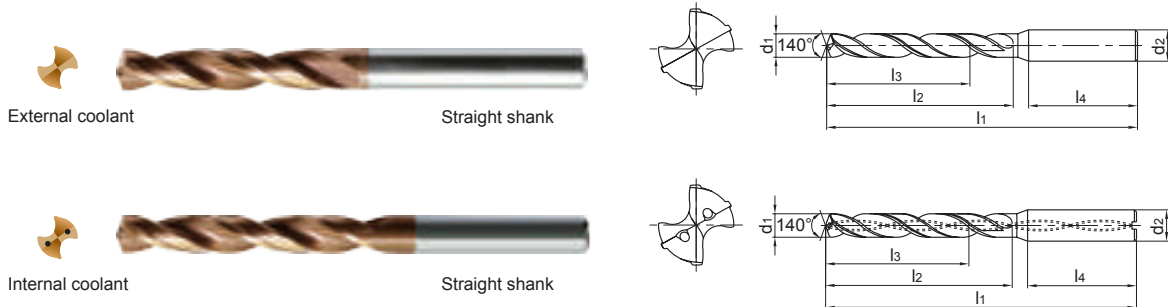

● Suitable for high efficiency drilling in a variety of materials e.g steel, stainless steel, cast iron.

Drill diameter d1(m7)	Drilling depth (l/d)	Cooling mode	Shank type	Type	Basic dimension(mm)					Suitable for thread		Grade
					Shank diameter	Overall length	Flute length	Recommended drilling depth	Shank length	cutting taps / tread milling cutters	forming taps	
					d2(h6)	l1	l2	l3	l4			
2.0	3	External coolant	Straight shank	GD03-0200S	3	58	13	9	28	NO.2-64UNF	○	
	5			GD05-0200S	3	58	18	14	28		○	
	3			GD03-0200	4	58	13	9	28		●	
	5			GD05-0200	4	58	18	14	28		●	
2.1	3			NO.3-48UNC	GD03-0210S	3	58	13	9	28	○	
	5				GD05-0210S	3	58	18	14	28	○	
	3				GD03-0210	4	58	13	9	28	●	
	5				GD05-0210	4	58	18	14	28	●	
2.15	3			NO.3-56UNF	GD03-0215S	3	58	13	9	28	○	
	5				GD05-0215S	3	58	18	14	28	○	
	3				GD03-0215	4	58	13	9	28	●	
	5				GD05-0215	4	58	18	14	28	●	
2.2	3		GD03-0220S	3	58	13	9	28	○			
	5		GD05-0220S	3	58	18	14	28	○			
	3		GD03-0220	4	58	13	9	28	●			
	5		GD05-0220	4	58	18	14	28	●			
2.3	3		GD03-0230S	3	58	13	9	28	○			
	5		GD05-0230S	3	58	18	14	28	○			
	3		GD03-0230	4	58	13	9	28	●			
	5		GD05-0230	4	58	18	14	28	●			

● Stock available ○ Make-to-order

Drilling tools

GD series

▶▶ Applicable material table

● Very suitable ○ Suitable

Grade	Workpiece material										
	Mild steel HB ≤ 180	Carbon steel, Alloy steel	Pre-hardened steel, Hardened steel			Stainless steel	Cast iron	Nodular cast iron	Aluminum alloy	Copper alloy	Heat resistant alloy
			~40HRC	~50HRC	~60HRC						
KDG3013	○	●	●			○	●	●			○

Code key C6 Cutting parameters C79-C80 Technical information C87-C93 Non-standard customization tools C94-C98



BORING TOOL / Drilling Tools

GD series

GD series General machining

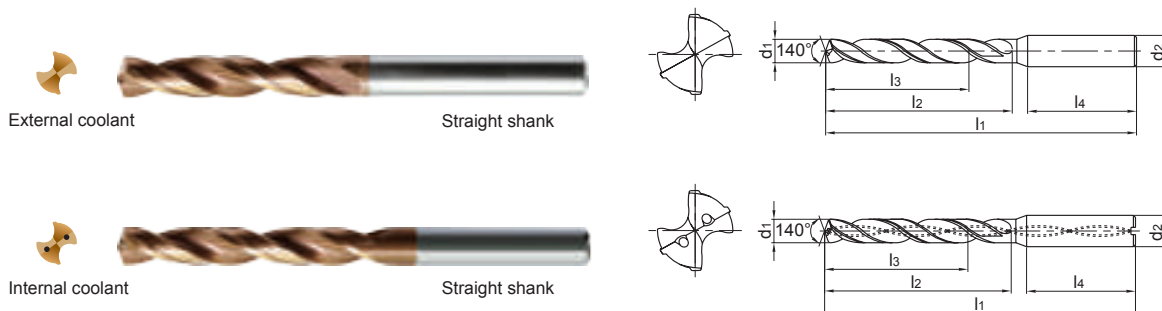

● Suitable for high efficiency drilling in a variety of materials e.g steel, stainless steel, cast iron.

Drill diameter d1(m7)	Drilling depth (l/d)	Cooling mode	Shank type	Type	Basic dimension(mm)					Suitable for thread		Grade
					Shank diameter	Overall length	Flute length	Recommended drilling depth	Shank length	cutting taps / tread milling cutters	forming taps	
					d2(h6)	l1	l2	l3	l4			
2.35	3	External coolant	Straight shank	GD03-0235S	3	58	17	12	28	NO.4-40UNC		○
	5			GD05-0235S	3	58	22	17	28			○
	3			GD03-0235	4	58	17	12	28			●
	5			GD05-0235	4	58	22	17	28			●
2.4	3			GD03-0240S	3	58	17	12	28	NO.4-48UNF		○
	5			GD05-0240S	3	58	22	17	28			○
	3			GD03-0240	4	58	17	12	28			●
	5			GD05-0240	4	58	22	17	28			●
2.5	3			GD03-0250S	3	58	17	12	28	M3x0.5		○
	5			GD05-0250S	3	58	22	17	28			○
	3			GD03-0250	4	58	17	12	28			●
	5			GD05-0250	4	58	22	17	28			●
2.55	3			GD03-0255S	3	58	17	12	28	NO.4-40UNC		○
	5			GD05-0255S	3	58	22	17	28			○
	3			GD03-0255	4	58	17	12	28			●
	5			GD05-0255	4	58	22	17	28			●
2.6	3	GD03-0260S	3	58	17	12	28	NO.4-48UNF		○		
	5	GD05-0260S	3	58	22	17	28			○		
	3	GD03-0260	4	58	17	12	28			●		
	5	GD05-0260	4	58	22	17	28			●		
2.65	3	GD03-0265S	3	58	17	12	28	NO.5-40UNC		○		
	5	GD05-0265S	3	58	22	17	28			○		
	3	GD03-0265	4	58	17	12	28			●		
	5	GD05-0265	4	58	22	17	28			●		
2.7	3	GD03-0270S	3	58	17	12	28	NO.5-44UNF		○		
	5	GD05-0270S	3	58	22	17	28			○		
	3	GD03-0270	4	58	17	12	28			●		
	5	GD05-0270	4	58	22	17	28			●		

● Stock available ○ Make-to-order

Drilling tools

GD series



Drill diameter d ₁ (m7)	Drilling depth (l/d)	Cooling mode	Shank type	Type	Basic dimension(mm)					Suitable for thread		Grade					
					Shank diameter	Overall length	Flute length	Recommended drilling depth	Shank length	cutting taps / tread milling cutters	forming taps						
					d ₂ (h ₆)	l ₁	l ₂	l ₃	l ₄								
2.8	3	External coolant	Straight shank	GD03-0280S	3	58	17	12	28	M3×0.5	○						
	5			GD05-0280S	3	58	22	17	28		○						
	3			GD03-0280	4	58	17	12	28		●						
	5			GD05-0280	4	58	22	17	28		●						
2.85	3			External coolant	Straight shank	GD03-0285S	3	58	17	12	28	NO.6-32UNC	○				
	5					GD05-0285S	3	58	22	17	28		○				
	3					GD03-0285	4	58	17	12	28		●				
	5					GD05-0285	4	58	22	17	28		●				
2.9	3					External coolant	Straight shank	GD03-0290S	3	58	17	12	28	NO.5-40UNC	○		
	5							GD05-0290S	3	58	22	17	28		○		
	3							GD03-0290	4	58	17	12	28		●		
	5							GD05-0290	4	58	22	17	28		●		
2.95	3							External coolant	Straight shank	GD03-0295S	3	58	17	12	28	NO.6-40UNF	○
	5									GD05-0295S	3	58	22	17	28		○
	3									GD03-0295	4	58	17	12	28		●
	5									GD05-0295	4	58	22	17	28		●
3.0	3	Internal coolant	Straight shank							GD03-0300S	3	62	20	14	36		○
	5									GD05-0300S	3	66	28	23	36		○
	3									GD03C-0300S	3	62	20	14	36		○
	5									GD05C-0300S	3	66	28	23	36		○
	3			GD03-0300	6					62	20	14	36	●			
	5			GD05-0300	6					66	28	23	36	●			
	3			GD03C-0300	6					62	20	14	36	●			
	5			GD05C-0300	6					66	28	23	36	●			
3.1	8	Internal coolant	Straight shank	GD08C-0300	6	72	34			29	36		○				
	3			External coolant	GD03-0310S	4	62			20	14		36	●			
	5				GD05-0310S	4	66			28	23		36	●			
	3			Internal coolant	GD03C-0310S	4	62			20	14		36	●			
	5				GD05C-0310S	4	66	28	23	36	●						
	3			External coolant	GD03-0310	6	62	20	14	36	○						
	5				GD05-0310	6	66	28	23	36	○						
	3			Internal coolant	GD03C-0310	6	62	20	14	36	○						
5	GD05C-0310	6	66		28	23	36	○									
8	Internal coolant	GD08C-0310	6	72	34	29	36	○									

Note: For drilling depth (l/d) of 8 ,namely GD08C series, tolerance of shank diameter is h₈. ● Stock available ○ Make-to-order

Drilling tools

GD series

➤ Applicable material table

● Very suitable ○ Suitable

Grade	Workpiece material										
	Mild steel HB ≤ 180	Carbon steel, Alloy steel	Pre-hardened steel, Hardened steel			Stainless steel	Cast iron	Nodular cast iron	Aluminum alloy	Copper alloy	Heat resistant alloy
			~40HRC	~50HRC	~60HRC						
KDG3013	○	●	●			○	●	●			○

Code key

C6

Cutting parameters
C79-C80

Technical information
C87-C93

Non-standard customization tools
C94-C98



BORING TOOL / Drilling Tools

GD series

GD series General machining

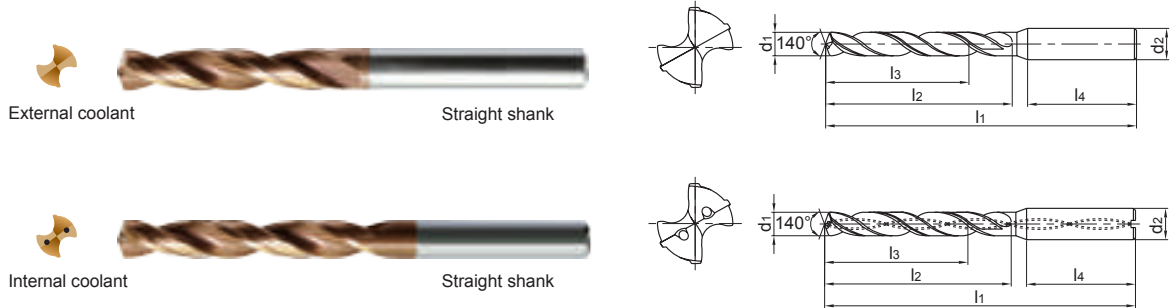

● Suitable for high efficiency drilling in a variety of materials e.g steel, stainless steel, cast iron.

Drill diameter d1(m7)	Drilling depth (l/d)	Cooling mode	Shank type	Type	Basic dimension(mm)					Suitable for thread		Grade
					Shank diameter d2(h6)	Overall length l1	Flute length l2	Recommended drilling depth l3	Shank length l4	cutting taps / tread milling cutters	forming taps	
3.15	3	External coolant	Straight shank	GD03-0315S	4	62	20	14	36	NO.6-32UNC	●	
	5			GD05-0315S	4	66	28	23	36		●	
	3	Internal coolant		GD03C-0315S	4	62	20	14	36		●	
	5			GD05C-0315S	4	66	28	23	36		●	
	3	External coolant		GD03-0315	6	62	20	14	36		○	
	5			GD05-0315	6	66	28	23	36		○	
	3	Internal coolant		GD03C-0315	6	62	20	14	36		○	
	5			GD05C-0315	6	66	28	23	36		○	
3.2	3	External coolant	GD03-0320S	4	62	20	14	36	NO.6-40UNF	●		
	5		GD05-0320S	4	66	28	23	36		●		
	3	Internal coolant	GD03C-0320S	4	62	20	14	36		●		
	5		GD05C-0320S	4	66	28	23	36		●		
	3	External coolant	GD03-0320	6	62	20	14	36		○		
	5		GD05-0320	6	66	28	23	36		○		
	3	Internal coolant	GD03C-0320	6	62	20	14	36		○		
	5		GD05C-0320	6	66	28	23	36		○		
8		GD08C-0320	6	72	34	29	36	○				
3.25	3	External coolant	GD03-0325S	4	62	20	14	36		●		
	5		GD05-0325S	4	66	28	23	36		●		
	3	Internal coolant	GD03C-0325S	4	62	20	14	36		●		
	5		GD05C-0325S	4	66	28	23	36		●		
	3	External coolant	GD03-0325	6	62	20	14	36		○		
	5		GD05-0325	6	66	28	23	36		○		
	3	Internal coolant	GD03C-0325	6	62	20	14	36		○		
	5		GD05C-0325	6	66	28	23	36		○		

● Stock available ○ Make-to-order

Drilling tools

GD series



Drill diameter d ₁ (mm)	Drilling depth (l/d)	Cooling mode	Shank type	Type	Basic dimension(mm)					Suitable for thread		Grade	
					Shank diameter	Overall length	Flute length	Recommended drilling depth	Shank length	cutting taps / tread milling cutters	forming taps		
					d ₂ (h ₆)	l ₁	l ₂	l ₃	l ₄				
3.3	3	External coolant	Straight shank	GD03-0330S	4	62	20	14	36	M4×0.7		●	
	5			GD05-0330S	4	66	28	23	36			●	
	3	Internal coolant		GD03C-0330S	4	62	20	14	36			●	
	5			GD05C-0330S	4	66	28	23	36			●	
	3	External coolant		GD03-0330	6	62	20	14	36			○	
	5			GD05-0330	6	66	28	23	36			○	
	3	Internal coolant		GD03C-0330	6	62	20	14	36			○	
	5			GD05C-0330	6	66	28	23	36			○	
8		GD08C-0330	6	72	34	29	36	○					
3.4	3	External coolant	GD03-0340S	4	62	20	14	36			●		
	5		GD05-0340S	4	66	28	23	36			●		
	3	Internal coolant	GD03C-0340S	4	62	20	14	36			●		
	5		GD05C-0340S	4	66	28	23	36			●		
	3	External coolant	GD03-0340	6	62	20	14	36			○		
	5		GD05-0340	6	66	28	23	36			○		
	3	Internal coolant	GD03C-0340	6	62	20	14	36			○		
	5		GD05C-0340	6	66	28	23	36			○		
8		GD08C-0340	6	72	34	29	36	○					
3.5	3	External coolant	GD03-0350S	4	62	20	14	36	M4×0.5			●	
	5		GD05-0350S	4	66	28	23	36				●	
	3	Internal coolant	GD03C-0350S	4	62	20	14	36				●	
	5		GD05C-0350S	4	66	28	23	36				●	
	3	External coolant	GD03-0350	6	62	20	14	36				NO.8-32UNC	○
	5		GD05-0350	6	66	28	23	36				NO.8-36UNF	○
	3	Internal coolant	GD03C-0350	6	62	20	14	36				○	
	5		GD05C-0350	6	66	28	23	36				○	
8		GD08C-0350	6	72	34	29	36	○					
3.6	3	External coolant	GD03-0360S	4	62	20	14	36				●	
	5		GD05-0360S	4	66	28	23	36				●	
	3	Internal coolant	GD03C-0360S	4	62	20	14	36				●	
	5		GD05C-0360S	4	66	28	23	36				●	
	3	External coolant	GD03-0360	6	62	20	14	36				○	
	5		GD05-0360	6	66	28	23	36				○	
	3	Internal coolant	GD03C-0360	6	62	20	14	36				○	
	5		GD05C-0360	6	66	28	23	36				○	
8		GD08C-0360	6	72	34	29	36	○					

Note: For drilling depth (l/d) of 8, namely GD08C series, tolerance of shank diameter is h₈.

● Stock available ○ Make-to-order

➤ Applicable material table

● Very suitable ○ Suitable

Grade	Workpiece material										
	Mild steel HB ≤ 180	Carbon steel, Alloy steel	Pre-hardened steel, Hardened steel			Stainless steel	Cast iron	Nodular cast iron	Aluminum alloy	Copper alloy	Heat resistant alloy
			~40HRC	~50HRC	~60HRC						
KDG3013	○	●	●			○	●	●		○	

Code key
C6

Cutting parameters
C79-C80

Technical information
C87-C93

Non-standard customization tools
C94-C98

Drilling tools

GD series



BORING TOOL / Drilling Tools

GD series

GD series General machining

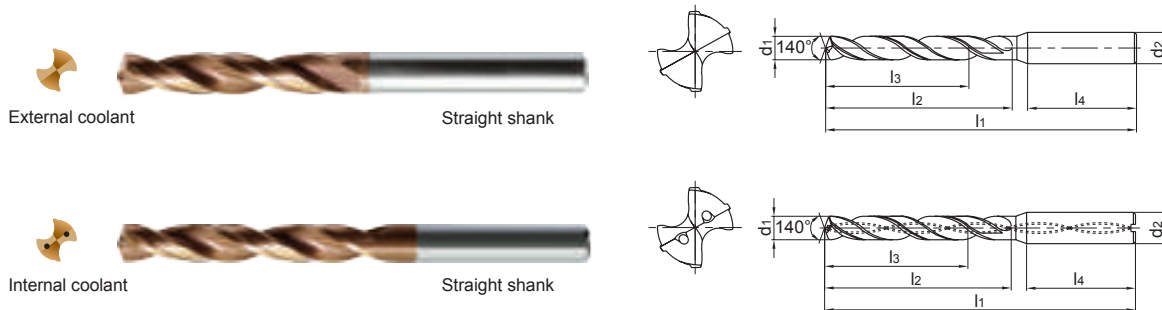

● Suitable for high efficiency drilling in a variety of materials e.g steel, stainless steel, cast iron.

Drill diameter d1(m7)	Drilling depth (l/d)	Cooling mode	Shank type	Type	Basic dimension(mm)					Suitable for thread		Grade
					Shank diameter d2(h6)	Overall length l1	Flute length l2	Recommended drilling depth l3	Shank length l4	cutting taps / tread milling cutters	forming taps	
3.7	3	External coolant	Straight shank	GD03-0370S	4	62	20	14	36	M4×0.7	●	
	5			GD05-0370S	4	66	28	23	36		●	
	3	Internal coolant		GD03C-0370S	4	62	20	14	36		●	
	5			GD05C-0370S	4	66	28	23	36		●	
	3	External coolant		GD03-0370	6	62	20	14	36		○	
	5			GD05-0370	6	66	28	23	36		○	
	3	Internal coolant		GD03C-0370	6	62	20	14	36		○	
	5			GD05C-0370	6	66	28	23	36		○	
8		GD08C-0370	6	72	34	29	36	○				
3.8	3	External coolant	Straight shank	GD03-0380S	4	66	24	17	36	M4×0.5 NO.8-32UNC	●	
	5			GD05-0380S	4	74	36	29	36		●	
	3	Internal coolant		GD03C-0380S	4	66	24	17	36		●	
	5			GD05C-0380S	4	74	36	29	36		●	
	3	External coolant		GD03-0380	6	66	24	17	36		○	
	5			GD05-0380	6	74	36	29	36		○	
	3	Internal coolant		GD03C-0380	6	66	24	17	36		○	
	5			GD05C-0380	6	74	36	29	36		○	
8		GD08C-0380	6	81	43	36	36	○				
3.85	3	External coolant	Straight shank	GD03-0385S	4	66	24	17	36	NO.8-36UNF	●	
	5			GD05-0385S	4	74	36	29	36		●	
	3	Internal coolant		GD03C-0385S	4	66	24	17	36		●	
	5			GD05C-0385S	4	74	36	29	36		●	
	3	External coolant		GD03-0385	6	66	24	17	36		○	
	5			GD05-0385	6	74	36	29	36		○	
	3	Internal coolant		GD03C-0385	6	66	24	17	36		○	
	5			GD05C-0385	6	74	36	29	36		○	

● Stock available ○ Make-to-order

Drilling tools

GD series



Drill diameter d ₁ (mm)	Drilling depth (l/d)	Cooling mode	Shank type	Type	Basic dimension(mm)					Suitable for thread		Grade
					Shank diameter	Overall length	Flute length	Recommended drilling depth	Shank length	cutting taps / tread milling cutters	forming taps	
					d ₂ (h ₆)	l ₁	l ₂	l ₃	l ₄			
3.9	3	External coolant	Straight shank	GD03-0390S	4	66	24	17	36	NO.10-24UNC		●
	5			GD05-0390S	4	74	36	29	36			●
	3	Internal coolant		GD03C-0390S	4	66	24	17	36			●
	5			GD05C-0390S	4	74	36	29	36			●
	3	External coolant		GD03-0390	6	66	24	17	36			○
	5			GD05-0390	6	74	36	29	36			○
	3	Internal coolant		GD03C-0390	6	66	24	17	36			○
	5			GD05C-0390	6	74	36	29	36			○
8	GD08C-0390	6		81	43	36	36	○				
4.0	3	External coolant		GD03-0400S	4	66	24	17	36			●
	5			GD05-0400S	4	74	36	29	36			●
	3	Internal coolant		GD03C-0400S	4	66	24	17	36			●
	5			GD05C-0400S	4	74	36	29	36			●
	3	External coolant		GD03-0400	6	66	24	17	36			○
	5			GD05-0400	6	74	36	29	36			○
	3	Internal coolant		GD03C-0400	6	66	24	17	36			○
	5		GD05C-0400	6	74	36	29	36	○			
8	GD08C-0400	6	81	43	36	36	○					
4.1	3	External coolant	GD03-0410S	5	66	24	17	36	NO.10-32UNF		○	
	5		GD05-0410S	5	74	36	29	36			○	
	3	Internal coolant	GD03C-0410S	5	66	24	17	36			○	
	5		GD05C-0410S	5	74	36	29	36			○	
	3	External coolant	GD03-0410	6	66	24	17	36			●	
	5		GD05-0410	6	74	36	29	36			●	
	3	Internal coolant	GD03C-0410	6	66	24	17	36			●	
	5		GD05C-0410	6	74	36	29	36			●	
8	GD08C-0410	6	81	43	36	36	○					
4.2	3	External coolant	GD03-0420S	5	66	24	17	36	M5×0.8		○	
	5		GD05-0420S	5	74	36	29	36			○	
	3	Internal coolant	GD03C-0420S	5	66	24	17	36			○	
	5		GD05C-0420S	5	74	36	29	36			○	
	3	External coolant	GD03-0420	6	66	24	17	36			●	
	5		GD05-0420	6	74	36	29	36			●	
	3	Internal coolant	GD03C-0420	6	66	24	17	36			●	
	5		GD05C-0420	6	74	36	29	36			●	
8	GD08C-0420	6	81	43	36	36	○					

Note: For drilling depth (l/d) of 8 ,namely GD08C series, tolerance of shank diameter is h₈.

● Stock available ○ Make-to-order

➤ Applicable material table

⊙ Very suitable ○ Suitable

Grade	Workpiece material										
	Mild steel HB ≤ 180	Carbon steel, Alloy steel	Pre-hardened steel, Hardened steel			Stainless steel	Cast iron	Nodular cast iron	Aluminum alloy	Copper alloy	Heat resistant alloy
			~40HRC	~50HRC	~60HRC						
KDG3013	○	⊙	⊙			○	⊙	⊙		○	

Code key

C6

Cutting parameters

C79-C80

Technical information

C87-C93

Non-standard customization tools

C94-C98

Drilling tools

GD series



BORING TOOL / Drilling Tools

GD series

GD series General machining

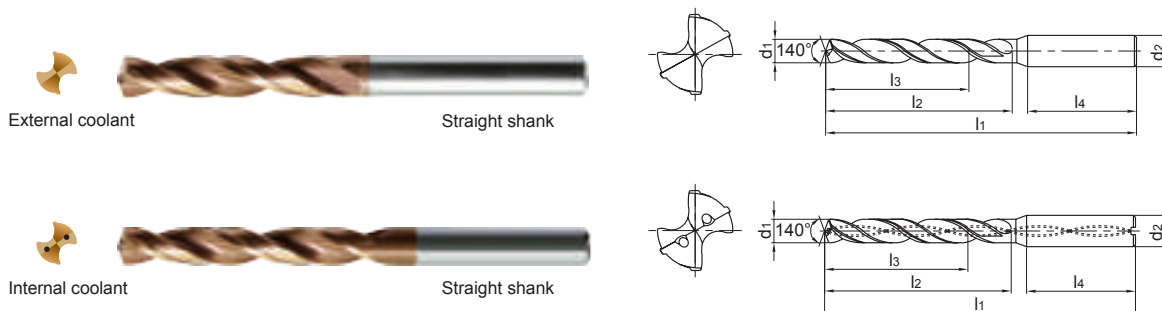

● Suitable for high efficiency drilling in a variety of materials e.g steel, stainless steel, cast iron.

Drill diameter d1(m7)	Drilling depth (l/d)	Cooling mode	Shank type	Type	Basic dimension(mm)					Suitable for thread		Grade
					Shank diameter	Overall length	Flute length	Recommended drilling depth	Shank length	cutting taps / tread milling cutters	forming taps	
					d2(h6)	l1	l2	l3	l4			
4.3	3	External coolant	Straight shank	GD03-0430S	5	66	24	17	36			○
	5			GD05-0430S	5	74	36	29	36			○
	3	Internal coolant		GD03C-0430S	5	66	24	17	36			○
	5			GD05C-0430S	5	74	36	29	36			○
	3	External coolant		GD03-0430	6	66	24	17	36			●
	5			GD05-0430	6	74	36	29	36			●
	3	Internal coolant		GD03C-0430	6	66	24	17	36			●
	5			GD05C-0430	6	74	36	29	36			●
4.35	8		GD08C-0430	6	81	43	36	36			○	
	3	External coolant	GD03-0435S	5	66	24	17	36			○	
	5		GD05-0435S	5	74	36	29	36			○	
	3	Internal coolant	GD03C-0435S	5	66	24	17	36			○	
	5		GD05C-0435S	5	74	36	29	36		NO.10-24UNC	○	
	3	External coolant	GD03-0435	6	66	24	17	36			●	
	5		GD05-0435	6	74	36	29	36			●	
	3	Internal coolant	GD03C-0435	6	66	24	17	36			●	
5	GD05C-0435		6	74	36	29	36			●		
4.4	3	External coolant	GD03-0440S	5	66	24	17	36			○	
	5		GD05-0440S	5	74	36	29	36			○	
	3	Internal coolant	GD03C-0440S	5	66	24	17	36			○	
	5		GD05C-0440S	5	74	36	29	36			○	
	3	External coolant	GD03-0440	6	66	24	17	36			●	
	5		GD05-0440	6	74	36	29	36			●	
	3	Internal coolant	GD03C-0440	6	66	24	17	36			●	
	5		GD05C-0440	6	74	36	29	36			●	
8		GD08C-0440	6	81	43	36	36			○		

● Stock available ○ Make-to-order

Drilling tools

GD series



Drill diameter d ₁ (m7)	Drilling depth (l/d)	Cooling mode	Shank type	Type	Basic dimension(mm)					Suitable for thread		Grade
					Shank diameter	Overall length	Flute length	Recommended drilling depth	Shank length	cutting taps / tread milling cutters	forming taps	
					d ₂ (h6)	l ₁	l ₂	l ₃	l ₄			
4.45	3	External coolant	Straight shank	GD03-0445S	5	66	24	17	36	NO.10-32UNF		○
	5			GD05-0445S	5	74	36	29	36			○
	3	Internal coolant		GD03C-0445S	5	66	24	17	36			○
	5			GD05C-0445S	5	74	36	29	36			○
	3	External coolant		GD03-0445	6	66	24	17	36			●
	5			GD05-0445	6	74	36	29	36			●
	3	Internal coolant		GD03C-0445	6	66	24	17	36			●
	5			GD05C-0445	6	74	36	29	36			●
4.5	3	External coolant	GD03-0450S	5	66	24	17	36	NO.12-24UNC M5×0.5		○	
	5		GD05-0450S	5	74	36	29	36			○	
	3	Internal coolant	GD03C-0450S	5	66	24	17	36			○	
	5		GD05C-0450S	5	74	36	29	36			○	
	3	External coolant	GD03-0450	6	66	24	17	36			●	
	5		GD05-0450	6	74	36	29	36			●	
	3	Internal coolant	GD03C-0450	6	66	24	17	36			●	
	5		GD05C-0450	6	74	36	29	36			●	
4.6	3	External coolant	GD03-0460S	5	66	24	17	36			○	
	5		GD05-0460S	5	74	36	29	36			○	
	3	Internal coolant	GD03C-0460S	5	66	24	17	36			○	
	5		GD05C-0460S	5	74	36	29	36			○	
	3	External coolant	GD03-0460	6	66	24	17	36			●	
	5		GD05-0460	6	74	36	29	36			●	
	3	Internal coolant	GD03C-0460	6	66	24	17	36			●	
	5		GD05C-0460	6	74	36	29	36			●	
4.65	3	External coolant	GD03-0465S	5	66	24	17	36	M5×0.8		○	
	5		GD05-0465S	5	74	36	29	36			○	
	3	Internal coolant	GD03C-0465S	5	66	24	17	36			○	
	5		GD05C-0465S	5	74	36	29	36			○	
	3	External coolant	GD03-0465	6	66	24	17	36			●	
	5		GD05-0465	6	74	36	29	36			●	
	3	Internal coolant	GD03C-0465	6	66	24	17	36			●	
	5		GD05C-0465	6	74	36	29	36			●	

Note: For drilling depth (l/d) of 8 ,namely GD08C series, tolerance of shank diameter is h₈.

● Stock available ○ Make-to-order

Drilling tools

GD series

➤ Applicable material table

⊙Very suitable ○Suitable

Grade	Workpiece material										
	Mild steel HB ≤ 180	Carbon steel, Alloy steel	Pre-hardened steel, Hardened steel			Stainless steel	Cast iron	Nodular cast iron	Aluminum alloy	Copper alloy	Heat resistant alloy
			~40HRC	~50HRC	~60HRC						
KDG3013	○	⊙	⊙			○	⊙	⊙			○

Code key

C6

Cutting parameters
C79-C80

Technical information
C87-C93

Non-standard customization tools
C94-C98



BORING TOOL / Drilling Tools

GD series

GD series General machining

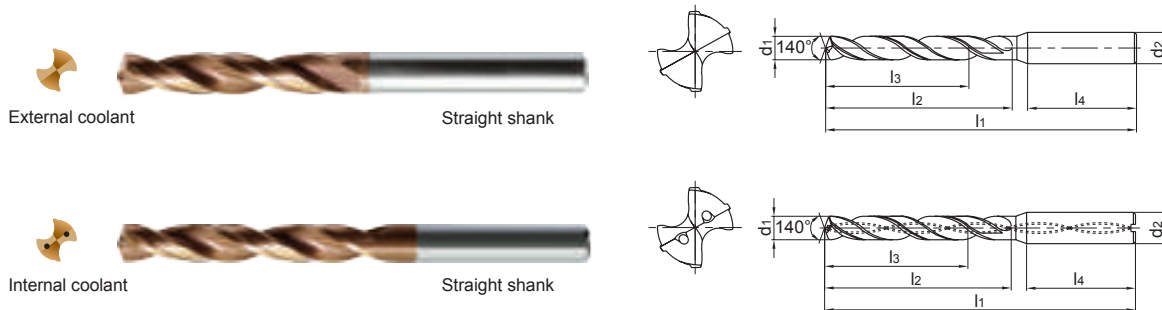

● Suitable for high efficiency drilling in a variety of materials e.g steel, stainless steel, cast iron.

Drill diameter d1(m7)	Drilling depth (l/d)	Cooling mode	Shank type	Type	Basic dimension(mm)					Suitable for thread		Grade
					Shank diameter d2(h6)	Overall length l1	Flute length l2	Recommended drilling depth l3	Shank length l4	cutting taps / tread milling cutters	forming taps	
4.7	3	External coolant	Straight shank	GD03-0470S	5	66	24	17	36	NO.12-28UNF		○
	5			GD05-0470S	5	74	36	29	36			○
	3	Internal coolant		GD03C-0470S	5	66	24	17	36			○
	5			GD05C-0470S	5	74	36	29	36			○
	3	External coolant		GD03-0470	6	66	24	17	36			●
	5			GD05-0470	6	74	36	29	36			●
	3	Internal coolant		GD03C-0470	6	66	24	17	36			●
	5			GD05C-0470	6	74	36	29	36			●
8		GD08C-0470	6	81	43	36	36	○				
4.8	3	External coolant	GD03-0480S	5	66	28	20	36	M5×0.5	○		
	5		GD05-0480S	5	82	44	35	36		○		
	3	Internal coolant	GD03C-0480S	5	66	28	20	36		○		
	5		GD05C-0480S	5	82	44	35	36		○		
	3	External coolant	GD03-0480	6	66	28	20	36		●		
	5		GD05-0480	6	82	44	35	36		●		
	3	Internal coolant	GD03C-0480	6	66	28	20	36		●		
	5		GD05C-0480	6	82	44	35	36		●		
8		GD08C-0480	6	95	57	48	36	○				
4.9	3	External coolant	GD03-0490S	5	66	28	20	36		○		
	5		GD05-0490S	5	82	44	35	36		○		
	3	Internal coolant	GD03C-0490S	5	66	28	20	36		○		
	5		GD05C-0490S	5	82	44	35	36		○		
	3	External coolant	GD03-0490	6	66	28	20	36		●		
	5		GD05-0490	6	82	44	35	36		●		
	3	Internal coolant	GD03C-0490	6	66	28	20	36		●		
	5		GD05C-0490	6	82	44	35	36		●		
8		GD08C-0490	6	95	57	48	36	○				

● Stock available ○ Make-to-order

Drilling tools

GD series



Drill diameter d ₁ (m7)	Drilling depth (l/d)	Cooling mode	Shank type	Type	Basic dimension(mm)					Suitable for thread		Grade
					Shank diameter	Overall length	Flute length	Recommended drilling depth	Shank length	cutting taps / tread milling cutters	forming taps	
					d ₂ (h ₆)	l ₁	l ₂	l ₃	l ₄			
5.0	3	External coolant	Straight shank	GD03-0500S	5	66	28	20	36	M6×1	NO.12-24UNC	○
	5			GD05-0500S	5	82	44	35	36			○
	3	Internal coolant		GD03C-0500S	5	66	28	20	36			○
	5			GD05C-0500S	5	82	44	35	36			○
	3	External coolant		GD03-0500	6	66	28	20	36			●
	5			GD05-0500	6	82	44	35	36			●
	3	Internal coolant		GD03C-0500	6	66	28	20	36			●
	5			GD05C-0500	6	82	44	35	36			●
8		GD08C-0500	6	95	57	48	36	○				
5.1	3	External coolant	GD03-0510	6	66	28	20	36	1/4-20UNC	NO.12-28UNF	●	
	5		GD05-0510	6	82	44	35	36			●	
	3	Internal coolant	GD03C-0510	6	66	28	20	36			●	
	5		GD05C-0510	6	82	44	35	36			●	
	8		GD08C-0510	6	95	57	48	36			○	
5.2	3	External coolant	GD03-0520	6	66	28	20	36			●	
	5		GD05-0520	6	82	44	35	36			●	
	3	Internal coolant	GD03C-0520	6	66	28	20	36			●	
	5		GD05C-0520	6	82	44	35	36			●	
	8		GD08C-0520	6	95	57	48	36			○	
5.25	3	External coolant	GD03-0525	6	66	28	20	36	M6×0.75		●	
	5		GD05-0525	6	82	44	35	36			●	
	3	Internal coolant	GD03C-0525	6	66	28	20	36			●	
	5		GD05C-0525	6	82	44	35	36			●	
5.3	3	External coolant	GD03-0530	6	66	28	20	36			●	
	5		GD05-0530	6	82	44	35	36			●	
	3	Internal coolant	GD03C-0530	6	66	28	20	36			●	
	5		GD05C-0530	6	82	44	35	36			●	
	8		GD08C-0530	6	95	57	48	36			○	
5.4	3	External coolant	GD03-0540	6	66	28	20	36			●	
	5		GD05-0540	6	82	44	35	36			●	
	3	Internal coolant	GD03C-0540	6	66	28	20	36			●	
	5		GD05C-0540	6	82	44	35	36			●	
	8		GD08C-0540	6	95	57	48	36			○	

Note: For drilling depth (l/d) of 8 ,namely GD08C series, tolerance of shank diameter is h₈.

● Stock available ○ Make-to-order

Drilling tools
GD series

➤ Applicable material table

⊙Very suitable ○Suitable

Grade	Workpiece material										
	Mild steel HB ≤ 180	Carbon steel, Alloy steel	Pre-hardened steel, Hardened steel			Stainless steel	Cast iron	Nodular cast iron	Aluminum alloy	Copper alloy	Heat resistant alloy
			~40HRC	~50HRC	~60HRC						
KDG3013	○	⊙	⊙			○	⊙	⊙			○

Code key
C6

Cutting parameters
C79-C80

Technical information
C87-C93

Non-standard customization tools
C94-C98



BORING TOOL / Drilling Tools

GD series

GD series General machining

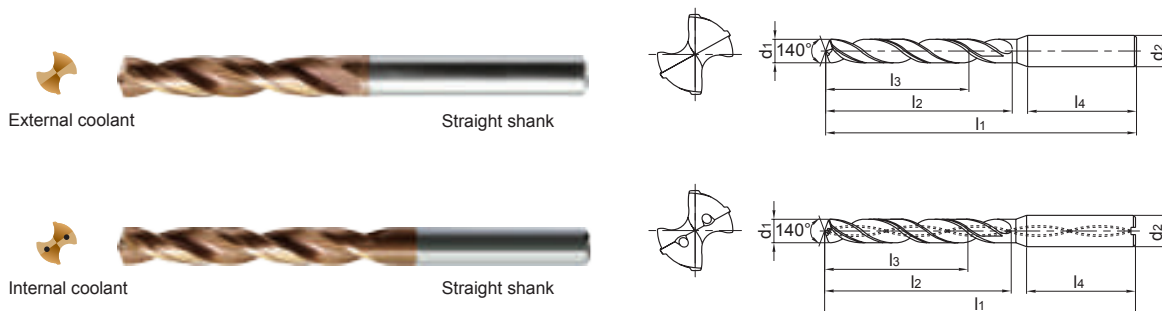

● Suitable for high efficiency drilling in a variety of materials e.g steel, stainless steel, cast iron.

Drill diameter d1(m7)	Drilling depth (l/d)	Cooling mode	Shank type	Type	Basic dimension(mm)					Suitable for thread		Grade
					Shank diameter d2(h6)	Overall length l1	Flute length l2	Recommended drilling depth l3	Shank length l4	cutting taps / tread milling cutters	forming taps	
5.5	3	External coolant	Straight shank	GD03-0550	6	66	28	20	36	1/4-28UNF		●
	5			GD05-0550	6	82	44	35	36			●
	3	GD03C-0550		6	66	28	20	36	●			
	5	GD05C-0550		6	82	44	35	36	●			
	8	GD08C-0550		6	95	57	48	36	○			
5.55	3	External coolant		GD03-0555	6	66	28	20	36			●
	5			GD05-0555	6	82	44	35	36			●
	3	GD03C-0555		6	66	28	20	36	●			
	5	GD05C-0555		6	82	44	35	36	●			
	8	GD08C-0555		6	95	57	48	36	○			
5.6	3	External coolant	GD03-0560	6	66	28	20	36	M6×1		●	
	5		GD05-0560	6	82	44	35	36			●	
	3	GD03C-0560	6	66	28	20	36	●				
	5	GD05C-0560	6	82	44	35	36	●				
	8	GD08C-0560	6	95	57	48	36	○				
5.7	3	External coolant	GD03-0570	6	66	28	20	36	M6×0.75		●	
	5		GD05-0570	6	82	44	35	36			●	
	3	GD03C-0570	6	66	28	20	36	●				
	5	GD05C-0570	6	82	44	35	36	●				
	8	GD08C-0570	6	95	57	48	36	○				
5.75	3	External coolant	GD03-0575	6	66	28	20	36	1/4-20UNC		●	
	5		GD05-0575	6	82	44	35	36			●	
	3	GD03C-0575	6	66	28	20	36	●				
	5	GD05C-0575	6	82	44	35	36	●				
	8	GD08C-0575	6	95	57	48	36	○				
5.8	3	External coolant	GD03-0580	6	66	28	20	36			●	
	5		GD05-0580	6	82	44	35	36			●	
	3	GD03C-0580	6	66	28	20	36	●				
	5	GD05C-0580	6	82	44	35	36	●				
	8	GD08C-0580	6	95	57	48	36	○				

● Stock available ○ Make-to-order

Drilling tools

GD series



Drill diameter d ₁ (m7)	Drilling depth (l/d)	Cooling mode	Shank type	Type	Basic dimension(mm)					Suitable for thread		Grade
					Shank diameter	Overall length	Flute length	Recommended drilling depth	Shank length	cutting taps / tread milling cutters	forming taps	
					d ₂ (h ₆)	l ₁	l ₂	l ₃	l ₄			
5.9	3	External coolant	Straight shank	GD03-0590	6	66	28	20	36	M7×1	1/4-28UNF	●
	5			GD05-0590	6	82	44	35	36			●
	3	Internal coolant		GD03C-0590	6	66	28	20	36			●
	5			GD05C-0590	6	82	44	35	36			●
	8			GD08C-0590	6	95	57	48	36			○
5.95	3	External coolant		GD03-0595	6	66	28	20	36			●
	5			GD05-0595	6	82	44	35	36			●
	3	Internal coolant		GD03C-0595	6	66	28	20	36			●
	5			GD05C-0595	6	82	44	35	36			●
6.0	3	External coolant		GD03-0600	6	66	28	20	36			●
	5		GD05-0600	6	82	44	35	36	●			
	3	Internal coolant	GD03C-0600	6	66	28	20	36	●			
	5		GD05C-0600	6	82	44	35	36	●			
	8		GD08C-0600	6	95	57	48	36	○			
6.1	3	External coolant	GD03-0610S	7	79	34	24	36	○			
	5		GD05-0610S	7	91	53	43	36	○			
	3	Internal coolant	GD03C-0610S	7	79	34	24	36	○			
	5		GD05C-0610S	7	91	53	43	36	○			
	3	External coolant	GD03-0610	8	79	34	24	36	●			
	5		GD05-0610	8	91	53	43	36	●			
	3	Internal coolant	GD03C-0610	8	79	34	24	36	●			
	5		GD05C-0610	8	91	53	43	36	●			
8	GD08C-0610	8	114	76	66	36	○					
6.2	3	External coolant	GD03-0620S	7	79	34	24	36	○			
	5		GD05-0620S	7	91	53	43	36	○			
	3	Internal coolant	GD03C-0620S	7	79	34	24	36	○			
	5		GD05C-0620S	7	91	53	43	36	○			
	3	External coolant	GD03-0620	8	79	34	24	36	●			
	5		GD05-0620	8	91	53	43	36	●			
	3	Internal coolant	GD03C-0620	8	79	34	24	36	●			
	5		GD05C-0620	8	91	53	43	36	●			
8	GD08C-0620	8	114	76	66	36	○					

Note: For drilling depth (l/d) of 8 ,namely GD08C series, tolerance of shank diameter is h₅. ● Stock available ○ Make-to-order

Drilling tools
GD series

➤ Applicable material table

⊙Very suitable ○Suitable

Grade	Workpiece material									
	Mild steel HB ≤ 180	Carbon steel, Alloy steel	Pre-hardened steel, Hardened steel			Stainless steel	Cast iron	Nodular cast iron	Aluminum alloy	Copper alloy
KDG3013	○	⊙	⊙			○	⊙	⊙		○





BORING TOOL / Drilling Tools

GD series

GD series General machining

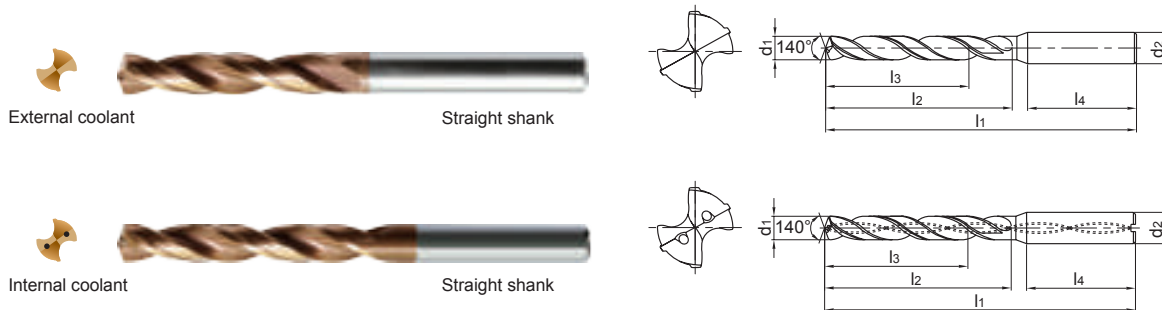

● Suitable for high efficiency drilling in a variety of materials e.g steel, stainless steel, cast iron.

Drill diameter d1(m7)	Drilling depth (l/d)	Cooling mode	Shank type	Type	Basic dimension(mm)					Suitable for thread		Grade
					Shank diameter d2(h6)	Overall length l1	Flute length l2	Recommended drilling depth l3	Shank length l4	cutting taps / tread milling cutters	forming taps	
6.3	3	External coolant	Straight shank	GD03-0630S	7	79	34	24	36			○
	5			GD05-0630S	7	91	53	43	36			○
	3	Internal coolant		GD03C-0630S	7	79	34	24	36			○
	5			GD05C-0630S	7	91	53	43	36			○
	3	External coolant		GD03-0630	8	79	34	24	36			●
	5			GD05-0630	8	91	53	43	36			●
	3	Internal coolant		GD03C-0630	8	79	34	24	36			●
	5			GD05C-0630	8	91	53	43	36			●
8		GD08C-0630	8	114	76	66	36			○		
6.4	3	External coolant	GD03-0640S	7	79	34	24	36			○	
	5		GD05-0640S	7	91	53	43	36			○	
	3	Internal coolant	GD03C-0640S	7	79	34	24	36			○	
	5		GD05C-0640S	7	91	53	43	36			○	
	3	External coolant	GD03-0640	8	79	34	24	36			●	
	5		GD05-0640	8	91	53	43	36			●	
	3	Internal coolant	GD03C-0640	8	79	34	24	36			●	
	5		GD05C-0640	8	91	53	43	36			●	
8		GD08C-0640	8	114	76	66	36			○		
6.5	3	External coolant	GD03-0650S	7	79	34	24	36			○	
	5		GD05-0650S	7	91	53	43	36			○	
	3	Internal coolant	GD03C-0650S	7	79	34	24	36			○	
	5		GD05C-0650S	7	91	53	43	36			○	
	3	External coolant	GD03-0650	8	79	34	24	36			●	
	5		GD05-0650	8	91	53	43	36			●	
	3	Internal coolant	GD03C-0650	8	79	34	24	36			●	
	5		GD05C-0650	8	91	53	43	36			●	
8		GD08C-0650	8	114	76	66	36			○		

● Stock available ○ Make-to-order

Drilling tools

GD series



Drill diameter d ₁ (m7)	Drilling depth (l/d)	Cooling mode	Shank type	Type	Basic dimension(mm)					Suitable for thread		Grade
					Shank diameter	Overall length	Flute length	Recommended drilling depth	Shank length	cutting taps / tread milling cutters	forming taps	
					d ₂ (h6)	l ₁	l ₂	l ₃	l ₄			
6.6	3	External coolant	Straight shank	GD03-0660S	7	79	34	24	36	5/16-18UNC	M7×1	○
	5			GD05-0660S	7	91	53	43	36			○
	3	Internal coolant		GD03C-0660S	7	79	34	24	36			○
	5			GD05C-0660S	7	91	53	43	36			○
	3	External coolant		GD03-0660	8	79	34	24	36			●
	5			GD05-0660	8	91	53	43	36			●
	3	Internal coolant		GD03C-0660	8	79	34	24	36			●
	5			GD05C-0660	8	91	53	43	36			●
8	GD08C-0660	8		114	76	66	36	○				
6.7	3	External coolant		GD03-0670S	7	79	34	24	36	M8×1.25		○
	5			GD05-0670S	7	91	53	43	36			○
	3	Internal coolant		GD03C-0670S	7	79	34	24	36			○
	5			GD05C-0670S	7	91	53	43	36			○
	3	External coolant		GD03-0670	8	79	34	24	36			●
	5			GD05-0670	8	91	53	43	36			●
	3	Internal coolant		GD03C-0670	8	79	34	24	36			●
	5		GD05C-0670	8	91	53	43	36	●			
8	GD08C-0670	8	114	76	66	36	○					
6.75	3	External coolant	GD03-0675S	7	79	34	24	36	M8×1.25		○	
	5		GD05-0675S	7	91	53	43	36			○	
	3	Internal coolant	GD03C-0675S	7	79	34	24	36			○	
	5		GD05C-0675S	7	91	53	43	36			○	
	3	External coolant	GD03-0675	8	79	34	24	36			●	
	5		GD05-0675	8	91	53	43	36			●	
	3	Internal coolant	GD03C-0675	8	79	34	24	36			●	
	5		GD05C-0675	8	91	53	43	36			●	
6.8	3	External coolant	GD03-0680S	7	79	34	24	36	M8×1.25		○	
	5		GD05-0680S	7	91	53	43	36			○	
	3	Internal coolant	GD03C-0680S	7	79	34	24	36			○	
	5		GD05C-0680S	7	91	53	43	36			○	
	3	External coolant	GD03-0680	8	79	34	24	36			●	
	5		GD05-0680	8	91	53	43	36			●	
	3	Internal coolant	GD03C-0680	8	79	34	24	36			●	
	5		GD05C-0680	8	91	53	43	36			●	
8	GD08C-0680	8	114	76	66	36	○					

Note: For drilling depth (l/d) of 8 ,namely GD08C series, tolerance of shank diameter is hs.

● Stock available ○ Make-to-order

Drilling tools
GD series

➤ Applicable material table

⊙Very suitable ○Suitable

Grade	Workpiece material										
	Mild steel HB ≤ 180	Carbon steel, Alloy steel	Pre-hardened steel, Hardened steel			Stainless steel	Cast iron	Nodular cast iron	Aluminum alloy	Copper alloy	Heat resistant alloy
			~40HRC	~50HRC	~60HRC						
KDG3013	○	⊙	⊙			○	⊙	⊙		○	

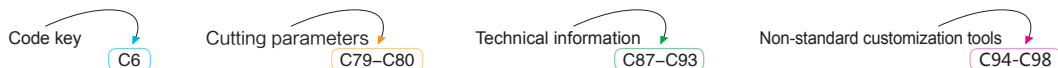



BORING TOOL / Drilling Tools

GD series

GD series General machining

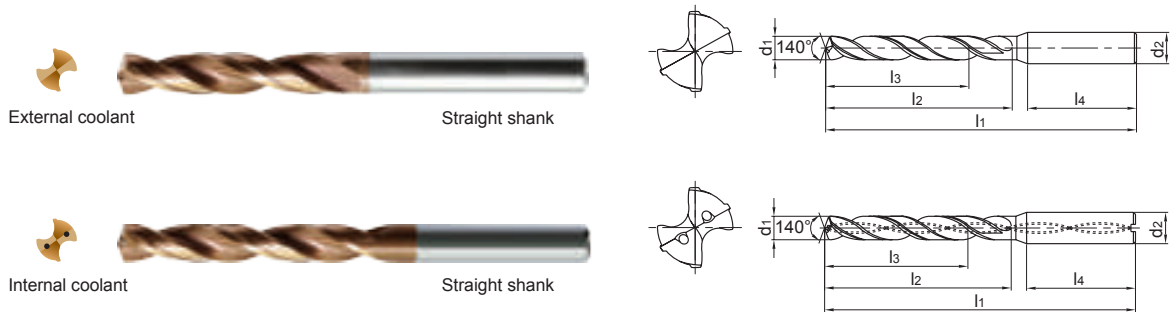

● Suitable for high efficiency drilling in a variety of materials e.g steel, stainless steel, cast iron.

Drill diameter d1(m7)	Drilling depth (l/d)	Cooling mode	Shank type	Type	Basic dimension(mm)					Suitable for thread		Grade
					Shank diameter d2(h6)	Overall length l1	Flute length l2	Recommended drilling depth l3	Shank length l4	cutting taps / tread milling cutters	forming taps	
6.9	3	External coolant	Straight shank	GD03-0690S	7	79	34	24	36	5/16-24UNF		○
	5			GD05-0690S	7	91	53	43	36			○
	3	Internal coolant		GD03C-0690S	7	79	34	24	36			○
	5			GD05C-0690S	7	91	53	43	36			○
	3	External coolant		GD03-0690	8	79	34	24	36			●
	5			GD05-0690	8	91	53	43	36			●
	3	Internal coolant		GD03C-0690	8	79	34	24	36			●
	5			GD05C-0690	8	91	53	43	36			●
8		GD08C-0690	8	114	76	66	36	○				
7.0	3	External coolant	GD03-0700S	7	79	34	24	36	M8×1		○	
	5		GD05-0700S	7	91	53	43	36			○	
	3	Internal coolant	GD03C-0700S	7	79	34	24	36			○	
	5		GD05C-0700S	7	91	53	43	36			○	
	3	External coolant	GD03-0700	8	79	34	24	36			●	
	5		GD05-0700	8	91	53	43	36			●	
	3	Internal coolant	GD03C-0700	8	79	34	24	36			●	
	5		GD05C-0700	8	91	53	43	36			●	
8		GD08C-0700	8	116	76	66	36	○				
7.1	3	External coolant	GD03-0710	8	79	41	29	36			●	
	5		GD05-0710	8	91	53	43	36			●	
	3	Internal coolant	GD03C-0710	8	79	41	29	36			●	
	5		GD05C-0710	8	91	53	43	36			●	
	8		GD08C-0710	8	116	76	66	36			○	
7.2	3	External coolant	GD03-0720	8	79	41	29	36			●	
	5		GD05-0720	8	91	53	43	36			●	
	3	Internal coolant	GD03C-0720	8	79	41	29	36			●	
	5		GD05C-0720	8	91	53	43	36			●	
	8		GD08C-0720	8	116	76	66	36			○	

● Stock available ○ Make-to-order

Drilling tools

GD series



Drill diameter d ₁ (m7)	Drilling depth (l/d)	Cooling mode	Shank type	Type	Basic dimension(mm)					Suitable for thread		Grade
					Shank diameter	Overall length	Flute length	Recommended drilling depth	Shank length	cutting taps / tread milling cutters	forming taps	
					d ₂ (h6)	l ₁	l ₂	l ₃	l ₄			
7.3	3	External coolant	Straight shank	GD03-0730	8	79	41	29	36	5/16-18UNC	●	
	5			GD05-0730	8	91	53	43	36		●	
	3	Internal coolant		GD03C-0730	8	79	41	29	36		●	
	5			GD05C-0730	8	91	53	43	36		●	
	8			GD08C-0730	8	116	76	66	36		○	
7.4	3	External coolant		GD03-0740	8	79	41	29	36		M8×1.25 5/16-24UNF	●
	5			GD05-0740	8	91	53	43	36			●
	3	Internal coolant		GD03C-0740	8	79	41	29	36			●
	5			GD05C-0740	8	91	53	43	36			●
	8			GD08C-0740	8	116	76	66	36			○
7.45	3	External coolant	GD03-0745	8	79	41	29	36	M8×1.25 5/16-24UNF	●		
	5		GD05-0745	8	91	53	43	36		●		
	3	Internal coolant	GD03C-0745	8	79	41	29	36		●		
	5		GD05C-0745	8	91	53	43	36		●		
7.5	3	External coolant	GD03-0750	8	79	41	29	36	M8×1	●		
	5		GD05-0750	8	91	53	43	36		●		
	3	Internal coolant	GD03C-0750	8	79	41	29	36		●		
	5		GD05C-0750	8	91	53	43	36		●		
	8		GD08C-0750	8	116	76	66	36		○		
7.6	3	External coolant	GD03-0760	8	79	41	29	36		M8×1	●	
	5		GD05-0760	8	91	53	43	36			●	
	3	Internal coolant	GD03C-0760	8	79	41	29	36			●	
	5		GD05C-0760	8	91	53	43	36			●	
7.7	3	External coolant	GD03-0770	8	79	41	29	36		M8×1	●	
	5		GD05-0770	8	91	53	43	36	●			
	3	Internal coolant	GD03C-0770	8	79	41	29	36	●			
	5		GD05C-0770	8	91	53	43	36	●			
	8		GD08C-0770	8	116	76	66	36	○			
7.8	3	External coolant	GD03-0780	8	79	41	29	36	M8×1		●	
	5		GD05-0780	8	91	53	43	36			●	
	3	Internal coolant	GD03C-0780	8	79	41	29	36			●	
	5		GD05C-0780	8	91	53	43	36			●	
	8		GD08C-0780	8	116	76	66	36			○	

Note: For drilling depth (l/d) of 8 ,namely GD08C series, tolerance of shank diameter is h₈.

● Stock available ○ Make-to-order

Drilling tools

GD series

➤ Applicable material table

● Very suitable ○ Suitable

Grade	Workpiece material									
	Mild steel HB ≤ 180	Carbon steel, Alloy steel	Pre-hardened steel, Hardened steel			Stainless steel	Cast iron	Nodular cast iron	Aluminum alloy	Copper alloy
KDG3013	○	●	●			○	●	●		○

Code key
C6

Cutting parameters
C79-C80

Technical information
C87-C93

Non-standard customization tools
C94-C98



BORING TOOL / Drilling Tools

GD series

GD series General machining

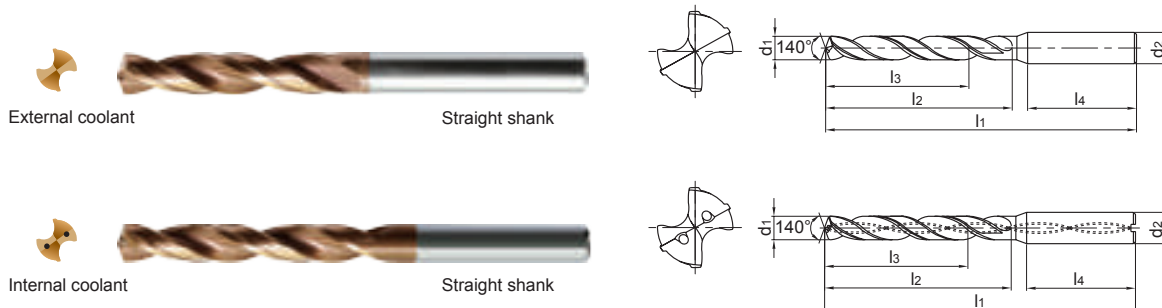

● Suitable for high efficiency drilling in a variety of materials e.g steel, stainless steel, cast iron.

Drill diameter d1(m7)	Drilling depth (l/d)	Cooling mode	Shank type	Type	Basic dimension(mm)					Suitable for thread		Grade	
					Shank diameter d2(h6)	Overall length l1	Flute length l2	Recommended drilling depth l3	Shank length l4	cutting taps / tread milling cutters	forming taps		
													KDG3013
7.9	3	External coolant	Straight shank	GD03-0790	8	79	41	29	36			●	
	5			GD05-0790	8	91	53	43	36			●	
	3	Internal coolant		GD03C-0790	8	79	41	29	36			●	
	5			GD05C-0790	8	91	53	43	36			●	
	8			GD08C-0790	8	116	76	66	36			○	
8.0	3	External coolant		GD03-0800	8	79	41	29	36	3/8-16UNC			●
	5			GD05-0800	8	91	53	43	36				●
	3	Internal coolant		GD03C-0800	8	79	41	29	36				●
	5			GD05C-0800	8	91	53	43	36				●
	8			GD08C-0800	8	116	76	66	36				○
8.1	3	External coolant	GD03-0810S	9	89	47	35	40			○		
	5		GD05-0810S	9	103	61	49	40			○		
	3	Internal coolant	GD03C-0810S	9	89	47	35	40			○		
	5		GD05C-0810S	9	103	61	49	40			○		
	3		External coolant	GD03-0810	10	89	47	35	40			●	
	5	GD05-0810		10	103	61	49	40			●		
	3	Internal coolant		GD03C-0810	10	89	47	35	40			●	
	5		GD05C-0810	10	103	61	49	40			●		
8.2	3	External coolant	GD03-0820S	9	89	47	35	40			○		
	5		GD05-0820S	9	103	61	49	40			○		
	3	Internal coolant	GD03C-0820S	9	89	47	35	40			○		
	5		GD05C-0820S	9	103	61	49	40			○		
	3	External coolant	GD03-0820	10	89	47	35	40			●		
	5		GD05-0820	10	103	61	49	40			●		
	3		Internal coolant	GD03C-0820	10	89	47	35	40			●	
	5	GD05C-0820		10	103	61	49	40			●		
	8	GD08C-0820		10	142	95	83	40			○		

● Stock available ○ Make-to-order

Drilling tools

GD series



Drill diameter d ₁ (m7)	Drilling depth (l/d)	Cooling mode	Shank type	Type	Basic dimension(mm)					Suitable for thread		Grade		
					Shank diameter	Overall length	Flute length	Recommended drilling depth	Shank length	cutting taps / tread milling cutters	forming taps			
					d ₂ (h ₆)	l ₁	l ₂	l ₃	l ₄					
8.3	3	External coolant	Straight shank	GD03-0830S	9	89	47	35	40	M10×1.5 3/8-24UNF		○		
	5			GD05-0830S	9	103	61	49	40			○		
	3	Internal coolant		GD03C-0830S	9	89	47	35	40			○		
	5			GD05C-0830S	9	103	61	49	40			○		
	3	External coolant		GD03-0830	10	89	47	35	40			●		
	5			GD05-0830	10	103	61	49	40			●		
	3	Internal coolant		GD03C-0830	10	89	47	35	40			●		
	5			GD05C-0830	10	103	61	49	40			●		
8		GD08C-0830		10	142	95	83	40	○					
8.4	3	External coolant		GD03-0840S	9	89	47	35	40					○
	5			GD05-0840S	9	103	61	49	40					○
	3	Internal coolant		GD03C-0840S	9	89	47	35	40					○
	5			GD05C-0840S	9	103	61	49	40					○
	3	External coolant		GD03-0840	10	89	47	35	40					●
	5			GD05-0840	10	103	61	49	40					●
	3	Internal coolant		GD03C-0840	10	89	47	35	40					●
	5		GD05C-0840	10	103	61	49	40	●					
8		GD08C-0840	10	142	95	83	40	○						
8.5	3	External coolant	GD03-0850S	9	89	47	35	40			○			
	5		GD05-0850S	9	103	61	49	40			○			
	3	Internal coolant	GD03C-0850S	9	89	47	35	40			○			
	5		GD05C-0850S	9	103	61	49	40			○			
	3	External coolant	GD03-0850	10	89	47	35	40			●			
	5		GD05-0850	10	103	61	49	40			●			
	3	Internal coolant	GD03C-0850	10	89	47	35	40			●			
	5		GD05C-0850	10	103	61	49	40			●			
8		GD08C-0850	10	142	95	83	40	○						
8.6	3	External coolant	GD03-0860S	9	89	47	35	40			○			
	5		GD05-0860S	9	103	61	49	40			○			
	3	Internal coolant	GD03C-0860S	9	89	47	35	40			○			
	5		GD05C-0860S	9	103	61	49	40			○			
	3	External coolant	GD03-0860	10	89	47	35	40			●			
	5		GD05-0860	10	103	61	49	40			●			
	3	Internal coolant	GD03C-0860	10	89	47	35	40			●			
	5		GD05C-0860	10	103	61	49	40			●			
8		GD08C-0860	10	142	95	83	40	○						

Note: For drilling depth (l/d) of 8 ,namely GD08C series, tolerance of shank diameter is h₈. ● Stock available ○ Make-to-order

➤ Applicable material table

● Very suitable ○ Suitable

Grade	Workpiece material										
	Mild steel HB ≤ 180	Carbon steel, Alloy steel	Pre-hardened steel, Hardened steel			Stainless steel	Cast iron	Nodular cast iron	Aluminum alloy	Copper alloy	Heat resistant alloy
			~40HRC	~50HRC	~60HRC						
KDG3013	○	●	●			○	●	●		○	

Code key
C6

Cutting parameters
C79-C80

Technical information
C87-C93

Non-standard customization tools
C94-C98

Drilling tools

GD series



BORING TOOL / Drilling Tools

GD series

GD series General machining

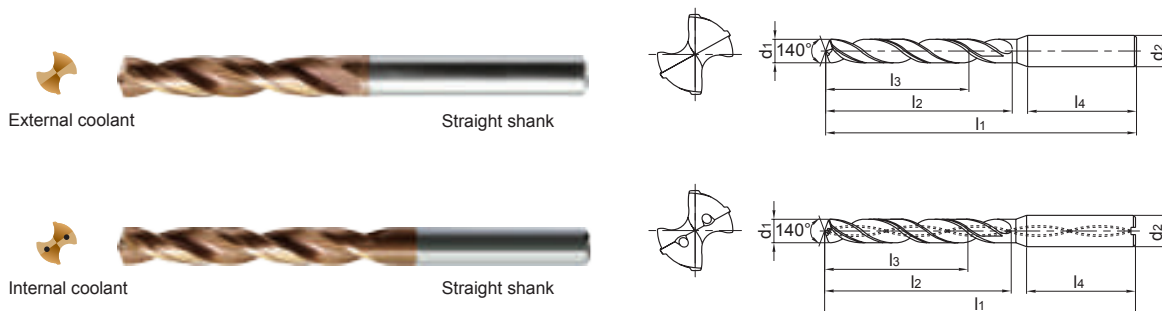

● Suitable for high efficiency drilling in a variety of materials e.g steel, stainless steel, cast iron.

Drill diameter d1(m7)	Drilling depth (l/d)	Cooling mode	Shank type	Type	Basic dimension(mm)					Suitable for thread		Grade
					Shank diameter d2(h6)	Overall length l1	Flute length l2	Recommended drilling depth l3	Shank length l4	cutting taps / tread milling cutters	forming taps	
8.7	3	External coolant	Straight shank	GD03-0870S	9	89	47	35	40	M10×1.25		○
	5			GD05-0870S	9	103	61	49	40			○
	3	Internal coolant		GD03C-0870S	9	89	47	35	40			○
	5			GD05C-0870S	9	103	61	49	40			○
	3	External coolant		GD03-0870	10	89	47	35	40			●
	5			GD05-0870	10	103	61	49	40			●
	3	Internal coolant		GD03C-0870	10	89	47	35	40			●
	5			GD05C-0870	10	103	61	49	40			●
8		GD08C-0870	10	142	95	83	40	○				
8.75	3	External coolant	GD03-0875S	9	89	47	35	40	M10×1.25		○	
	5		GD05-0875S	9	103	61	49	40			○	
	3	Internal coolant	GD03C-0875S	9	89	47	35	40			○	
	5		GD05C-0875S	9	103	61	49	40			○	
	3	External coolant	GD03-0875	10	89	47	35	40			●	
	5		GD05-0875	10	103	61	49	40			●	
	3	Internal coolant	GD03C-0875	10	89	47	35	40			●	
	5		GD05C-0875	10	103	61	49	40			●	
8.8	3	External coolant	GD03-0880S	9	89	47	35	40	3/8-16UNC		○	
	5		GD05-0880S	9	103	61	49	40			○	
	3	Internal coolant	GD03C-0880S	9	89	47	35	40			○	
	5		GD05C-0880S	9	103	61	49	40			○	
	3	External coolant	GD03-0880	10	89	47	35	40			●	
	5		GD05-0880	10	103	61	49	40			●	
	3	Internal coolant	GD03C-0880	10	89	47	35	40			●	
	5		GD05C-0880	10	103	61	49	40			●	
	8		GD08C-0880	10	142	95	83	40			○	

● Stock available ○ Make-to-order

Drilling tools

GD series



Drill diameter d ₁ (m7)	Drilling depth (l/d)	Cooling mode	Shank type	Type	Basic dimension(mm)					Suitable for thread		Grade
					Shank diameter	Overall length	Flute length	Recommended drilling depth	Shank length	cutting taps / tread milling cutters	forming taps	
					d ₂ (h ₆)	l ₁	l ₂	l ₃	l ₄			
8.9	3	External coolant	Straight shank	GD03-0890S	9	89	47	35	40	M10×1	3/8-24UNF	○
	5			GD05-0890S	9	103	61	49	40			○
	3	Internal coolant		GD03C-0890S	9	89	47	35	40			○
	5			GD05C-0890S	9	103	61	49	40			○
	3	External coolant		GD03-0890	10	89	47	35	40			●
	5			GD05-0890	10	103	61	49	40			●
	3	Internal coolant		GD03C-0890	10	89	47	35	40			●
	5			GD05C-0890	10	103	61	49	40			●
8		GD08C-0890	10	142	95	83	40	○				
9.0	3	External coolant	GD03-0900S	9	89	47	35	40	M10×1	3/8-24UNF	○	
	5		GD05-0900S	9	103	61	49	40			○	
	3	Internal coolant	GD03C-0900S	9	89	47	35	40			○	
	5		GD05C-0900S	9	103	61	49	40			○	
	3	External coolant	GD03-0900	10	89	47	35	40			●	
	5		GD05-0900	10	103	61	49	40			●	
	3	Internal coolant	GD03C-0900	10	89	47	35	40			●	
	5		GD05C-0900	10	103	61	49	40			●	
8		GD08C-0900	10	142	95	83	40	○				
9.1	3	External coolant	GD03-0910	10	89	47	35	40	M10×1	3/8-24UNF	●	
	5		GD05-0910	10	103	61	49	40			●	
	3	Internal coolant	GD03C-0910	10	89	47	35	40			●	
	5		GD05C-0910	10	103	61	49	40			●	
	8		GD08C-0910	10	142	95	83	40			○	
9.2	3	External coolant	GD03-0920	10	89	47	35	40	M10×1	3/8-24UNF	●	
	5		GD05-0920	10	103	61	49	40			●	
	3	Internal coolant	GD03C-0920	10	89	47	35	40			●	
	5		GD05C-0920	10	103	61	49	40			●	
	8		GD08C-0920	10	142	95	83	40			○	
9.3	3	External coolant	GD03-0930	10	89	47	35	40	M10×1	3/8-24UNF	●	
	5		GD05-0930	10	103	61	49	40			●	
	3	Internal coolant	GD03C-0930	10	89	47	35	40			●	
	5		GD05C-0930	10	103	61	49	40			●	
	8		GD08C-0930	10	142	95	83	40			○	

Note: For drilling depth (l/d) of 8 ,namely GD08C series, tolerance of shank diameter is h₈.

● Stock available ○ Make-to-order

Drilling tools

GD series

➤ Applicable material table

⊙Very suitable ○Suitable

Grade	Workpiece material									
	Mild steel HB ≤ 180	Carbon steel, Alloy steel	Pre-hardened steel, Hardened steel			Stainless steel	Cast iron	Nodular cast iron	Aluminum alloy	Copper alloy
KDG3013	○	⊙	⊙			○	⊙	⊙		○

Code key

C6

Cutting parameters

C79-C80

Technical information

C87-C93

Non-standard customization tools

C94-C98



BORING TOOL / Drilling Tools

GD series

GD series General machining

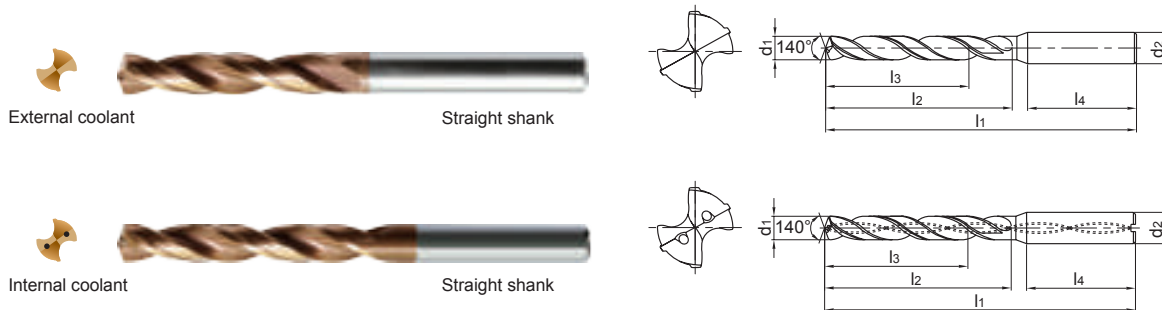

● Suitable for high efficiency drilling in a variety of materials e.g steel, stainless steel, cast iron.

Drill diameter d1(m7)	Drilling depth (l/d)	Cooling mode	Shank type	Type	Basic dimension(mm)					Suitable for thread		Grade		
					Shank diameter d2(h6)	Overall length l1	Flute length l2	Recommended drilling depth l3	Shank length l4	cutting taps / tread milling cutters	forming taps			
													KDG3013	
9.35	3	External coolant	Straight shank	GD03-0935	10	89	47	35	40	7/16-14UNC	M10×1.5	●		
	5			GD05-0935	10	103	61	49	40			●		
	3	Internal coolant		GD03C-0935	10	89	47	35	40			●		
	5			GD05C-0935	10	103	61	49	40			●		
9.4	3	External coolant		GD03-0940	10	89	47	35	40			7/16-14UNC	M10×1.25	●
	5			GD05-0940	10	103	61	49	40					●
	3	Internal coolant		GD03C-0940	10	89	47	35	40					●
	5			GD05C-0940	10	103	61	49	40					●
9.45	8		GD08C-0940	10	142	95	83	40		○				
	3	External coolant	GD03-0945	10	89	47	35	40	M10×1.25	●				
	5		GD05-0945	10	103	61	49	40		●				
	3	Internal coolant	GD03C-0945	10	89	47	35	40		●				
5	GD05C-0945		10	103	61	49	40	●						
9.5	3	External coolant	GD03-0950	10	89	47	35	40		M10×1	●			
	5		GD05-0950	10	103	61	49	40			●			
	3	Internal coolant	GD03C-0950	10	89	47	35	40			●			
	5		GD05C-0950	10	103	61	49	40			●			
9.6	8		GD08C-0950	10	142	95	83	40			○			
	3	External coolant	GD03-0960	10	89	47	35	40	M10×1		●			
	5		GD05-0960	10	103	61	49	40			●			
	3	Internal coolant	GD03C-0960	10	89	47	35	40			●			
5	GD05C-0960		10	103	61	49	40	●						
9.7	8		GD08C-0960	10	142	95	83	40			○			
	3	External coolant	GD03-0970	10	89	47	35	40		M10×1	●			
	5		GD05-0970	10	103	61	49	40			●			
	3	Internal coolant	GD03C-0970	10	89	47	35	40			●			
5	GD05C-0970		10	103	61	49	40	●						
9.7	8		GD08C-0970	10	142	95	83	40			○			

● Stock available ○ Make-to-order

Drilling tools

GD series



Drill diameter d ₁ (mm)	Drilling depth (l/d)	Cooling mode	Shank type	Type	Basic dimension(mm)					Suitable for thread		Grade		
					Shank diameter	Overall length	Flute length	Recommended drilling depth	Shank length	cutting taps / tread milling cutters	forming taps			
					d ₂ (h ₆)	l ₁	l ₂	l ₃	l ₄					
9.8	3	External coolant	Straight shank	GD03-0980	10	89	47	35	40	7/16-20UNF		●		
	5			GD05-0980	10	103	61	49	40			●		
	3	GD03C-0980		10	89	47	35	40	●					
	5	GD05C-0980		10	103	61	49	40	●					
	8	GD08C-0980		10	142	95	83	40	○					
9.9	3	External coolant		GD03-0990	10	89	47	35	40			7/16-20UNF		●
	5			GD05-0990	10	103	61	49	40					●
	3	GD03C-0990		10	89	47	35	40	●					
	5	GD05C-0990		10	103	61	49	40	●					
	8	GD08C-0990		10	142	95	83	40	○					
10.0	3	External coolant	GD03-1000	10	89	47	35	40	7/16-20UNF		●			
	5		GD05-1000	10	103	61	49	40			●			
	3	GD03C-1000	10	89	47	35	40	●						
	5	GD05C-1000	10	103	61	49	40	●						
10.1	8	Internal coolant	GD08C-1000	10	142	95	83	40			7/16-20UNF			
	3		GD03-1010S	11	102	55	40	45				○		
	5	GD05-1010S	11	118	71	56	45	○						
	3	GD03C-1010S	11	102	55	40	45	○						
	5	GD05C-1010S	11	118	71	56	45	○						
	3	External coolant	GD03-1010	12	102	55	40	45				7/16-20UNF		
	5		GD05-1010	12	118	71	56	45	●					
	3	GD03C-1010	12	102	55	40	45	●						
5	GD05C-1010	12	118	71	56	45	●							
8	GD08C-1010	12	162	114	99	45	○							
10.2	3	External coolant	GD03-1020S	11	102	55	40	45	7/16-20UNF		○			
	5		GD05-1020S	11	118	71	56	45			○			
	3	GD03C-1020S	11	102	55	40	45	○						
	5	GD05C-1020S	11	118	71	56	45	○						
	3	External coolant	GD03-1020	12	102	55	40	45			7/16-20UNF			
	5		GD05-1020	12	118	71	56	45				●		
	3	GD03C-1020	12	102	55	40	45	●						
	5	GD05C-1020	12	118	71	56	45	●						
8	GD08C-1020	12	162	114	99	45	○							

Note: For drilling depth (l/d) of 8 ,namely GD08C series, tolerance of shank diameter is h₅.

● Stock available ○ Make-to-order

Drilling tools

GD series

➤ Applicable material table

⊙Very suitable ○Suitable

Grade	Workpiece material									
	Mild steel HB ≤ 180	Carbon steel, Alloy steel	Pre-hardened steel, Hardened steel			Stainless steel	Cast iron	Nodular cast iron	Aluminum alloy	Copper alloy
KDG3013	○	⊙	⊙			○	⊙	⊙		○

Code key
C6

Cutting parameters
C79-C80

Technical information
C87-C93

Non-standard customization tools
C94-C98



BORING TOOL / Drilling Tools

GD series

GD series General machining

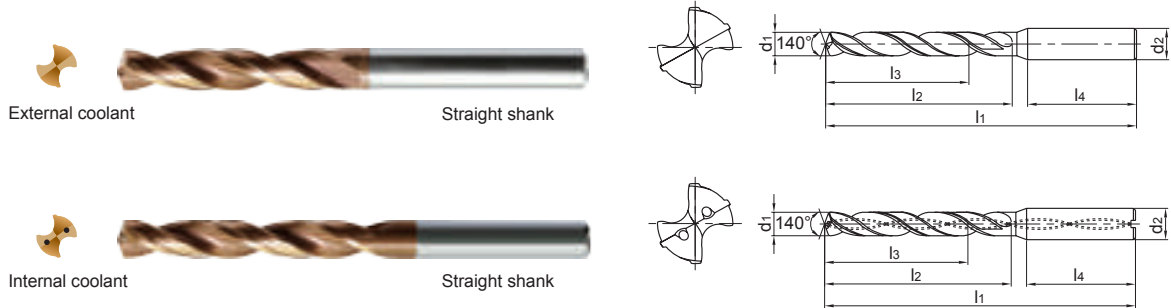

● Suitable for high efficiency drilling in a variety of materials e.g steel, stainless steel, cast iron.

Drill diameter d1(m7)	Drilling depth (l/d)	Cooling mode	Shank type	Type	Basic dimension(mm)					Suitable for thread		Grade
					Shank diameter d2(h6)	Overall length l1	Flute length l2	Recommended drilling depth l3	Shank length l4	cutting taps / tread milling cutters	forming taps	
10.25	3	External coolant	Straight shank	GD03-1025S	11	102	55	40	45	M12x1.75		○
	5			GD05-1025S	11	118	71	56	45		○	
	3	Internal coolant		GD03C-1025S	11	102	55	40	45		○	
	5			GD05C-1025S	11	118	71	56	45		○	
	3	External coolant		GD03-1025	12	102	55	40	45		●	
	5			GD05-1025	12	118	71	56	45		●	
	3	Internal coolant		GD03C-1025	12	102	55	40	45		●	
	5			GD05C-1025	12	118	71	56	45		●	
10.3	3	External coolant	GD03-1030S	11	102	55	40	45	7/16-14UNC	○		
	5		GD05-1030S	11	118	71	56	45		○		
	3	Internal coolant	GD03C-1030S	11	102	55	40	45		○		
	5		GD05C-1030S	11	118	71	56	45		○		
	3	External coolant	GD03-1030	12	102	55	40	45		●		
	5		GD05-1030	12	118	71	56	45		●		
	3	Internal coolant	GD03C-1030	12	102	55	40	45		●		
	5		GD05C-1030	12	118	71	56	45		●		
10.4	3	External coolant	GD03-1040S	11	102	55	40	45		○		
	5		GD05-1040S	11	118	71	56	45		○		
	3	Internal coolant	GD03C-1040S	11	102	55	40	45		○		
	5		GD05C-1040S	11	118	71	56	45		○		
	3	External coolant	GD03-1040	12	102	55	40	45		●		
	5		GD05-1040	12	118	71	56	45		●		
	3	Internal coolant	GD03C-1040	12	102	55	40	45		●		
	5		GD05C-1040	12	118	71	56	45		●		
8		GD08C-1040	12	162	114	99	45	○				

● Stock available ○ Make-to-order

Drilling tools

GD series



Drill diameter d ₁ (mm)	Drilling depth (l/d)	Cooling mode	Shank type	Type	Basic dimension(mm)					Suitable for thread		Grade
					Shank diameter	Overall length	Flute length	Recommended drilling depth	Shank length	cutting taps / tread milling cutters	forming taps	
					d ₂ (h ₆)	l ₁	l ₂	l ₃	l ₄			
10.5	3	External coolant	Straight shank	GD03-1050S	11	102	55	40	45	M12×1.5	7/16-20UNF	○
	5			GD05-1050S	11	118	71	56	45			○
	3	Internal coolant		GD03C-1050S	11	102	55	40	45			○
	5			GD05C-1050S	11	118	71	56	45			○
	3	External coolant		GD03-1050	12	102	55	40	45			●
	5			GD05-1050	12	118	71	56	45			●
	3	Internal coolant		GD03C-1050	12	102	55	40	45			●
	5			GD05C-1050	12	118	71	56	45			●
8		GD08C-1050	12	162	114	99	45	○				
10.6	3	External coolant	GD03-1060S	11	102	55	40	45	M12×1.25		○	
	5		GD05-1060S	11	118	71	56	45			○	
	3	Internal coolant	GD03C-1060S	11	102	55	40	45			○	
	5		GD05C-1060S	11	118	71	56	45			○	
	3	External coolant	GD03-1060	12	102	55	40	45			●	
	5		GD05-1060	12	118	71	56	45			●	
	3	Internal coolant	GD03C-1060	12	102	55	40	45			●	
	5		GD05C-1060	12	118	71	56	45			●	
8		GD08C-1060	12	162	114	99	45	○				
10.7	3	External coolant	GD03-1070S	11	102	55	40	45	M12×1.25		○	
	5		GD05-1070S	11	118	71	56	45			○	
	3	Internal coolant	GD03C-1070S	11	102	55	40	45			○	
	5		GD05C-1070S	11	118	71	56	45			○	
	3	External coolant	GD03-1070	12	102	55	40	45			●	
	5		GD05-1070	12	118	71	56	45			●	
	3	Internal coolant	GD03C-1070	12	102	55	40	45			●	
	5		GD05C-1070	12	118	71	56	45			●	
8		GD08C-1070	12	162	114	99	45	○				
10.75	3	External coolant	GD03-1075S	11	102	55	40	45	M12×1.25		○	
	5		GD05-1075S	11	118	71	56	45			○	
	3	Internal coolant	GD03C-1075S	11	102	55	40	45			○	
	5		GD05C-1075S	11	118	71	56	45			○	
	3	External coolant	GD03-1075	12	102	55	40	45			●	
	5		GD05-1075	12	118	71	56	45			●	
	3	Internal coolant	GD03C-1075	12	102	55	40	45			●	
	5		GD05C-1075	12	118	71	56	45			●	

Note: For drilling depth (l/d) of 8 ,namely GD08C series, tolerance of shank diameter is hs.

● Stock available ○ Make-to-order

Drilling tools

GD series

➤ Applicable material table

⊙Very suitable ○Suitable

Grade	Workpiece material										
	Mild steel HB ≤ 180	Carbon steel, Alloy steel	Pre-hardened steel, Hardened steel			Stainless steel	Cast iron	Nodular cast iron	Aluminum alloy	Copper alloy	Heat resistant alloy
			~40HRC	~50HRC	~60HRC						
KDG3013	○	⊙	⊙			○	⊙	⊙			○

Code key

C6

Cutting parameters
C79-C80

Technical information
C87-C93

Non-standard customization tools
C94-C98



BORING TOOL / Drilling Tools

GD series

GD series General machining

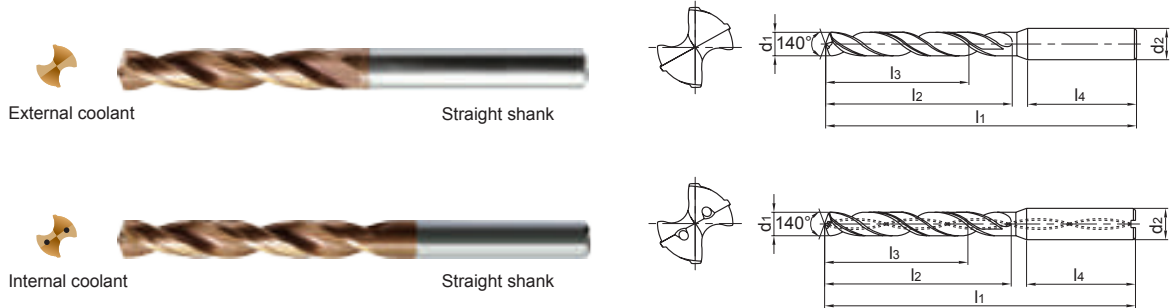

● Suitable for high efficiency drilling in a variety of materials e.g steel, stainless steel, cast iron.

Drill diameter d1(m7)	Drilling depth (l/d)	Cooling mode	Shank type	Type	Basic dimension(mm)					Suitable for thread		Grade
					Shank diameter d2(h6)	Overall length l1	Flute length l2	Recommended drilling depth l3	Shank length l4	cutting taps / tread milling cutters	forming taps	
10.8	3	External coolant	Straight shank	GD03-1080S	11	102	55	40	45	1/2-13UNC		○
	5			GD05-1080S	11	118	71	56	45		○	
	3	Internal coolant		GD03C-1080S	11	102	55	40	45		○	
	5			GD05C-1080S	11	118	71	56	45		○	
	3	External coolant		GD03-1080	12	102	55	40	45		●	
	5			GD05-1080	12	118	71	56	45		●	
	3	Internal coolant		GD03C-1080	12	102	55	40	45		●	
	5			GD05C-1080	12	118	71	56	45		●	
10.9	8		GD08C-1080	12	162	114	99	45		○		
	3	External coolant	GD03-1090S	11	102	55	40	45		○		
	5		GD05-1090S	11	118	71	56	45		○		
	3	Internal coolant	GD03C-1090S	11	102	55	40	45		○		
	5		GD05C-1090S	11	118	71	56	45		○		
	3	External coolant	GD03-1090	12	102	55	40	45		●		
	5		GD05-1090	12	118	71	56	45		●		
	3	Internal coolant	GD03C-1090	12	102	55	40	45		●		
5	GD05C-1090		12	118	71	56	45		●			
11.0	8		GD08C-1090	12	162	114	99	45		○		
	3	External coolant	GD03-1100S	11	102	55	40	45		○		
	5		GD05-1100S	11	118	71	56	45		○		
	3	Internal coolant	GD03C-1100S	11	102	55	40	45		○		
	5		GD05C-1100S	11	118	71	56	45		○		
	3	External coolant	GD03-1100	12	102	55	40	45		●		
	5		GD05-1100	12	118	71	56	45		●		
	3	Internal coolant	GD03C-1100	12	102	55	40	45		●		
5	GD05C-1100		12	118	71	56	45		●			
8		GD08C-1100	12	162	114	99	45		○			

● Stock available ○ Make-to-order

Drilling tools

GD series



Drill diameter d ₁ (mm)	Drilling depth (l/d)	Cooling mode	Shank type	Type	Basic dimension(mm)					Suitable for thread		Grade		
					Shank diameter	Overall length	Flute length	Recommended drilling depth	Shank length	cutting taps / tread milling cutters	forming taps			
					d ₂ (h ₆)	l ₁	l ₂	l ₃	l ₄					
11.1	3	External coolant	Straight shank	GD03-1110	12	102	55	40	45			●		
	5			GD05-1110	12	118	71	56	45			●		
	3	Internal coolant		GD03C-1110	12	102	55	40	45			●		
	5			GD05C-1110	12	118	71	56	45			●		
	8			GD08C-1110	12	162	114	99	45			○		
11.2	3	External coolant		GD03-1120	12	102	55	40	45					●
	5			GD05-1120	12	118	71	56	45					●
	3	Internal coolant		GD03C-1120	12	102	55	40	45					●
	5			GD05C-1120	12	118	71	56	45					●
	8			GD08C-1120	12	162	114	99	45					○
11.25	3	External coolant	GD03-1125	12	102	55	40	45	M12×1.75		●			
	5		GD05-1125	12	118	71	56	45			●			
	3	Internal coolant	GD03C-1125	12	102	55	40	45			●			
	5		GD05C-1125	12	118	71	56	45			●			
11.3	3	External coolant	GD03-1130	12	102	55	40	45						
	5		GD05-1130	12	118	71	56	45				●		
	3	Internal coolant	GD03C-1130	12	102	55	40	45				●		
	5		GD05C-1130	12	118	71	56	45				●		
	8		GD08C-1130	12	162	114	99	45	○					
11.35	3	External coolant	GD03-1135	12	102	55	40	45	M12×1.5			●		
	5		GD05-1135	12	118	71	56	45				●		
	3	Internal coolant	GD03C-1135	12	102	55	40	45				●		
	5		GD05C-1135	12	118	71	56	45				●		
11.4	3	External coolant	GD03-1140	12	102	55	40	45						
	5		GD05-1140	12	118	71	56	45			●			
	3	Internal coolant	GD03C-1140	12	102	55	40	45			●			
	5		GD05C-1140	12	118	71	56	45			●			
	8		GD08C-1140	12	162	114	99	45	○					
11.45	3	External coolant	GD03-1145	12	102	55	40	45	M12×1.25		●			
	5		GD05-1145	12	118	71	56	45			●			
	3	Internal coolant	GD03C-1145	12	102	55	40	45			●			
	5		GD05C-1145	12	118	71	56	45			●			

Note: For drilling depth (l/d) of 8 ,namely GD08C series, tolerance of shank diameter is h₅.

● Stock available ○ Make-to-order

Drilling tools
GD series

➤ Applicable material table

⊙Very suitable ○Suitable

Grade	Workpiece material										
	Mild steel HB ≤ 180	Carbon steel, Alloy steel	Pre-hardened steel, Hardened steel			Stainless steel	Cast iron	Nodular cast iron	Aluminum alloy	Copper alloy	Heat resistant alloy
			~40HRC	~50HRC	~60HRC						
KDG3013	○	⊙	⊙			○	⊙	⊙			○

Code key

C6

Cutting parameters
C79-C80

Technical information
C87-C93

Non-standard customization tools
C94-C98



BORING TOOL / Drilling Tools

GD series

GD series General machining

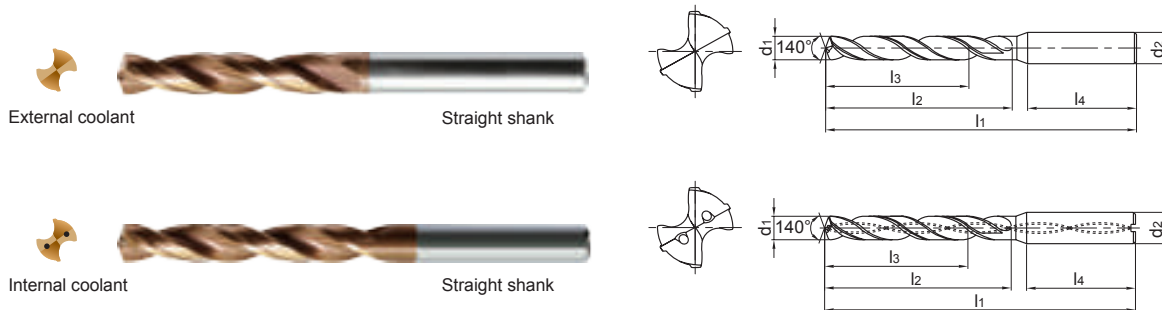

● Suitable for high efficiency drilling in a variety of materials e.g steel, stainless steel, cast iron.

Drill diameter d1(m7)	Drilling depth (l/d)	Cooling mode	Shank type	Type	Basic dimension(mm)					Suitable for thread		Grade
					Shank diameter d2(h6)	Overall length l1	Flute length l2	Recommended drilling depth l3	Shank length l4	cutting taps / tread milling cutters	forming taps	
11.5	3	External coolant	Straight shank	GD03-1150	12	102	55	40	45	1/2-20UNF		●
	5			GD05-1150	12	118	71	56	45			●
	3	GD03C-1150		12	102	55	40	45	●			
	5	GD05C-1150		12	118	71	56	45	●			
	8	GD08C-1150		12	162	114	99	45	○			
11.6	3	External coolant		GD03-1160	12	102	55	40	45			●
	5			GD05-1160	12	118	71	56	45			●
	3	GD03C-1160		12	102	55	40	45	●			
	5	GD05C-1160		12	118	71	56	45	●			
	8	GD08C-1160		12	162	114	99	45	○			
11.7	3	External coolant	GD03-1170	12	102	55	40	45			●	
	5		GD05-1170	12	118	71	56	45			●	
	3	GD03C-1170	12	102	55	40	45	●				
	5	GD05C-1170	12	118	71	56	45	●				
	8	GD08C-1170	12	162	114	99	45	○				
11.8	3	External coolant	GD03-1180	12	102	55	40	45	1/2-13UNC		●	
	5		GD05-1180	12	118	71	56	45			●	
	3	GD03C-1180	12	102	55	40	45	●				
	5	GD05C-1180	12	118	71	56	45	●				
	8	GD08C-1180	12	162	114	99	45	○				
11.9	3	External coolant	GD03-1190	12	102	55	40	45			●	
	5		GD05-1190	12	118	71	56	45			●	
	3	GD03C-1190	12	102	55	40	45	●				
	5	GD05C-1190	12	118	71	56	45	●				
	8	GD08C-1190	12	162	114	99	45	○				
12.0	3	External coolant	GD03-1200	12	102	55	40	45	M14×2		●	
	5		GD05-1200	12	118	71	56	45			●	
	3	GD03C-1200	12	102	55	40	45	●				
	5	GD05C-1200	12	118	71	56	45	●				
	8	GD08C-1200	12	162	114	99	45	○				

● Stock available ○ Make-to-order

Drilling tools

GD series



Drill diameter d ₁ (mm)	Drilling depth (l/d)	Cooling mode	Shank type	Type	Basic dimension(mm)					Suitable for thread		Grade		
					Shank diameter	Overall length	Flute length	Recommended drilling depth	Shank length	cutting taps / tread milling cutters	forming taps			
					d ₂ (h ₆)	l ₁	l ₂	l ₃	l ₄					
12.1	3	External coolant	Straight shank	GD03-1210	14	107	60	43	45	9/16-12UNC	1/2-20UNF	●		
	5			GD05-1210	14	124	77	60	45			●		
	3	Internal coolant		GD03C-1210	14	107	60	43	45			●		
	5			GD05C-1210	14	124	77	60	45			●		
12.2	3	External coolant		GD03-1220	14	107	60	43	45			M14×1.5		●
	5			GD05-1220	14	124	77	60	45					●
	3	Internal coolant		GD03C-1220	14	107	60	43	45					●
	5			GD05C-1220	14	124	77	60	45					●
12.25	3	External coolant	GD03-1225	14	107	60	43	45		●				
	5		GD05-1225	14	124	77	60	45		●				
	3	Internal coolant	GD03C-1225	14	107	60	43	45		●				
	5		GD05C-1225	14	124	77	60	45		●				
12.3	3	External coolant	GD03-1230	14	107	60	43	45			●			
	5		GD05-1230	14	124	77	60	45			●			
	3	Internal coolant	GD03C-1230	14	107	60	43	45			●			
	5		GD05C-1230	14	124	77	60	45			●			
12.5	3	External coolant	GD03-1250	14	107	60	43	45			●			
	5		GD05-1250	14	124	77	60	45			●			
	3	Internal coolant	GD03C-1250	14	107	60	43	45			●			
	5		GD05C-1250	14	124	77	60	45			●			
12.7	8		GD08C-1250	14	178	133	116	45			○			
	3	External coolant	GD03-1270	14	107	60	43	45			●			
	5		GD05-1270	14	124	77	60	45			●			
	3	Internal coolant	GD03C-1270	14	107	60	43	45			●			
5	GD05C-1270		14	124	77	60	45	●						
12.75	8		GD08C-1270	14	178	133	116	45			○			
	3	External coolant	GD03-1275	14	107	60	43	45			●			
	5		GD05-1275	14	124	77	60	45			●			
	3	Internal coolant	GD03C-1275	14	107	60	43	45			●			
5	GD05C-1275		14	124	77	60	45	●						
12.8	3	External coolant	GD03-1280	14	107	60	43	45			●			
	5		GD05-1280	14	124	77	60	45			●			
	3	Internal coolant	GD03C-1280	14	107	60	43	45			●			
	5		GD05C-1280	14	124	77	60	45			●			
12.8	8		GD08C-1280	14	178	133	116	45			○			

Note: For drilling depth (l/d) of 8 ,namely GD08C series, tolerance of shank diameter is hs.

● Stock available ○ Make-to-order

Drilling tools

GD series

➤ Applicable material table

⊙Very suitable ○Suitable

Grade	Workpiece material										
	Mild steel HB ≤ 180	Carbon steel, Alloy steel	Pre-hardened steel, Hardened steel			Stainless steel	Cast iron	Nodular cast iron	Aluminum alloy	Copper alloy	Heat resistant alloy
			~40HRC	~50HRC	~60HRC						
KDG3013	○	⊙	⊙			○	⊙	⊙		○	

Code key

C6

Cutting parameters
C79-C80

Technical information
C87-C93

Non-standard customization tools
C94-C98



BORING TOOL / Drilling Tools

GD series

GD series General machining

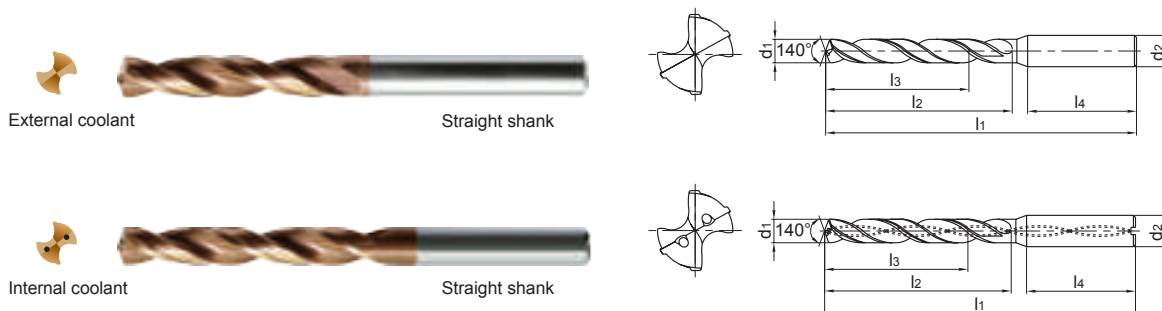

● Suitable for high efficiency drilling in a variety of materials e.g steel, stainless steel, cast iron.

Drill diameter d1(m7)	Drilling depth (l/d)	Cooling mode	Shank type	Type	Basic dimension(mm)					Suitable for thread		Grade	
					Shank diameter d2(h6)	Overall length l1	Flute length l2	Recommended drilling depth l3	Shank length l4	cutting taps / tread milling cutters	forming taps		
													KDG3013
12.9	3	External coolant	Straight shank	GD03-1290	14	107	60	43	45	9/16-18UNF		●	
	5			GD05-1290	14	124	77	60	45			●	
	3	Internal coolant		GD03C-1290	14	107	60	43	45			●	
	5			GD05C-1290	14	124	77	60	45			●	
13.0	3	External coolant		GD03-1300	14	107	60	43	45			●	
	5			GD05-1300	14	124	77	60	45		●		
	3	Internal coolant		GD03C-1300	14	107	60	43	45			●	
	5			GD05C-1300	14	124	77	60	45		●		
13.1	8			GD08C-1300	14	178	133	116	45			○	
	3	External coolant		GD03-1310	14	107	60	43	45		M14×2		●
	5			GD05-1310	14	124	77	60	45			●	
	3	Internal coolant		GD03C-1310	14	107	60	43	45				●
5	GD05C-1310		14	124	77	60	45		●				
13.35	3	External coolant	GD03-1335	14	107	60	43	45		M14×1.5 9/16-12UNC		●	
	5		GD05-1335	14	124	77	60	45			●		
	3	Internal coolant	GD03C-1335	14	107	60	43	45				●	
	5		GD05C-1335	14	124	77	60	45			●		
13.5	3	External coolant	GD03-1350	14	107	60	43	45		5/8-11UNC		●	
	5		GD05-1350	14	124	77	60	45			●		
	3	Internal coolant	GD03C-1350	14	107	60	43	45				●	
	5		GD05C-1350	14	124	77	60	45			●		
13.65	8		GD08C-1350	14	178	133	116	45			○		
	3	External coolant	GD03-1365	14	107	60	43	45		9/16-18UNF		●	
	5		GD05-1365	14	124	77	60	45			●		
	3	Internal coolant	GD03C-1365	14	107	60	43	45				●	
5	GD05C-1365		14	124	77	60	45		●				

● Stock available ○ Make-to-order

Drilling tools
GD series



BORING TOOL / Drilling Tools

GD series

GD series General machining

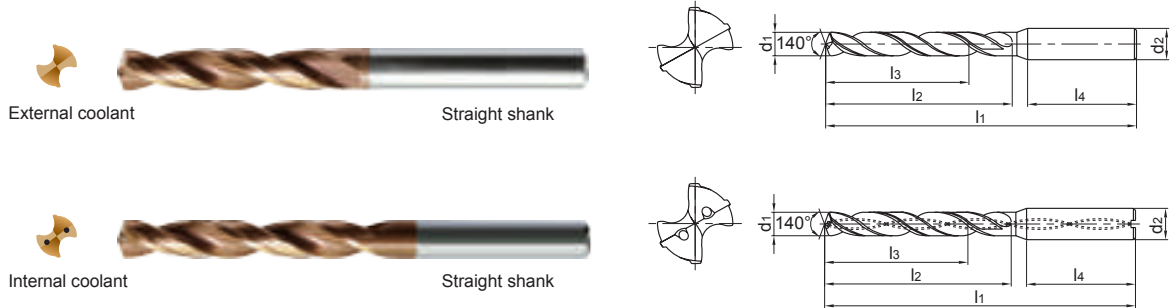

● Suitable for high efficiency drilling in a variety of materials e.g steel, stainless steel, cast iron.

Drill diameter d1(m7)	Drilling depth (l/d)	Cooling mode	Shank type	Type	Basic dimension(mm)					Suitable for thread		Grade
					Shank diameter d2(h6)	Overall length l1	Flute length l2	Recommended drilling depth l3	Shank length l4	cutting taps / tread milling cutters	forming taps	
15.1	3	External coolant	Straight shank	GD03-1510	16	115	65	45	48		M16×2	●
	5			GD05-1510	16	133	83	63	48			●
	3	Internal coolant		GD03C-1510	16	115	65	45	48			●
	5			GD05C-1510	16	133	83	63	48			●
15.25	3	External coolant		GD03-1525	16	115	65	45	48		5/8-18UNF	●
	5			GD05-1525	16	133	83	63	48			●
	3	Internal coolant		GD03C-1525	16	115	65	45	48			●
	5			GD05C-1525	16	133	83	63	48			●
15.35	3	External coolant	GD03-1535	16	115	65	45	48		M16×1.5	●	
	5		GD05-1535	16	133	83	63	48			●	
	3	Internal coolant	GD03C-1535	16	115	65	45	48			●	
	5		GD05C-1535	16	133	83	63	48			●	
15.5	3	External coolant	GD03-1550	16	115	65	45	48	M18×2.5		●	
	5		GD05-1550	16	133	83	63	48			●	
	3	Internal coolant	GD03C-1550	16	115	65	45	48			●	
	5		GD05C-1550	16	133	83	63	48			●	
	8		GD08C-1550	16	204	152	132	48			○	
15.8	3	External coolant	GD03-1580	16	115	65	45	48			●	
	5		GD05-1580	16	133	83	63	48			●	
	3	Internal coolant	GD03C-1580	16	115	65	45	48			●	
	5		GD05C-1580	16	133	83	63	48			●	
16.0	3	External coolant	GD03-1600	16	115	65	45	48	M18×2		●	
	5		GD05-1600	16	133	83	63	48			●	
	3	Internal coolant	GD03C-1600	16	115	65	45	48			●	
	5		GD05C-1600	16	133	83	63	48			●	
	8		GD08C-1600	16	204	152	132	48			○	

● Stock available ○ Make-to-order

Drilling tools

GD series



Drill diameter d ₁ (mm)	Drilling depth (l/d)	Cooling mode	Shank type	Type	Basic dimension(mm)					Suitable for thread		Grade
					Shank diameter	Overall length	Flute length	Recommended drilling depth	Shank length	cutting taps / tread milling cutters	forming taps	
					d ₂ (h ₆)	l ₁	l ₂	l ₃	l ₄			
16.5	3	External coolant	Straight shank	GD03-1650	18	123	73	51	48	3/4-10UNC	M18×2.5	●
	5			GD05-1650	18	143	93	71	48			●
	3	GD03C-1650		18	123	73	51	48	●			
	5	GD05C-1650		18	143	93	71	48	●			
	8	GD08C-1650		18	223	171	149	48	○			
16.75	3	External coolant		GD03-1675	18	123	73	51	48			●
	5			GD05-1675	18	143	93	71	48			●
	3	Internal coolant		GD03C-1675	18	123	73	51	48			●
	5			GD05C-1675	18	143	93	71	48			●
16.8	3	External coolant		GD03-1680	18	123	73	51	48			●
	5		GD05-1680	18	143	93	71	48	●			
	3	Internal coolant	GD03C-1680	18	123	73	51	48	●			
	5		GD05C-1680	18	143	93	71	48	●			
17.0	3	External coolant	GD03-1700	18	123	73	51	48	●			
	5		GD05-1700	18	143	93	71	48	●			
	3	Internal coolant	GD03C-1700	18	123	73	51	48	●			
	5		GD05C-1700	18	143	93	71	48	●			
	8		GD08C-1700	18	223	171	149	48	○			
17.5	3	External coolant	GD03-1750	18	123	73	51	48	●			
	5		GD05-1750	18	143	93	71	48	●			
	3	Internal coolant	GD03C-1750	18	123	73	51	48	●			
	5		GD05C-1750	18	143	93	71	48	●			
	8		GD08C-1750	18	223	171	149	48	○			
17.8	3	External coolant	GD03-1780	18	123	73	51	48	●			
	5		GD05-1780	18	143	93	71	48	●			
	3	Internal coolant	GD03C-1780	18	123	73	51	48	●			
	5		GD05C-1780	18	143	93	71	48	●			
17.9	3	External coolant	GD03-1790	18	123	73	51	48	●			
	5		GD05-1790	18	143	93	71	48	●			
	3	Internal coolant	GD03C-1790	18	123	73	51	48	●			
	5		GD05C-1790	18	143	93	71	48	●			
18.0	3	External coolant	GD03-1800	18	123	73	51	48	●			
	5		GD05-1800	18	143	93	71	48	●			
	3	Internal coolant	GD03C-1800	18	123	73	51	48	●			
	5		GD05C-1800	18	143	93	71	48	●			
	8		GD08C-1800	18	223	171	149	48	○			

Note: For drilling depth (l/d) of 8 ,namely GD08C series, tolerance of shank diameter is h₈. ● Stock available ○ Make-to-order

➤ Applicable material table

● Very suitable ○ Suitable

Grade	Workpiece material										
	Mild steel HB ≤ 180	Carbon steel, Alloy steel	Pre-hardened steel, Hardened steel			Stainless steel	Cast iron	Nodular cast iron	Aluminum alloy	Copper alloy	Heat resistant alloy
			~40HRC	~50HRC	~60HRC						
KDG3013	○	●	●			○	●	●		○	

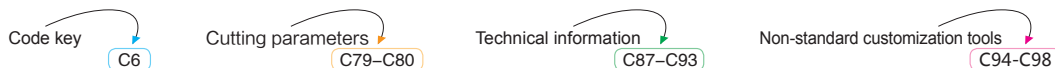

Drilling tools
GD series



BORING TOOL / Drilling Tools

GD series

GD series General machining

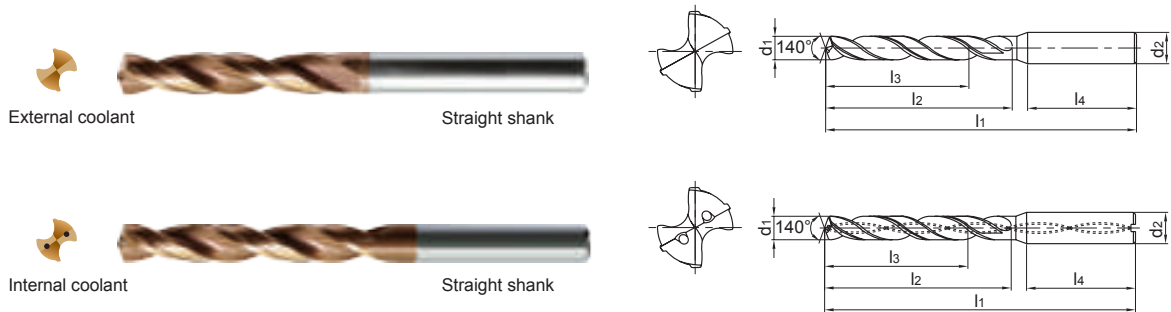

● Suitable for high efficiency drilling in a variety of materials e.g steel, stainless steel, cast iron.

Drill diameter d1(m7)	Drilling depth (l/d)	Cooling mode	Shank type	Type	Basic dimension(mm)					Suitable for thread		Grade
					Shank diameter d2(h6)	Overall length l1	Flute length l2	Recommended drilling depth l3	Shank length l4	cutting taps / tread milling cutters	forming taps	
18.3	3	External coolant	Straight shank	GD03-1830	20	131	79	55	50		3/4-16UNF	●
	5			GD05-1830	20	153	101	77	50			●
	3	Internal coolant		GD03C-1830	20	131	79	55	50			●
	5			GD05C-1830	20	153	101	77	50			●
18.5	3	External coolant		GD03-1850	20	131	79	55	50			●
	5			GD05-1850	20	153	101	77	50			●
	3	Internal coolant		GD03C-1850	20	131	79	55	50			●
	5			GD05C-1850	20	153	101	77	50			●
18.8	3	External coolant	GD03-1880	20	131	79	55	50		M20×2.5	●	
	5		GD05-1880	20	153	101	77	50			●	
	3	Internal coolant	GD03C-1880	20	131	79	55	50			●	
	5		GD05C-1880	20	153	101	77	50			●	
19.0	3	External coolant	GD03-1900	20	131	79	55	50			●	
	5		GD05-1900	20	153	101	77	50			●	
	3	Internal coolant	GD03C-1900	20	131	79	55	50			●	
	5		GD05C-1900	20	153	101	77	50			●	
19.5	3	External coolant	GD03-1950	20	131	79	55	50	M22×2.5 7/8-9UNC		●	
	5		GD05-1950	20	153	101	77	50			●	
	3	Internal coolant	GD03C-1950	20	131	79	55	50			●	
	5		GD05C-1950	20	153	101	77	50			●	
19.8	3	External coolant	GD03-1980	20	131	79	55	50			●	
	5		GD05-1980	20	153	101	77	50			●	
	3	Internal coolant	GD03C-1980	20	131	79	55	50			●	
	5		GD05C-1980	20	153	101	77	50			●	
20.0	3	External coolant	GD03-2000	20	131	79	55	50	M22×2		●	
	5		GD05-2000	20	153	101	77	50			●	
	3	Internal coolant	GD03C-2000	20	131	79	55	50			●	
	5		GD05C-2000	20	153	101	77	50			●	

● Stock available ○ Make-to-order

Drilling tools

GD series



Drill diameter d ₁ (m7)	Drilling depth (l/d)	Cooling mode	Shank type	Type	Basic dimension(mm)					Suitable for thread		Grade
					Shank diameter	Overall length	Flute length	Recommended drilling depth	Shank length	cutting taps / tread milling cutters	forming taps	
					d ₂ (h6)	l ₁	l ₂	l ₃	l ₄			
20.4	3	External coolant	Straight shank	GD03-2040	20	141	86	60	50	7/8-14UNF		○
	5			GD05-2040	20	167	112	85	50			○
	3	Internal coolant		GD03C-2040	20	141	86	60	50			○
	5			GD05C-2040	20	167	112	85	50			○
20.5	3	External coolant		GD03-2050	20	141	86	60	50			○
	5			GD05-2050	20	167	112	85	50			○
	3	Internal coolant		GD03C-2050	20	141	86	60	50			○
	5			GD05C-2050	20	167	112	85	50			○
21.0	3	External coolant	GD03-2100	20	141	86	60	50	M24×3	7/8-9UNC	○	
	5		GD05-2100	20	167	112	85	50			○	
	3	Internal coolant	GD03C-2100	20	141	86	60	50			○	
	5		GD05C-2100	20	167	112	85	50			○	
21.4	3	External coolant	GD03-2140	20	141	86	60	50		7/8-14UNF	○	
	5		GD05-2140	20	167	112	85	50			○	
	3	Internal coolant	GD03C-2140	20	141	86	60	50			○	
	5		GD05C-2140	20	167	112	85	50			○	
21.5	3	External coolant	GD03-2150	20	141	86	60	50			○	
	5		GD05-2150	20	167	112	85	50			○	
	3	Internal coolant	GD03C-2150	20	141	86	60	50			○	
	5		GD05C-2150	20	167	112	85	50			○	
22.0	3	External coolant	GD03-2200	20	141	86	60	50	M24×2		○	
	5		GD05-2200	20	167	112	85	50			○	
	3	Internal coolant	GD03C-2200	20	141	86	60	50			○	
	5		GD05C-2200	20	167	112	85	50			○	
22.25	3	External coolant	GD03-2225	25	153	95	65	56	1-8UNC		○	
	5		GD05-2225	25	184	126	98	56			○	
	3	Internal coolant	GD03C-2225	25	153	95	65	56			○	
	5		GD05C-2225	25	184	126	98	56			○	
22.5	3	External coolant	GD03-2250	25	153	95	65	56			○	
	5		GD05-2250	25	184	126	98	56			○	
	3	Internal coolant	GD03C-2250	25	153	95	65	56			○	
	5		GD05C-2250	25	184	126	98	56			○	
23.0	3	External coolant	GD03-2300	25	153	95	65	56	M25×2		○	
	5		GD05-2300	25	184	126	98	56			○	
	3	Internal coolant	GD03C-2300	25	153	95	65	56			○	
	5		GD05C-2300	25	184	126	98	56			○	

Note: For drilling depth (l/d) of 8 ,namely GD08C series, tolerance of shank diameter is hs.

● Stock available ○ Make-to-order

➤ Applicable material table

● Very suitable ○ Suitable

Grade	Workpiece material										
	Mild steel HB ≤ 180	Carbon steel, Alloy steel	Pre-hardened steel, Hardened steel			Stainless steel	Cast iron	Nodular cast iron	Aluminum alloy	Copper alloy	Heat resistant alloy
			~40HRC	~50HRC	~60HRC						
KDG3013	○	●	●			○	●	●		○	

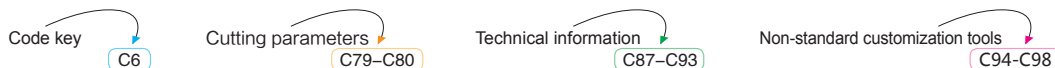

Drilling tools
GD series



BORING TOOL / Drilling Tools

GD series

GD series General machining

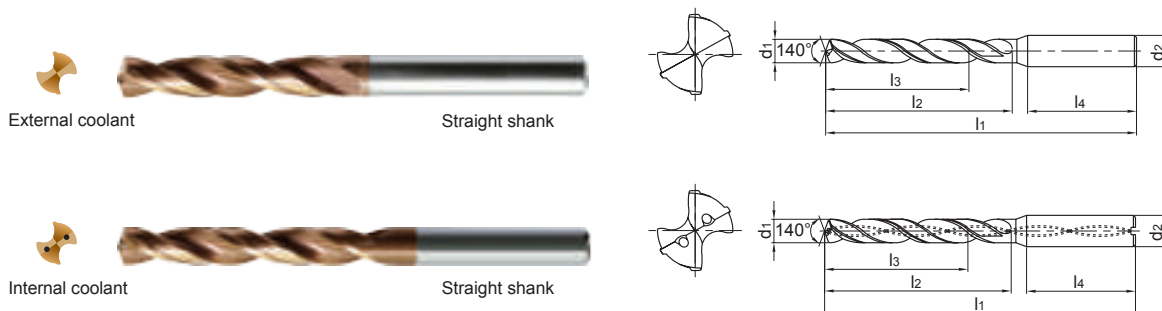

● Suitable for high efficiency drilling in a variety of materials e.g steel, stainless steel, cast iron.

Drill diameter d1(m7)	Drilling depth (l/d)	Cooling mode	Shank type	Type	Basic dimension(mm)					Suitable for thread		Grade
					Shank diameter d2(h6)	Overall length l1	Flute length l2	Recommended drilling depth l3	Shank length l4	cutting taps / tread milling cutters	forming taps	
23.25	3	External coolant	Straight shank	GD03-2325	25	153	95	65	56	1-12UNF		○
	5			GD05-2325	25	184	126	98	56		○	
	3	Internal coolant		GD03C-2325	25	153	95	65	56		○	
	5			GD05C-2325	25	184	126	98	56		○	
23.5	3	External coolant		GD03-2350	25	153	95	65	56		○	
	5			GD05-2350	25	184	126	98	56		○	
	3	Internal coolant		GD03C-2350	25	153	95	65	56		○	
	5			GD05C-2350	25	184	126	98	56		○	
24.0	3	External coolant	GD03-2400	25	153	95	65	56	M27×3	1-8UNC	○	
	5		GD05-2400	25	184	126	98	56			○	
	3	Internal coolant	GD03C-2400	25	153	95	65	56			○	
	5		GD05C-2400	25	184	126	98	56			○	
24.5	3	External coolant	GD03-2450	25	153	95	65	56		1-12UNF	○	
	5		GD05-2450	25	184	126	98	56			○	
	3	Internal coolant	GD03C-2450	25	153	95	65	56			○	
	5		GD05C-2450	25	184	126	98	56			○	
25.0	3	External coolant	GD03-2500	25	153	95	65	56	M27×2		○	
	5		GD05-2500	25	184	126	98	56			○	
	3	Internal coolant	GD03C-2500	25	153	95	65	56			11/8-7UNC	○
	5		GD05C-2500	25	184	126	98	56				○

Note: For drilling depth (l/d) of 8 ,namely GD08C series, tolerance of shank diameter is h8.

● Stock available ○ Make-to-order

Applicable material table

◎ Very suitable ○ Suitable

Grade	Workpiece material										
	Mild steel HB ≤ 180	Carbon steel, Alloy steel	Pre-hardened steel, Hardened steel			Stainless steel	Cast iron	Nodular cast iron	Aluminum alloy	Copper alloy	Heat resistant alloy
			~40HRC	~50HRC	~60HRC						
KDG3013	○	◎	◎			○	◎	◎			○

Code key C6 Cutting parameters C79-C80 Technical information C87-C93 Non-standard customization tools C94-C98

Achieving the optimization of tool structure through analysis of simulated cutting.

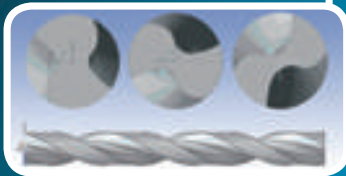

Design with change parameter helical flute, good rigidity and chip removal capability.

Unique cutting edge design, good chip breaking capability even for sticky, softer materials, high versatility.



Double special guiding margin, more credible guiding and more stable machining.

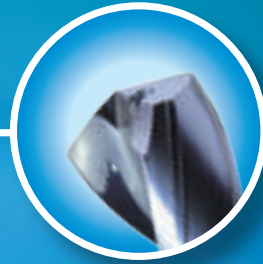

Special nano structure coating with better self lubricating capability and superb wear resistance.



1588SL series deep hole twist drills

1588SL series deep hole twist drills

Outstandingly chip breaking capability



Work piece: crank shaft
 Work piece material: 40Cr
 Machining area: inclined oil hole
 Tool type: 1588SL20C-0690/KDG303
 Cutting parameters: $V_c = 80 \sim 120 \text{ m/min}$
 $f_r = 0.2 \sim 0.4 \text{ mm/r}$
 Cooling system: Water soluble liquid
 Drilling depth: 105mm

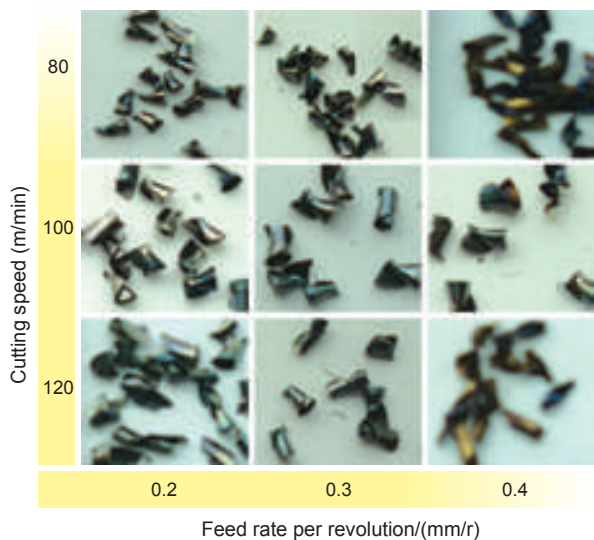

Good chip breaking capability and stable machining with different cutting speed and feed rate.

Extremely high efficiency and long tool life



Work piece: cylinder
 Work material: HT300
 Machined area: crank shaft joint surface drilling
 Drilling depth: 30mm
 Tool type: 1588SL12C-0850/KDG303
 Recommend parameters: $V_c = 80 \text{ m/min}$ $f_r = 0.2 \text{ mm/r}$
 Cooling system: water-soluble liquid

Comparison of tool life(number of machined holes)

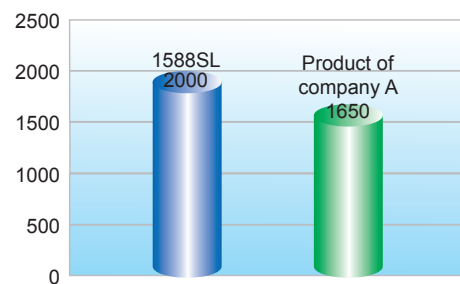

Comparison of tool life(tool wear)



1588SL(regular wear)



Product of company A(falling)

Good cutting performance

Tool type: 1588SL12C-0850/KDG303
 Feed rate: 0.2mm/r Drilling depth: 72mm
 Work material: 42CrMo(HB250)
 Cooling system: Emulsified liquid
 Cutting speed: 80m/min
 Machine equipment: Vertical machining center

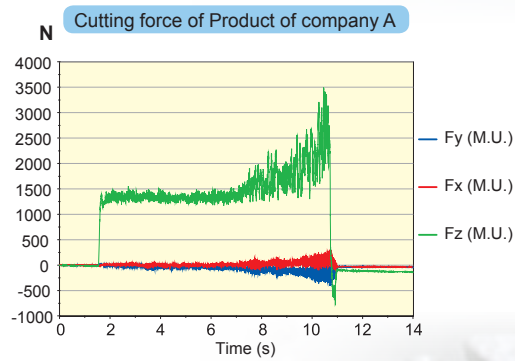
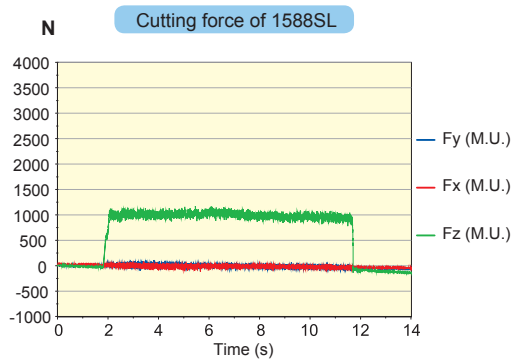

Stable machining precision



Workpiece: Die
 Machined materials: 738H
 Machined area: Hole of sidewall
 Drilling depth: 70mm
 Tool type: 1588SL12C-0600/KDG303
 Recommended parameters: $V_c=85\text{m/min}$, $f_r=0.2\text{mm/r}$
 Cooling system: Water-soluble liquid

Comparison of Machined Hole's Accuracy

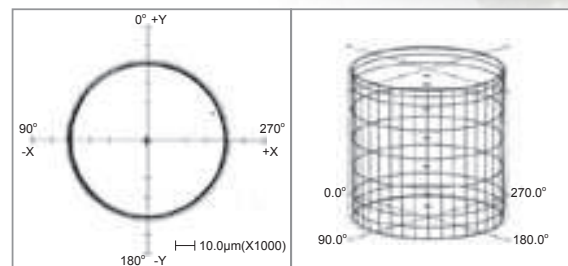

1588SL

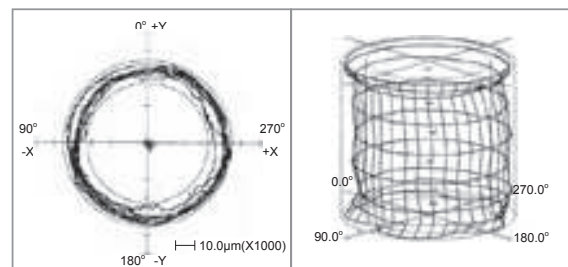

Product of company A



SL series Deep-hole machining



Internal coolant

Straight shank

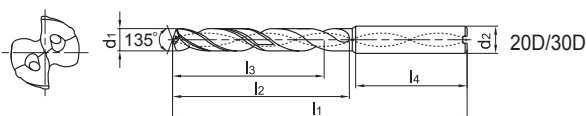
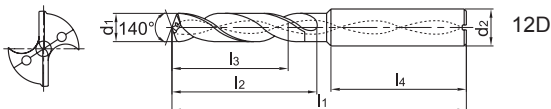

● Suitable for deep-hole drilling of steel, cast iron etc.

Drill diameter d ₁ 12D(m ₇) 20D/30D(h ₇)	Drilling depth (l/d)	Type	Basic dimension(mm)				
			Shank diameter	Overall length	Flute length	Recommended drilling depth	Shank length
			d ₂ (h ₅)	l ₁	l ₂	l ₃	l ₄
3.0	12	1588SL12C-0300	6	90	50	40	36
	20	1588SL20C-0300	6	110	70	62	36
	30	1588SL30C-0300	6	140	100	92	36
3.1	12	1588SL12C-0310	6	90	50	40	36
	20	1588SL20C-0310	6	123	83	72	36
	30	1588SL30C-0310	6	160	120	108	36
3.2	12	1588SL12C-0320	6	90	50	40	36
	20	1588SL20C-0320	6	123	83	72	36
	30	1588SL30C-0320	6	160	120	108	36
3.3	12	1588SL12C-0330	6	90	50	40	36
	20	1588SL20C-0330	6	123	83	72	36
	30	1588SL30C-0330	6	160	120	108	36
3.4	12	1588SL12C-0340	6	90	50	40	36
	20	1588SL20C-0340	6	123	83	72	36
	30	1588SL30C-0340	6	160	120	108	36
3.5	12	1588SL12C-0350	6	90	50	40	36
	20	1588SL20C-0350	6	123	83	72	36
	30	1588SL30C-0350	6	160	120	108	36
3.6	12	1588SL12C-0360	6	90	50	40	36
	20	1588SL20C-0360	6	136	96	84	36
	30	1588SL30C-0360	6	176	136	124	36
3.7	12	1588SL12C-0370	6	90	50	46	36
	20	1588SL20C-0370	6	136	96	84	36
	30	1588SL30C-0370	6	176	136	124	36
3.8	12	1588SL12C-0380	6	90	50	46	36
	20	1588SL20C-0380	6	136	96	84	36
	30	1588SL30C-0380	6	176	136	124	36
3.9	12	1588SL12C-0390	6	90	50	46	36
	20	1588SL20C-0390	6	136	96	84	36
	30	1588SL30C-0390	6	176	136	124	36
4.0	12	1588SL12C-0400	6	102	64	56	36
	20	1588SL20C-0400	6	136	96	84	36
	30	1588SL30C-0400	6	176	136	124	36
4.1	12	1588SL12C-0410	6	102	64	56	36
	20	1588SL20C-0410	6	148	108	96	36
	30	1588SL30C-0410	6	192	152	140	36

Drill diameter d ₁ 12D(m ₇) 20D/30D(h ₇)	Drilling depth (l/d)	Type	Basic dimension(mm)				
			Shank diameter	Overall length	Flute length	Recommended drilling depth	Shank length
			d ₂ (h ₅)	l ₁	l ₂	l ₃	l ₄
4.2	12	1588SL12C-0420	6	102	64	56	36
	20	1588SL20C-0420	6	148	108	96	36
	30	1588SL30C-0420	6	192	152	140	36
4.3	12	1588SL12C-0430	6	102	64	56	36
	20	1588SL20C-0430	6	148	108	96	36
	30	1588SL30C-0430	6	192	152	140	36
4.4	12	1588SL12C-0440	6	102	64	56	36
	20	1588SL20C-0440	6	148	108	96	36
	30	1588SL30C-0440	6	192	152	140	36
4.5	12	1588SL12C-0450	6	102	64	56	36
	20	1588SL20C-0450	6	148	108	96	36
	30	1588SL30C-0450	6	192	152	140	36
4.6	12	1588SL12C-0460	6	102	64	56	36
	20	1588SL20C-0460	6	158	118	106	36
	30	1588SL30C-0460	6	208	168	156	36
4.7	12	1588SL12C-0470	6	102	64	56	36
	20	1588SL20C-0470	6	158	118	106	36
	30	1588SL30C-0470	6	208	168	156	36
4.8	12	1588SL12C-0480	6	102	64	56	36
	20	1588SL20C-0480	6	158	118	106	36
	30	1588SL30C-0480	6	208	168	156	36
4.9	12	1588SL12C-0490	6	102	64	56	36
	20	1588SL20C-0490	6	158	118	106	36
	30	1588SL30C-0490	6	208	168	156	36
5.0	12	1588SL12C-0500	6	116	78	72	36
	20	1588SL20C-0500	6	158	118	106	36
	30	1588SL30C-0500	6	208	168	156	36
5.1	12	1588SL12C-0510	6	116	78	72	36
	20	1588SL20C-0510	6	168	128	116	36
	30	1588SL30C-0510	6	228	188	170	36
5.2	12	1588SL12C-0520	6	116	78	72	36
	20	1588SL20C-0520	6	168	128	116	36
	30	1588SL30C-0520	6	228	188	170	36
5.3	12	1588SL12C-0530	6	116	78	72	36
	20	1588SL20C-0530	6	168	128	116	36
	30	1588SL30C-0530	6	228	188	170	36

Drilling tools

SL series



Drill diameter d ₁ 12D(m _r) 20D/30D(h _r)	Drilling depth (l/d)	Type	Basic dimension(mm)				
			Shank diameter	Overall length	Flute length	Recommended drilling depth	
						l ₃	l ₄
d ₂ (h _s)	l ₁	l ₂	l ₃	l ₄			
5.4	12	1588SL12C-0540	6	116	78	72	36
	20	1588SL20C-0540	6	168	128	116	36
	30	1588SL30C-0540	6	228	188	170	36
5.5	12	1588SL12C-0550	6	116	78	72	36
	20	1588SL20C-0550	6	168	128	116	36
	30	1588SL30C-0550	6	228	188	170	36
5.6	12	1588SL12C-0560	6	116	78	72	36
	20	1588SL20C-0560	6	180	140	126	36
	30	1588SL30C-0560	6	240	200	182	36
5.7	12	1588SL12C-0570	6	116	78	72	36
	20	1588SL20C-0570	6	180	140	126	36
	30	1588SL30C-0570	6	240	200	182	36
5.8	12	1588SL12C-0580	6	116	78	72	36
	20	1588SL20C-0580	6	180	140	126	36
	30	1588SL30C-0580	6	240	200	182	36
5.9	12	1588SL12C-0590	6	116	78	72	36
	20	1588SL20C-0590	6	180	140	126	36
	30	1588SL30C-0590	6	240	200	182	36
6.0	12	1588SL12C-0600	6	116	78	72	36
	20	1588SL20C-0600	6	180	140	126	36
	30	1588SL30C-0600	6	240	200	182	36
6.1	12	1588SL12C-0610	8	131	93	84	36
	20	1588SL20C-0610	8	192	150	132	36
	30	1588SL30C-0610	8	260	220	202	36
6.2	12	1588SL12C-0620	8	131	93	84	36
	20	1588SL20C-0620	8	192	150	132	36
	30	1588SL30C-0620	8	260	220	202	36
6.3	12	1588SL12C-0630	8	131	93	84	36
	20	1588SL20C-0630	8	192	150	132	36
	30	1588SL30C-0630	8	260	220	202	36
6.4	12	1588SL12C-0640	8	131	93	84	36
	20	1588SL20C-0640	8	192	150	132	36
	30	1588SL30C-0640	8	260	220	202	36
6.5	12	1588SL12C-0650	8	131	93	84	36
	20	1588SL20C-0650	8	192	150	132	36
	30	1588SL30C-0650	8	260	220	202	36
6.6	12	1588SL12C-0660	8	131	93	84	36
	20	1588SL20C-0660	8	202	162	144	36
	30	1588SL30C-0660	8	272	232	214	36
6.7	12	1588SL12C-0670	8	131	93	84	36
	20	1588SL20C-0670	8	202	162	144	36
	30	1588SL30C-0670	8	272	232	214	36
6.8	12	1588SL12C-0680	8	131	93	84	36
	20	1588SL20C-0680	8	202	162	144	36
	30	1588SL30C-0680	8	272	232	214	36
6.9	12	1588SL12C-0690	8	131	93	84	36
	20	1588SL20C-0690	8	202	162	144	36
	30	1588SL30C-0690	8	272	232	214	36
7.0	12	1588SL12C-0700	8	131	93	84	36
	20	1588SL20C-0700	8	202	162	144	36
	30	1588SL30C-0700	8	272	232	214	36
7.1	12	1588SL12C-0710	8	146	108	96	36
	20	1588SL20C-0710	8	213	173	155	36
	30	1588SL30C-0710	8	290	250	232	36
7.2	12	1588SL12C-0720	8	146	108	96	36
	20	1588SL20C-0720	8	213	173	155	36
	30	1588SL30C-0720	8	290	250	232	36
7.3	12	1588SL12C-0730	8	146	108	96	36
	20	1588SL20C-0730	8	213	173	155	36
	30	1588SL30C-0730	8	290	250	232	36
7.4	12	1588SL12C-0740	8	146	108	96	36
	20	1588SL20C-0740	8	213	173	155	36
	30	1588SL30C-0740	8	290	250	232	36
7.5	12	1588SL12C-0750	8	146	108	96	36
	20	1588SL20C-0750	8	213	173	155	36
	30	1588SL30C-0750	8	290	250	232	36
7.6	12	1588SL12C-0760	8	146	108	96	36
	20	1588SL20C-0760	8	223	183	165	36
	30	1588SL30C-0760	8	305	265	246	36
7.7	12	1588SL12C-0770	8	146	108	96	36
	20	1588SL20C-0770	8	223	183	165	36
	30	1588SL30C-0770	8	305	265	246	36

Drilling tools

SL series

▶▶ Applicable material table

○Very suitable ○Suitable

Grade	Workpiece material										
	Mild steel HB≤180	Carbon steel, Alloy steel	Pre-hardened steel, Hardened steel			Stainless steel	Cast iron	Nodular cast iron	Aluminum alloy	Copper alloy	Heat resistant alloy
			~40HRC	~50HRC	~60HRC						
KDG303	○	○	○			○	○	○	○	○	

Code key
C6

Cutting parameters
C81

Technical information
C80-C86

Non-standard customization tools
C94-C98



BORING TOOL / Drilling Tools

SL series

SL series Deep-hole machining



Internal coolant

Straight shank

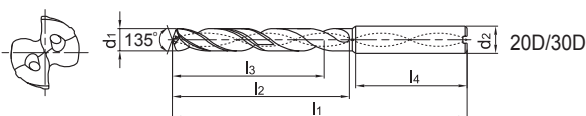
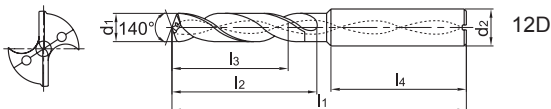

● Suitable for deep-hole drilling of steel, cast iron etc.

Drill diameter d ₁ 12D(m ₇) 20D/30D(h ₇)	Drilling depth (l/d)	Type	Basic dimension(mm)				
			Shank diameter	Overall length	Flute length		Shank length
					l ₁	l ₂	
7.8	12	1588SL12C-0780	8	146	108	96	36
	20	1588SL20C-0780	8	223	183	165	36
	30	1588SL30C-0780	8	305	265	246	36
7.9	12	1588SL12C-0790	8	146	108	96	36
	20	1588SL20C-0790	8	223	183	165	36
	30	1588SL30C-0790	8	305	265	246	36
8.0	12	1588SL12C-0800	8	146	108	96	36
	20	1588SL20C-0800	8	223	183	165	36
	30	1588SL30C-0800	8	305	265	246	36
8.1	12	1588SL12C-0810	10	162	120	108	40
	20	1588SL20C-0810	10	239	195	176	40
	30	1588SL30C-0810	10	330	285	265	40
8.2	12	1588SL12C-0820	10	162	120	108	40
	20	1588SL20C-0820	10	239	195	176	40
	30	1588SL30C-0820	10	330	285	265	40
8.3	12	1588SL12C-0830	10	162	120	108	40
	20	1588SL20C-0830	10	239	195	176	40
	30	1588SL30C-0830	10	330	285	265	40
8.4	12	1588SL12C-0840	10	162	120	108	40
	20	1588SL20C-0840	10	239	195	176	40
	30	1588SL30C-0840	10	330	285	265	40
8.5	12	1588SL12C-0850	10	162	120	108	40
	20	1588SL20C-0850	10	239	195	176	40
	30	1588SL30C-0850	10	330	285	265	40
8.6	12	1588SL12C-0860	10	162	120	108	40
	20	1588SL20C-0860	10	249	205	186	40
	30	1588SL30C-0860	10	340	295	275	40
8.7	12	1588SL12C-0870	10	162	120	108	40
	20	1588SL20C-0870	10	249	205	186	40
	30	1588SL30C-0870	10	340	295	275	40
8.8	12	1588SL12C-0880	10	162	120	108	40
	20	1588SL20C-0880	10	249	205	186	40
	30	1588SL30C-0880	10	340	295	275	40
8.9	12	1588SL12C-0890	10	162	120	108	40
	20	1588SL20C-0890	10	249	205	186	40
	30	1588SL30C-0890	10	340	295	275	40

Drill diameter d ₁ 12D(m ₇) 20D/30D(h ₇)	Drilling depth (l/d)	Type	Basic dimension(mm)				
			Shank diameter	Overall length	Flute length		Shank length
					d ₂ (h ₅)	l ₁	
9.0	12	1588SL12C-0900	10	162	120	108	40
	20	1588SL20C-0900	10	249	205	186	40
	30	1588SL30C-0900	10	340	295	275	40
9.1	12	1588SL12C-0910	10	174	132	120	40
	20	1588SL20C-0910	10	262	218	196	40
	30	1588SL30C-0910	10	360	315	292	40
9.2	12	1588SL12C-0920	10	174	132	120	40
	20	1588SL20C-0920	10	262	218	196	40
	30	1588SL30C-0920	10	360	315	292	40
9.3	12	1588SL12C-0930	10	174	132	120	40
	20	1588SL20C-0930	10	262	218	196	40
	30	1588SL30C-0930	10	360	315	292	40
9.4	12	1588SL12C-0940	10	174	132	120	40
	20	1588SL20C-0940	10	262	218	196	40
	30	1588SL30C-0940	10	360	315	292	40
9.5	12	1588SL12C-0950	10	174	132	120	40
	20	1588SL20C-0950	10	262	218	196	40
	30	1588SL30C-0950	10	360	315	292	40
9.6	12	1588SL12C-0960	10	174	132	120	40
	20	1588SL20C-0960	10	272	228	206	40
	30	1588SL30C-0960	10	372	328	305	40
9.7	12	1588SL12C-0970	10	174	132	120	40
	20	1588SL20C-0970	10	272	228	206	40
	30	1588SL30C-0970	10	372	328	305	40
9.8	12	1588SL12C-0980	10	174	132	120	40
	20	1588SL20C-0980	10	272	228	206	40
	30	1588SL30C-0980	10	372	328	305	40
9.9	12	1588SL12C-0990	10	174	132	120	40
	20	1588SL20C-0990	10	272	228	206	40
	30	1588SL30C-0990	10	372	328	305	40
10.0	12	1588SL12C-1000	10	174	132	120	40
	20	1588SL20C-1000	10	272	228	206	40
	30	1588SL30C-1000	10	372	328	305	40
10.1	12	1588SL12C-1010	12	204	156	144	45
	20	1588SL20C-1010	12	292	242	220	45

Drilling tools

SL series



Drill diameter d ₁ 12D(m _r) 20D/30D(h _r)	Drilling depth (l/d)	Type	Basic dimension(mm)				
			Shank diameter	Overall length	Flute length		Shank length
					l ₁	l ₂	
d ₂ (h _s)							
10.2	12	1588SL12C-1020	12	204	156	144	45
	20	1588SL20C-1020	12	292	242	220	45
10.3	12	1588SL12C-1030	12	204	156	144	45
	20	1588SL20C-1030	12	292	242	220	45
10.4	12	1588SL12C-1040	12	204	156	144	45
	20	1588SL20C-1040	12	292	242	220	45
10.5	12	1588SL12C-1050	12	204	156	144	45
	20	1588SL20C-1050	12	292	242	220	45
10.6	12	1588SL12C-1060	12	204	156	144	45
	20	1588SL20C-1060	12	300	250	228	45
10.7	12	1588SL12C-1070	12	204	156	144	45
	20	1588SL20C-1070	12	300	250	228	45
10.8	12	1588SL12C-1080	12	204	156	144	45
	20	1588SL20C-1080	12	300	250	228	45
10.9	12	1588SL12C-1090	12	204	156	144	45
	20	1588SL20C-1090	12	300	250	228	45
11.0	12	1588SL12C-1100	12	204	156	144	45
	20	1588SL20C-1100	12	300	250	228	45
11.1	12	1588SL12C-1110	12	204	156	144	45
	20	1588SL20C-1110	12	315	265	240	45
11.2	12	1588SL12C-1120	12	204	156	144	45
	20	1588SL20C-1120	12	315	265	240	45
11.3	12	1588SL12C-1130	12	204	156	144	45
	20	1588SL20C-1130	12	315	265	240	45
11.4	12	1588SL12C-1140	12	204	156	144	45
	20	1588SL20C-1140	12	315	265	240	45
11.5	12	1588SL12C-1150	12	204	156	144	45
	20	1588SL20C-1150	12	315	265	240	45
11.6	12	1588SL12C-1160	12	204	156	144	45
	20	1588SL20C-1160	12	325	275	250	45
11.7	12	1588SL12C-1170	12	204	156	144	45
	20	1588SL20C-1170	12	325	275	250	45
11.8	12	1588SL12C-1180	12	204	156	144	45
	20	1588SL20C-1180	12	325	275	250	45
11.9	12	1588SL12C-1190	12	204	156	144	45
	20	1588SL20C-1190	12	325	275	250	45
12.0	12	1588SL12C-1200	12	204	156	144	45
	20	1588SL20C-1200	12	325	275	250	45
12.5	12	1588SL12C-1250	14	230	182	168	45
	20	1588SL20C-1250	14	323	275	250	45
12.7	12	1588SL12C-1270	14	230	182	168	45
	12.8	12	1588SL12C-1280	14	230	182	168
13.0	12	1588SL12C-1300	14	230	182	168	45
	20	1588SL20C-1300	14	338	290	265	45
13.5	12	1588SL12C-1350	14	230	182	168	45
	20	1588SL20C-1350	14	338	290	265	45
14.0	12	1588SL12C-1400	14	230	182	168	45
	20	1588SL20C-1400	14	367	318	290	45
14.5	12	1588SL12C-1450	16	260	208	194	48
15.0	12	1588SL12C-1500	16	260	208	194	48
15.5	12	1588SL12C-1550	16	260	208	194	48
16.0	12	1588SL12C-1600	16	260	208	194	48
16.5	12	1588SL12C-1650	18	286	234	218	48
17.0	12	1588SL12C-1700	18	286	234	218	48
17.5	12	1588SL12C-1750	18	286	234	218	48
18.0	12	1588SL12C-1800	18	286	234	218	48
18.5	12	1588SL12C-1850	20	310	258	240	48
19.0	12	1588SL12C-1900	20	310	258	240	48
19.5	12	1588SL12C-1950	20	310	258	240	48
20.0	12	1588SL12C-2000	20	310	258	240	48

Drilling tools

SL series

➤ Applicable material table

⊙Very suitable ○Suitable

Grade	Workpiece material										
	Mild steel HB≤180	Carbon steel, Alloy steel	Pre-hardened steel, Hardened steel			Stainless steel	Cast iron	Nodular cast iron	Aluminum alloy	Copper alloy	Heat resistant alloy
			~40HRC	~50HRC	~60HRC						
KDG303	○	⊙	⊙			○	⊙	⊙	○	○	

Code key
C6

Cutting parameters
C81

Technical information
C80-C86

Non-standard customization tools
C94-C98



BORING TOOL

Drilling Tools

SP series

1534SP series Guide-hole machining



Internal coolant



Straight shank

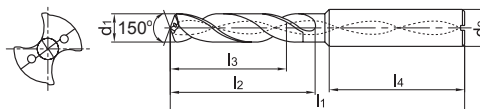

Drill diameter d ₁ (h7)	Drilling depth (l/d)	Type	Basic dimension(mm)					Drill diameter d ₁ (h7)	Drilling depth (l/d)	Type	Basic dimension(mm)				
			Shank diameter	Overall length	Flute length	Recommended drilling depth	Shank length				Shank diameter	Overall length	Flute length	Recommended drilling depth	Shank length
			d ₂ (h5)	l ₁	l ₂	l ₃	l ₄				d ₂ (h5)	l ₁	l ₂	l ₃	l ₄
3.03	3	1534SP03C-0303	6	62	20	14	36	6.63	3	1534SP03C-0663	8	79	34	24	36
3.13	3	1534SP03C-0313	6	62	20	14	36	6.73	3	1534SP03C-0673	8	79	34	24	36
3.23	3	1534SP03C-0323	6	62	20	14	36	6.83	3	1534SP03C-0683	8	79	34	24	36
3.33	3	1534SP03C-0333	6	62	20	14	36	6.93	3	1534SP03C-0693	8	79	34	24	36
3.43	3	1534SP03C-0343	6	62	20	14	36	7.03	3	1534SP03C-0703	8	79	34	24	36
3.53	3	1534SP03C-0353	6	62	20	14	36	7.13	3	1534SP03C-0713	8	79	41	29	36
3.63	3	1534SP03C-0363	6	62	20	14	36	7.23	3	1534SP03C-0723	8	79	41	29	36
3.73	3	1534SP03C-0373	6	62	20	14	36	7.33	3	1534SP03C-0733	8	79	41	29	36
3.83	3	1534SP03C-0383	6	66	24	17	36	7.43	3	1534SP03C-0743	8	79	41	29	36
3.93	3	1534SP03C-0393	6	66	24	17	36	7.53	3	1534SP03C-0753	8	79	41	29	36
4.03	3	1534SP03C-0403	6	66	24	17	36	7.63	3	1534SP03C-0763	8	79	41	29	36
4.13	3	1534SP03C-0413	6	66	24	17	36	7.73	3	1534SP03C-0773	8	79	41	29	36
4.23	3	1534SP03C-0423	6	66	24	17	36	7.83	3	1534SP03C-0783	8	79	41	29	36
4.33	3	1534SP03C-0433	6	66	24	17	36	7.93	3	1534SP03C-0793	8	79	41	29	36
4.43	3	1534SP03C-0443	6	66	24	17	36	8.03	3	1534SP03C-0803	8	79	41	29	36
4.53	3	1534SP03C-0453	6	66	24	17	36	8.13	3	1534SP03C-0813	10	89	47	35	40
4.63	3	1534SP03C-0463	6	66	24	17	36	8.23	3	1534SP03C-0823	10	89	47	35	40
4.73	3	1534SP03C-0473	6	66	24	17	36	8.33	3	1534SP03C-0833	10	89	47	35	40
4.83	3	1534SP03C-0483	6	66	28	20	36	8.43	3	1534SP03C-0843	10	89	47	35	40
4.93	3	1534SP03C-0493	6	66	28	20	36	8.53	3	1534SP03C-0853	10	89	47	35	40
5.03	3	1534SP03C-0503	6	66	28	20	36	8.63	3	1534SP03C-0863	10	89	47	35	40
5.13	3	1534SP03C-0513	6	66	28	20	36	8.73	3	1534SP03C-0873	10	89	47	35	40
5.23	3	1534SP03C-0523	6	66	28	20	36	8.83	3	1534SP03C-0883	10	89	47	35	40
5.33	3	1534SP03C-0533	6	66	28	20	36	8.93	3	1534SP03C-0893	10	89	47	35	40
5.43	3	1534SP03C-0543	6	66	28	20	36	9.03	3	1534SP03C-0903	10	89	47	35	40
5.53	3	1534SP03C-0553	6	66	28	20	36	9.13	3	1534SP03C-0913	10	89	47	35	40
5.63	3	1534SP03C-0563	6	66	28	20	36	9.23	3	1534SP03C-0923	10	89	47	35	40
5.73	3	1534SP03C-0573	6	66	28	20	36	9.33	3	1534SP03C-0933	10	89	47	35	40
5.83	3	1534SP03C-0583	6	66	28	20	36	9.43	3	1534SP03C-0943	10	89	47	35	40
5.93	3	1534SP03C-0593	6	66	28	20	36	9.53	3	1534SP03C-0953	10	89	47	35	40
6.03	3	1534SP03C-0603	6	66	28	20	36	9.63	3	1534SP03C-0963	10	89	47	35	40
6.13	3	1534SP03C-0613	8	79	34	24	36	9.73	3	1534SP03C-0973	10	89	47	35	40
6.23	3	1534SP03C-0623	8	79	34	24	36	9.83	3	1534SP03C-0983	10	89	47	35	40
6.33	3	1534SP03C-0633	8	79	34	24	36	9.93	3	1534SP03C-0993	10	89	47	35	40
6.43	3	1534SP03C-0643	8	79	34	24	36	10.03	3	1534SP03C-1003	10	89	47	35	40
6.53	3	1534SP03C-0653	8	79	34	24	36	10.13	3	1534SP03C-1013	12	102	55	40	45

Drilling tools

SP series



Drill diameter d ₁ (h7)	Drilling depth (l/d)	Type	Basic dimension(mm)				
			Shank diameter	Overall length	Flute length	Recommended drilling depth	Shank length
			d ₂ (h5)	l ₁	l ₂	l ₃	l ₄
10.23	3	1534SP03C-1023	12	102	55	40	45
10.33	3	1534SP03C-1033	12	102	55	40	45
10.43	3	1534SP03C-1043	12	102	55	40	45
10.53	3	1534SP03C-1053	12	102	55	40	45
10.63	3	1534SP03C-1063	12	102	55	40	45
10.73	3	1534SP03C-1073	12	102	55	40	45
10.83	3	1534SP03C-1083	12	102	55	40	45
10.93	3	1534SP03C-1093	12	102	55	40	45
11.03	3	1534SP03C-1103	12	102	55	40	45
11.13	3	1534SP03C-1113	12	102	55	40	45
11.23	3	1534SP03C-1123	12	102	55	40	45
11.33	3	1534SP03C-1133	12	102	55	40	45
11.43	3	1534SP03C-1143	12	102	55	40	45

Drill diameter d ₁ (h7)	Drilling depth (l/d)	Type	Basic dimension(mm)				
			Shank diameter	Overall length	Flute length	Recommended drilling depth	Shank length
			d ₂ (h5)	l ₁	l ₂	l ₃	l ₄
11.53	3	1534SP03C-1153	12	102	55	40	45
11.63	3	1534SP03C-1163	12	102	55	40	45
11.73	3	1534SP03C-1173	12	102	55	40	45
11.83	3	1534SP03C-1183	12	102	55	40	45
11.93	3	1534SP03C-1193	12	102	55	40	45
12.03	3	1534SP03C-1203	12	102	55	40	45
12.53	3	1534SP03C-1253	14	107	60	43	45
12.73	3	1534SP03C-1273	14	107	60	43	45
12.83	3	1534SP03C-1283	14	107	60	43	45
13.03	3	1534SP03C-1303	14	107	60	43	45
13.53	3	1534SP03C-1353	14	107	60	43	45
14.03	3	1534SP03C-1403	14	107	60	43	45

Recommended Machining Method of SL series Deep-hole Drills

1.Hole-guided Machining

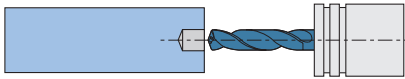

- ◆ Apex angle of drills used for hole-guided machining has to be greater than the apex angle of deep-hole drills.
- ◆ Diameter of drills used for hole-guided machining has to be respectively greater than the diameter of deep-hole drills. Generally the diameter range of deep-hole drills is between 0 and positive 0.1.
- ◆ Generally the depth of pre-drilling hole is 1-3D (D is the diameter of pre-drilling holes). Also, it basically needs to ensure the accuracy of pre-drilling holes at the same time.

2.Deep-hole Machining (Inserting into the Pre-drilling Holes)

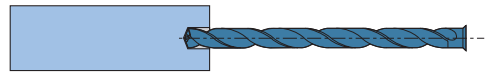

- ◆ lower speed should be applied in the process of inserting deep-hole drills into the pre-drilling holes.
- ◆ Insert deep hole drill to the location 1-3mm away from the bottom of pre-drilling holes (Please make sure that the parts of drilling point are entirely inserted).

3.Deep-hole Machining (Beginning machining, to the end)

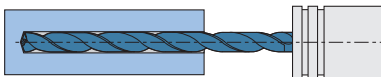

- ◆ Non-stopped machining with fixed speed and feed rates. (Completed at one time, not a “Step-by-Step” machining).

4.Deep-hole Machining (Retract from hole)

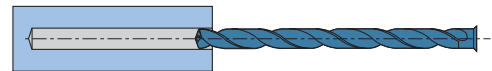

- ◆ Reduce speed located 1-2mm away from hole bottom at the end of machining.
- ◆ Quickly secedes the deep-hole drills back to the location where it begins to machine.
- ◆ Retract under the same conditions of inserting pre-drilling holes.

▶▶ Applicable material table

○Very suitable ○Suitable

Grade	Workpiece material										
	Mild steel HB≤180	Carbon steel, Alloy steel	Pre-hardened steel, Hardened steel			Stainless steel	Cast iron	Nodular cast iron	Aluminum alloy	Copper alloy	Heat resistant alloy
			~40HRC	~50HRC	~60HRC						
KDG303	○	○	○			○	○	○	○	○	

Code key C6 Cutting parameters C82 Technical information C87-C93 Non-standard customization tools C94-C98

ST machining of soft steel and stainless steel series twist drill

ST series drills with superior performance will solve the difficulties in machining of high-elongation materials such as soft steel, stainless steel, etc.

Optimized drill point design with strengthened chisel edge and ensures easy and fast cutting and excellent chip breaking.

Nano-structured TiAlN coating, outstanding wear resistance and heat resistance.

Special chipbreaker with large chip pocket ensures good chip evacuation and smooth drilling.

Application of st series twist drills

Tool type: 1534ST03C-0800
 Workpiece material: 1Cr18Ni9Ti
 Cooling system: oil water emulsion(internal cooling)
 Cutting speed: $V_c=85\text{m/min}$
 Feed rate: $f_r=0.16\text{mm/r}$
 Drilling depth: 24mm(blind hole)

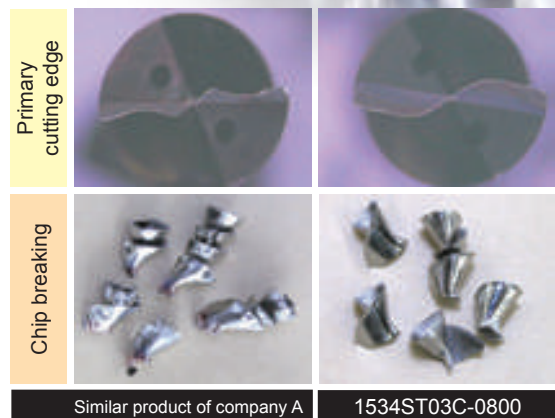
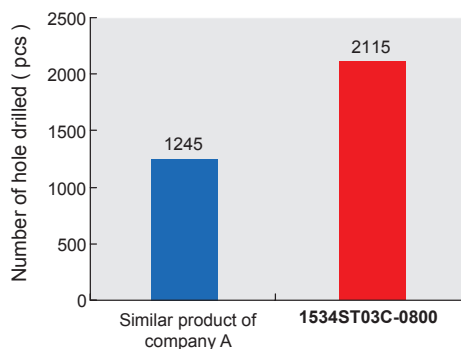



ST series for machining of soft steel, stainless steel

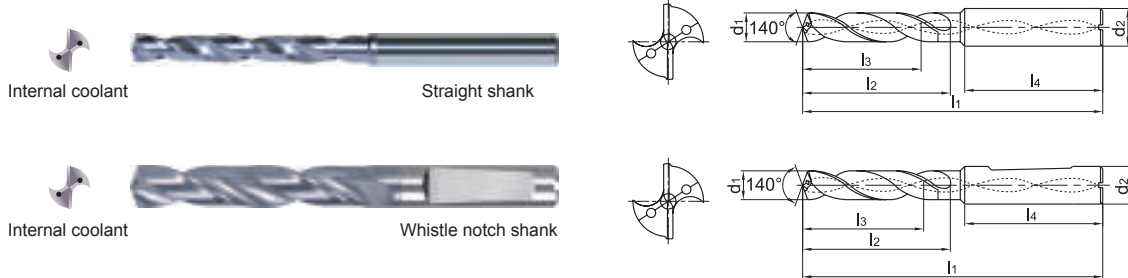

- First choice for drilling soft steel and stainless steel.
- Sharp cutting edge can avoid build-up edge, suitable for drilling hole with high performance.

Drill diameter d ₁ (m7)	Drilling depth (l/d)	Cooling mode	Shank type	Type	Basic dimension(mm)					Recommended grade
					Shank diameter	Overall length	Flute length	Recommended drilling depth	Shank length	
					d ₂ (h ₆)	l ₁	l ₂	l ₃	l ₄	
3.0	3	Internal coolant	Straight shank	1534ST03C-0300	6	62	20	14	36	☆
	5			1536ST05C-0300	6	66	28	23	36	☆
	5		Whistle notch shank	1736ST05C-0300	6	66	28	23	36	☆
3.1	3		Straight shank	1534ST03C-0310	6	62	20	14	36	☆
	5			1536ST05C-0310	6	66	28	23	36	☆
	5		Whistle notch shank	1736ST05C-0310	6	66	28	23	36	☆
3.2	3		Straight shank	1534ST03C-0320	6	62	20	14	36	☆
	5			1536ST05C-0320	6	66	28	23	36	☆
	5		Whistle notch shank	1736ST05C-0320	6	66	28	23	36	☆
3.25	3		Straight shank	1534ST03C-0325	6	62	20	14	36	☆
	5			1536ST05C-0325	6	66	28	23	36	☆
	5		Whistle notch shank	1736ST05C-0325	6	66	28	23	36	☆
3.3	3	Straight shank	1534ST03C-0330	6	62	20	14	36	☆	
	5		1536ST05C-0330	6	66	28	23	36	☆	
	5	Whistle notch shank	1736ST05C-0330	6	66	28	23	36	☆	
3.4	3	Straight shank	1534ST03C-0340	6	62	20	14	36	☆	
	5		1536ST05C-0340	6	66	28	23	36	☆	
	5	Whistle notch shank	1736ST05C-0340	6	66	28	23	36	☆	
3.5	3	Straight shank	1534ST03C-0350	6	62	20	14	36	☆	
	5		1536ST05C-0350	6	66	28	23	36	☆	
	5	Whistle notch shank	1736ST05C-0350	6	66	28	23	36	☆	

☆ Recommended grade (produce according to order)

Drilling tools

ST series

➤ Applicable material table

⊙ Very suitable ○ Suitable

Grade	Workpiece material										
	Mild steel HB≤180	Carbon steel, Alloy steel	Pre-hardened steel, Hardened steel			Stainless steel	Cast iron	Nodular cast iron	Aluminum alloy	Copper alloy	Heat resistant alloy
			~40HRC	~50HRC	~60HRC						
KDG303	⊙	○				⊙					○

Code key

C6

Cutting parameters

C83

Technical information

C87-C93

Non-standard customization tools

C94-C98



BORING TOOL / Drilling Tools

ST series

ST series for machining of soft steel, stainless steel

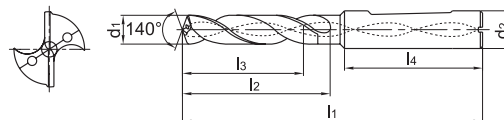
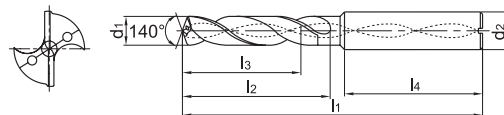

- First choice for drilling soft steel and stainless steel.
- Sharp cutting edge can avoid build-up edge, suitable for drilling hole with high performance.

Drill diameter d ₁ (m7)	Drilling depth (l/d)	Cooling mode	Shank type	Type	Basic dimension(mm)					Recommended grade
					Shank diameter	Overall length	Flute length	Recommended drilling depth	Shank length	
					d ₂ (h6)	l ₁	l ₂	l ₃	l ₄	
3.6	3	Internal coolant	Straight shank	1534ST03C-0360	6	62	20	14	36	☆
	5		Straight shank	1536ST05C-0360	6	66	28	23	36	☆
	5		Whistle notch shank	1736ST05C-0360	6	66	28	23	36	☆
3.7	3		Straight shank	1534ST03C-0370	6	62	20	14	36	☆
	5		Straight shank	1536ST05C-0370	6	66	28	23	36	☆
	5		Whistle notch shank	1736ST05C-0370	6	66	28	23	36	☆
3.8	3		Straight shank	1534ST03C-0380	6	66	24	17	36	☆
	5		Straight shank	1536ST05C-0380	6	74	36	29	36	☆
	5		Whistle notch shank	1736ST05C-0380	6	74	36	29	36	☆
3.9	3		Straight shank	1534ST03C-0390	6	66	24	17	36	☆
	5		Straight shank	1536ST05C-0390	6	74	36	29	36	☆
	5		Whistle notch shank	1736ST05C-0390	6	74	36	29	36	☆
4.0	3		Straight shank	1534ST03C-0400	6	66	24	17	36	☆
	5		Straight shank	1536ST05C-0400	6	74	36	29	36	☆
	5		Whistle notch shank	1736ST05C-0400	6	74	36	29	36	☆
4.1	3		Straight shank	1534ST03C-0410	6	66	24	17	36	☆
	5		Straight shank	1536ST05C-0410	6	74	36	29	36	☆
	5		Whistle notch shank	1736ST05C-0410	6	74	36	29	36	☆
4.2	3	Straight shank	1534ST03C-0420	6	66	24	17	36	☆	
	5	Straight shank	1536ST05C-0420	6	74	36	29	36	☆	
	5	Whistle notch shank	1736ST05C-0420	6	74	36	29	36	☆	
4.3	3	Straight shank	1534ST03C-0430	6	66	24	17	36	☆	
	5	Straight shank	1536ST05C-0430	6	74	36	29	36	☆	
	5	Whistle notch shank	1736ST05C-0430	6	74	36	29	36	☆	
4.4	3	Straight shank	1534ST03C-0440	6	66	24	17	36	☆	
	5	Straight shank	1536ST05C-0440	6	74	36	29	36	☆	
	5	Whistle notch shank	1736ST05C-0440	6	74	36	29	36	☆	
4.5	3	Straight shank	1534ST03C-0450	6	66	24	17	36	☆	
	5	Straight shank	1536ST05C-0450	6	74	36	29	36	☆	
	5	Whistle notch shank	1736ST05C-0450	6	74	36	29	36	☆	

☆ Recommended grade (produce according to order)

Drilling tools

ST series



Drill diameter d ₁ (m7)	Drilling depth (l/d)	Cooling mode	Shank type	Type	Basic dimension(mm)					Recommended grade
					Shank diameter	Overall length	Flute length	Recommended drilling depth	Shank length	
					d ₂ (h6)	l ₁	l ₂	l ₃	l ₄	KDG303
4.6	3	Internal coolant	Straight shank	1534ST03C-0460	6	66	24	17	36	☆
	5			1536ST05C-0460	6	74	36	29	36	☆
	5		Whistle notch shank	1736ST05C-0460	6	74	36	29	36	☆
4.65	3		Straight shank	1534ST03C-0465	6	66	24	17	36	☆
	5			1536ST05C-0465	6	74	36	29	36	☆
	5		Whistle notch shank	1736ST05C-0465	6	74	36	29	36	☆
4.7	3		Straight shank	1534ST03C-0470	6	66	24	17	36	☆
	5			1536ST05C-0470	6	74	36	29	36	☆
	5		Whistle notch shank	1736ST05C-0470	6	74	36	29	36	☆
4.8	3		Straight shank	1534ST03C-0480	6	66	28	20	36	☆
	5			1536ST05C-0480	6	82	44	35	36	☆
	5		Whistle notch shank	1736ST05C-0480	6	82	44	35	36	☆
4.9	3		Straight shank	1534ST03C-0490	6	66	28	20	36	☆
	5			1536ST05C-0490	6	82	44	35	36	☆
	5		Whistle notch shank	1736ST05C-0490	6	82	44	35	36	☆
5.0	3		Straight shank	1534ST03C-0500	6	66	28	20	36	☆
	5			1536ST05C-0500	6	82	44	35	36	☆
	5		Whistle notch shank	1736ST05C-0500	6	82	44	35	36	☆
5.1	3		Straight shank	1534ST03C-0510	6	66	28	20	36	☆
	5			1536ST05C-0510	6	82	44	35	36	☆
	5		Whistle notch shank	1736ST05C-0510	6	82	44	35	36	☆
5.2	3		Straight shank	1534ST03C-0520	6	66	28	20	36	☆
	5			1536ST05C-0520	6	82	44	35	36	☆
	5		Whistle notch shank	1736ST05C-0520	6	82	44	35	36	☆
5.3	3	Straight shank	1534ST03C-0530	6	66	28	20	36	☆	
	5		1536ST05C-0530	6	82	44	35	36	☆	
	5	Whistle notch shank	1736ST05C-0530	6	82	44	35	36	☆	
5.4	3	Straight shank	1534ST03C-0540	6	66	28	20	36	☆	
	5		1536ST05C-0540	6	82	44	35	36	☆	
	5	Whistle notch shank	1736ST05C-0540	6	82	44	35	36	☆	
5.5	3	Straight shank	1534ST03C-0550	6	66	28	20	36	☆	
	5		1536ST05C-0550	6	82	44	35	36	☆	
	5	Whistle notch shank	1736ST05C-0550	6	82	44	35	36	☆	

☆ Recommended grade (produce according to order)

Drilling tools

ST series

➤ Applicable material table

⊙Very suitable ○Suitable

Grade	Workpiece material										
	Mild steel HB≤180	Carbon steel, Alloy steel	Pre-hardened steel, Hardened steel			Stainless steel	Cast iron	Nodular cast iron	Aluminum alloy	Copper alloy	Heat resistant alloy
		~40HRC	~50HRC	~60HRC							
KDG303	⊙	○				⊙					○

Code key

C6

Cutting parameters

C83

Technical information

C87-C93

Non-standard customization tools

C94-C98



BORING TOOL / Drilling Tools

ST series

ST series for machining of soft steel, stainless steel

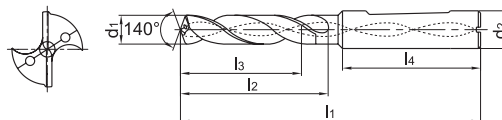
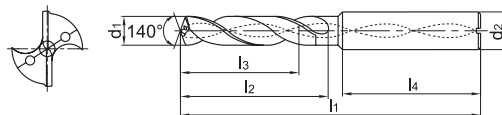

- First choice for drilling soft steel and stainless steel.
- Sharp cutting edge can avoid build-up edge, suitable for drilling hole with high performance.

Drill diameter d ₁ (m7)	Drilling depth (l/d)	Cooling mode	Shank type	Type	Basic dimension(mm)					Recommended grade
					Shank diameter	Overall length	Flute length	Recommended drilling depth	Shank length	
					d ₂ (h6)	l ₁	l ₂	l ₃	l ₄	
5.55	3	Internal coolant	Straight shank	1534ST03C-0555	6	66	28	20	36	☆
	5		Whistle notch shank	1536ST05C-0555	6	82	44	35	36	☆
5.6	5		Straight shank	1736ST05C-0555	6	82	44	35	36	☆
	3		Straight shank	1534ST03C-0560	6	66	28	20	36	☆
	5		Whistle notch shank	1536ST05C-0560	6	82	44	35	36	☆
5.7	5		Straight shank	1736ST05C-0560	6	82	44	35	36	☆
	3		Straight shank	1534ST03C-0570	6	66	28	20	36	☆
	5		Whistle notch shank	1536ST05C-0570	6	82	44	35	36	☆
5.8	5		Straight shank	1736ST05C-0570	6	82	44	35	36	☆
	3		Straight shank	1534ST03C-0580	6	66	28	20	36	☆
	5		Whistle notch shank	1536ST05C-0580	6	82	44	35	36	☆
5.9	5		Straight shank	1736ST05C-0580	6	82	44	35	36	☆
	3		Straight shank	1534ST03C-0590	6	66	28	20	36	☆
	5		Whistle notch shank	1536ST05C-0590	6	82	44	35	36	☆
6.0	5		Straight shank	1736ST05C-0590	6	82	44	35	36	☆
	3		Straight shank	1534ST03C-0600	6	66	28	20	36	☆
	5		Whistle notch shank	1536ST05C-0600	6	82	44	35	36	☆
6.1	5		Straight shank	1736ST05C-0600	6	82	44	35	36	☆
	3	Straight shank	1534ST03C-0610	8	79	34	24	36	☆	
	5	Whistle notch shank	1536ST05C-0610	8	91	53	43	36	☆	
6.2	5	Straight shank	1736ST05C-0610	8	91	53	43	36	☆	
	3	Straight shank	1534ST03C-0620	8	79	34	24	36	☆	
	5	Whistle notch shank	1536ST05C-0620	8	91	53	43	36	☆	
6.3	5	Straight shank	1736ST05C-0620	8	91	53	43	36	☆	
	3	Straight shank	1534ST03C-0630	8	79	34	24	36	☆	
	5	Whistle notch shank	1536ST05C-0630	8	91	53	43	36	☆	
6.4	5	Straight shank	1736ST05C-0630	8	91	53	43	36	☆	
	3	Straight shank	1534ST03C-0640	8	79	34	24	36	☆	
	5	Whistle notch shank	1536ST05C-0640	8	91	53	43	36	☆	

☆ Recommended grade (produce according to order)

Drilling tools

ST series



Drill diameter d ₁ (m7)	Drilling depth (l/d)	Cooling mode	Shank type	Type	Basic dimension(mm)					Recommended grade
					Shank diameter	Overall length	Flute length	Recommended drilling depth	Shank length	
					d ₂ (h6)	l ₁	l ₂	l ₃	l ₄	KDG303
6.5	3	Internal coolant	Straight shank	1534ST03C-0650	8	79	34	24	36	☆
	5			1536ST05C-0650	8	91	53	43	36	☆
6.6	3		Whistle notch shank	1736ST05C-0650	8	91	53	43	36	☆
	5			1534ST03C-0660	8	79	34	24	36	☆
6.7	5		Straight shank	1536ST05C-0660	8	91	53	43	36	☆
	3			1736ST05C-0660	8	91	53	43	36	☆
6.75	5		Whistle notch shank	1534ST03C-0670	8	79	34	24	36	☆
	3			1536ST05C-0670	8	91	53	43	36	☆
6.75	5		Straight shank	1736ST05C-0670	8	91	53	43	36	☆
	3			1534ST03C-0675	8	79	34	24	36	☆
6.9	3		Whistle notch shank	1536ST05C-0675	8	91	53	43	36	☆
	5			1534ST03C-0690	8	79	34	24	36	☆
6.9	5		Straight shank	1536ST05C-0690	8	91	53	43	36	☆
	3			1736ST05C-0690	8	91	53	43	36	☆
7.0	3		Whistle notch shank	1534ST03C-0700	8	79	34	24	36	☆
	5			1536ST05C-0700	8	91	53	43	36	☆
7.0	5		Straight shank	1736ST05C-0700	8	91	53	43	36	☆
	3			1534ST03C-0710	8	79	41	29	36	☆
7.1	5		Whistle notch shank	1536ST05C-0710	8	91	53	43	36	☆
	3			1736ST05C-0710	8	91	53	43	36	☆
7.2	5		Straight shank	1534ST03C-0720	8	79	41	29	36	☆
	3			1536ST05C-0720	8	91	53	43	36	☆
7.2	5		Whistle notch shank	1736ST05C-0720	8	91	53	43	36	☆
	3			1534ST03C-0730	8	79	41	29	36	☆
7.3	5	Straight shank	1536ST05C-0730	8	91	53	43	36	☆	
	3		1736ST05C-0730	8	91	53	43	36	☆	
7.3	5	Whistle notch shank	1534ST03C-0740	8	79	41	29	36	☆	
	3		1536ST05C-0740	8	91	53	43	36	☆	
7.4	5	Straight shank	1736ST05C-0740	8	91	53	43	36	☆	
	3		1534ST03C-0750	8	79	41	29	36	☆	
7.5	5	Whistle notch shank	1536ST05C-0750	8	91	53	43	36	☆	
	3		1736ST05C-0750	8	91	53	43	36	☆	

☆ Recommended grade (produce according to order)

Drilling tools

ST series

➤ Applicable material table

⊙Very suitable ○Suitable

Grade	Workpiece material										
	Mild steel HB≤180	Carbon steel, Alloy steel	Pre-hardened steel, Hardened steel			Stainless steel	Cast iron	Nodular cast iron	Aluminum alloy	Copper alloy	Heat resistant alloy
			~40HRC	~50HRC	~60HRC						
KDG303	⊙	○				⊙					○

Code key

C6

Cutting parameters

C83

Technical information

C87-C93

Non-standard customization tools

C94-C98



ST series

ST series for machining of soft steel, stainless steel

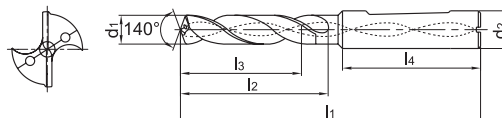
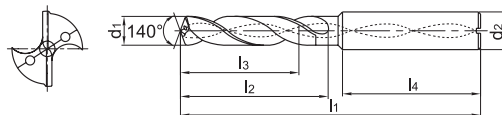

- First choice for drilling soft steel and stainless steel.
- Sharp cutting edge can avoid build-up edge, suitable for drilling hole with high performance.

Drill diameter d ₁ (m7)	Drilling depth (l/d)	Cooling mode	Shank type	Type	Basic dimension(mm)					Recommended grade
					Shank diameter	Overall length	Flute length	Recommended drilling depth	Shank length	
					d ₂ (h6)	l ₁	l ₂	l ₃	l ₄	
7.6	3	Internal coolant	Straight shank	1534ST03C-0760	8	79	41	29	36	☆
	5		Straight shank	1536ST05C-0760	8	91	53	43	36	☆
	5		Whistle notch shank	1736ST05C-0760	8	91	53	43	36	☆
7.7	3		Straight shank	1534ST03C-0770	8	79	41	29	36	☆
	5		Straight shank	1536ST05C-0770	8	91	53	43	36	☆
	5		Whistle notch shank	1736ST05C-0770	8	91	53	43	36	☆
7.8	3		Straight shank	1534ST03C-0780	8	79	41	29	36	☆
	5		Straight shank	1536ST05C-0780	8	91	53	43	36	☆
	5		Whistle notch shank	1736ST05C-0780	8	91	53	43	36	☆
7.9	3		Straight shank	1534ST03C-0790	8	79	41	29	36	☆
	5		Straight shank	1536ST05C-0790	8	91	53	43	36	☆
	5		Whistle notch shank	1736ST05C-0790	8	91	53	43	36	☆
8.0	3		Straight shank	1534ST03C-0800	8	79	41	29	36	☆
	5		Straight shank	1536ST05C-0800	8	91	53	43	36	☆
	5		Whistle notch shank	1736ST05C-0800	8	91	53	43	36	☆
8.1	3	Straight shank	1534ST03C-0810	10	89	47	35	40	☆	
	5	Straight shank	1536ST05C-0810	10	103	61	49	40	☆	
	5	Whistle notch shank	1736ST05C-0810	10	103	61	49	40	☆	
8.2	3	Straight shank	1534ST03C-0820	10	89	47	35	40	☆	
	5	Straight shank	1536ST05C-0820	10	103	61	49	40	☆	
	5	Whistle notch shank	1736ST05C-0820	10	103	61	49	40	☆	
8.3	3	Straight shank	1534ST03C-0830	10	89	47	35	40	☆	
	5	Straight shank	1536ST05C-0830	10	103	61	49	40	☆	
	5	Whistle notch shank	1736ST05C-0830	10	103	61	49	40	☆	
8.4	3	Straight shank	1534ST03C-0840	10	89	47	35	40	☆	
	5	Straight shank	1536ST05C-0840	10	103	61	49	40	☆	
	5	Whistle notch shank	1736ST05C-0840	10	103	61	49	40	☆	
8.5	3	Straight shank	1534ST03C-0850	10	89	47	35	40	☆	
	5	Straight shank	1536ST05C-0850	10	103	61	49	40	☆	
	5	Whistle notch shank	1736ST05C-0850	10	103	61	49	40	☆	

☆ Recommended grade (produce according to order)

Drilling tools

ST series



Drill diameter d ₁ (m7)	Drilling depth (l/d)	Cooling mode	Shank type	Type	Basic dimension(mm)					Recommended grade
					Shank diameter	Overall length	Flute length	Recommended drilling depth	Shank length	
					d ₂ (h6)	l ₁	l ₂	l ₃	l ₄	KDG303
8.6	3	Internal coolant	Straight shank	1534ST03C-0860	10	89	47	35	40	☆
	5			1536ST05C-0860	10	103	61	49	40	☆
	5		Whistle notch shank	1736ST05C-0860	10	103	61	49	40	☆
8.7	3		Straight shank	1534ST03C-0870	10	89	47	35	40	☆
	5			1536ST05C-0870	10	103	61	49	40	☆
	5		Whistle notch shank	1736ST05C-0870	10	103	61	49	40	☆
8.8	3		Straight shank	1534ST03C-0880	10	89	47	35	40	☆
	5			1536ST05C-0880	10	103	61	49	40	☆
	5		Whistle notch shank	1736ST05C-0880	10	103	61	49	40	☆
8.9	3		Straight shank	1534ST03C-0890	10	89	47	35	40	☆
	5			1536ST05C-0890	10	103	61	49	40	☆
	5		Whistle notch shank	1736ST05C-0890	10	103	61	49	40	☆
9.0	3		Straight shank	1534ST03C-0900	10	89	47	35	40	☆
	5			1536ST05C-0900	10	103	61	49	40	☆
	5		Whistle notch shank	1736ST05C-0900	10	103	61	49	40	☆
9.1	3		Straight shank	1534ST03C-0910	10	89	47	35	40	☆
	5			1536ST05C-0910	10	103	61	49	40	☆
	5		Whistle notch shank	1736ST05C-0910	10	103	61	49	40	☆
9.3	3		Straight shank	1534ST03C-0930	10	89	47	35	40	☆
	5			1536ST05C-0930	10	103	61	49	40	☆
	5		Whistle notch shank	1736ST05C-0930	10	103	61	49	40	☆
9.4	3		Straight shank	1534ST03C-0940	10	89	47	35	40	☆
	5			1536ST05C-0940	10	103	61	49	40	☆
	5		Whistle notch shank	1736ST05C-0940	10	103	61	49	40	☆
9.5	3	Straight shank	1534ST03C-0950	10	89	47	35	40	☆	
	5		1536ST05C-0950	10	103	61	49	40	☆	
	5	Whistle notch shank	1736ST05C-0950	10	103	61	49	40	☆	
9.6	3	Straight shank	1534ST03C-0960	10	89	47	35	40	☆	
	5		1536ST05C-0960	10	103	61	49	40	☆	
	5	Whistle notch shank	1736ST05C-0960	10	103	61	49	40	☆	
9.7	3	Straight shank	1534ST03C-0970	10	89	47	35	40	☆	
	5		1536ST05C-0970	10	103	61	49	40	☆	
	5	Whistle notch shank	1736ST05C-0970	10	103	61	49	40	☆	

☆Recommended grade (produce according to order)

Drilling tools

ST series

▶ Applicable material table

⊙Very suitable ○Suitable

Grade	Workpiece material										
	Mild steel HB≤180	Carbon steel, Alloy steel	Pre-hardened steel, Hardened steel			Stainless steel	Cast iron	Nodular cast iron	Aluminum alloy	Copper alloy	Heat resistant alloy
			~40HRC	~50HRC	~60HRC						
KDG303	⊙	○				⊙					○

Code key

C6

Cutting parameters

C83

Technical information

C87-C93

Non-standard customization tools

C94-C98



ST series

ST series for machining of soft steel, stainless steel

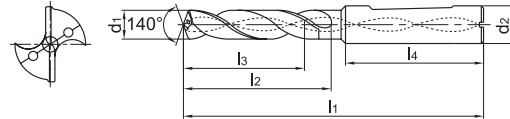
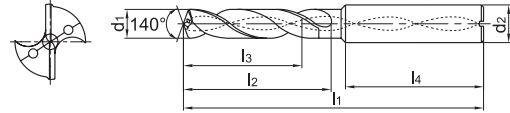

- First choice for drilling soft steel and stainless steel.
- Sharp cutting edge can avoid build-up edge, suitable for drilling hole with high performance.

Drill diameter d ₁ (mm)	Drilling depth l/d	Cooling mode	Shank type	Type	Basic dimension(mm)					Recommended grade
					Shank diameter	Overall length	Flute length	Recommended drilling depth	Shank length	
					d ₂ (h ₆)	l ₁	l ₂	l ₃	l ₄	
9.8	3	Internal coolant	Straight shank	1534ST03C-0980	10	89	47	35	40	☆
	5			1536ST05C-0980	10	103	61	49	40	☆
	5		Whistle notch shank	1736ST05C-0980	10	103	61	49	40	☆
9.9	3		Straight shank	1534ST03C-0990	10	89	47	35	40	☆
	5			1536ST05C-0990	10	103	61	49	40	☆
	5		Whistle notch shank	1736ST05C-0990	10	103	61	49	40	☆
10.0	3		Straight shank	1534ST03C-1000	10	89	47	35	40	☆
	5			1536ST05C-1000	10	103	61	49	40	☆
	5		Whistle notch shank	1736ST05C-1000	10	103	61	49	40	☆
10.1	3		Straight shank	1534ST03C-1010	12	102	55	40	45	☆
	5			1536ST05C-1010	12	118	71	56	45	☆
	5		Whistle notch shank	1736ST05C-1010	12	118	71	56	45	☆
10.25	3		Straight shank	1534ST03C-1025	12	102	55	40	45	☆
	5			1536ST05C-1025	12	118	71	56	45	☆
	5		Whistle notch shank	1736ST05C-1025	12	118	71	56	45	☆
10.3	3		Straight shank	1534ST03C-1030	12	102	55	40	45	☆
	5			1536ST05C-1030	12	118	71	56	45	☆
	5		Whistle notch shank	1736ST05C-1030	12	118	71	56	45	☆
10.4	3	Straight shank	1534ST03C-1040	12	102	55	40	45	☆	
	5		1536ST05C-1040	12	118	71	56	45	☆	
	5	Whistle notch shank	1736ST05C-1040	12	118	71	56	45	☆	
10.5	3	Straight shank	1534ST03C-1050	12	102	55	40	45	☆	
	5		1536ST05C-1050	12	118	71	56	45	☆	
	5	Whistle notch shank	1736ST05C-1050	12	118	71	56	45	☆	
10.6	3	Straight shank	1534ST03C-1060	12	102	55	40	45	☆	
	5		1536ST05C-1060	12	118	71	56	45	☆	
	5	Whistle notch shank	1736ST05C-1060	12	118	71	56	45	☆	
10.7	3	Straight shank	1534ST03C-1070	12	102	55	40	45	☆	
	5		1536ST05C-1070	12	118	71	56	45	☆	
	5	Whistle notch shank	1736ST05C-1070	12	118	71	56	45	☆	

☆ Recommended grade (produce according to order)

Drilling tools

ST series



Drill diameter d ₁ (m7)	Drilling depth (l/d)	Cooling mode	Shank type	Type	Basic dimension(mm)					Recommended grade
					Shank diameter	Overall length	Flute length	Recommended drilling depth	Shank length	KDG303
					d ₂ (h6)	l ₁	l ₂	l ₃	l ₄	
10.8	3	Internal coolant	Straight shank	1534ST03C-1080	12	102	55	40	45	☆
	5			1536ST05C-1080	12	118	71	56	45	☆
	5		Whistle notch shank	1736ST05C-1080	12	118	71	56	45	☆
10.9	3		Straight shank	1534ST03C-1090	12	102	55	40	45	☆
	5			1536ST05C-1090	12	118	71	56	45	☆
	5		Whistle notch shank	1736ST05C-1090	12	118	71	56	45	☆
11.0	3		Straight shank	1534ST03C-1100	12	102	55	40	45	☆
	5			1536ST05C-1100	12	118	71	56	45	☆
	5		Whistle notch shank	1736ST05C-1100	12	118	71	56	45	☆
11.1	3		Straight shank	1534ST03C-1110	12	102	55	40	45	☆
	5			1536ST05C-1110	12	118	71	56	45	☆
	5		Whistle notch shank	1736ST05C-1110	12	118	71	56	45	☆
11.2	3		Straight shank	1534ST03C-1120	12	102	55	40	45	☆
	5			1536ST05C-1120	12	118	71	56	45	☆
	5		Whistle notch shank	1736ST05C-1120	12	118	71	56	45	☆
11.3	3		Straight shank	1534ST03C-1130	12	102	55	40	45	☆
	5			1536ST05C-1130	12	118	71	56	45	☆
	5		Whistle notch shank	1736ST05C-1130	12	118	71	56	45	☆
11.4	3		Straight shank	1534ST03C-1140	12	102	55	40	45	☆
	5			1536ST05C-1140	12	118	71	56	45	☆
	5		Whistle notch shank	1736ST05C-1140	12	118	71	56	45	☆
11.5	3		Straight shank	1534ST03C-1150	12	102	55	40	45	☆
	5			1536ST05C-1150	12	118	71	56	45	☆
	5		Whistle notch shank	1736ST05C-1150	12	118	71	56	45	☆
11.6	3	Straight shank	1534ST03C-1160	12	102	55	40	45	☆	
	5		1536ST05C-1160	12	118	71	56	45	☆	
	5	Whistle notch shank	1736ST05C-1160	12	118	71	56	45	☆	
11.7	3	Straight shank	1534ST03C-1170	12	102	55	40	45	☆	
	5		1536ST05C-1170	12	118	71	56	45	☆	
	5	Whistle notch shank	1736ST05C-1170	12	118	71	56	45	☆	
11.8	3	Straight shank	1534ST03C-1180	12	102	55	40	45	☆	
	5		1536ST05C-1180	12	118	71	56	45	☆	
	5	Whistle notch shank	1736ST05C-1180	12	118	71	56	45	☆	

☆ Recommended grade (produce according to order)

Drilling tools

ST series

➤ Applicable material table

⊙Very suitable ○Suitable

Grade	Workpiece material										
	Mild steel HB≤180	Carbon steel, Alloy steel	Pre-hardened steel, Hardened steel			Stainless steel	Cast iron	Nodular cast iron	Aluminum alloy	Copper alloy	Heat resistant alloy
			~40HRC	~50HRC	~60HRC						
KDG303	⊙	○				⊙					○

Code key

C6

Cutting parameters

C83

Technical information

C87-C93

Non-standard customization tools

C94-C98



ST series

ST series for machining of soft steel, stainless steel

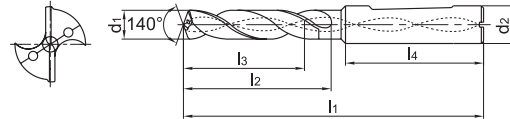
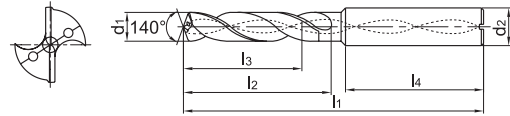

- First choice for drilling soft steel and stainless steel.
- Sharp cutting edge can avoid build-up edge, suitable for drilling hole with high performance.

Drill diameter $d_1(m_7)$	Drilling depth (l/d)	Cooling mode	Shank type	Type	Basic dimension(mm)					Recommended grade
					Shank diameter	Overall length	Flute length	Recommended drilling depth	Shank length	
					$d_2(h_6)$	l_1	l_2	l_3	l_4	
11.9	3	Internal coolant	Straight shank	1534ST03C-1190	12	102	55	40	45	☆
	5		Straight shank	1536ST05C-1190	12	118	71	56	45	☆
	5		Whistle notch shank	1736ST05C-1190	12	118	71	56	45	☆
12.0	3		Straight shank	1534ST03C-1200	12	102	55	40	45	☆
	5		Straight shank	1536ST05C-1200	12	118	71	56	45	☆
	5		Whistle notch shank	1736ST05C-1200	12	118	71	56	45	☆
12.25	3		Straight shank	1534ST03C-1225	14	107	60	43	45	☆
	5		Straight shank	1536ST05C-1225	14	124	77	60	45	☆
	5		Whistle notch shank	1736ST05C-1225	14	124	77	60	45	☆
12.3	3		Straight shank	1534ST03C-1230	14	107	60	43	45	☆
	5		Straight shank	1536ST05C-1230	14	124	77	60	45	☆
	5		Whistle notch shank	1736ST05C-1230	14	124	77	60	45	☆
12.5	3		Straight shank	1534ST03C-1250	14	107	60	43	45	☆
	5		Straight shank	1536ST05C-1250	14	124	77	60	45	☆
	5		Whistle notch shank	1736ST05C-1250	14	124	77	60	45	☆
12.7	3		Straight shank	1534ST03C-1270	14	107	60	43	45	☆
	5		Straight shank	1536ST05C-1270	14	124	77	60	45	☆
	5		Whistle notch shank	1736ST05C-1270	14	124	77	60	45	☆
12.75	3	Straight shank	1534ST03C-1275	14	107	60	43	45	☆	
	5	Straight shank	1536ST05C-1275	14	124	77	60	45	☆	
	5	Whistle notch shank	1736ST05C-1275	14	124	77	60	45	☆	
12.8	3	Straight shank	1534ST03C-1280	14	107	60	43	45	☆	
	5	Straight shank	1536ST05C-1280	14	124	77	60	45	☆	
	5	Whistle notch shank	1736ST05C-1280	14	124	77	60	45	☆	
13.0	3	Straight shank	1534ST03C-1300	14	107	60	43	45	☆	
	5	Straight shank	1536ST05C-1300	14	124	77	60	45	☆	
	5	Whistle notch shank	1736ST05C-1300	14	124	77	60	45	☆	
13.1	3	Straight shank	1534ST03C-1310	14	107	60	43	45	☆	
	5	Straight shank	1536ST05C-1310	14	124	77	60	45	☆	
	5	Whistle notch shank	1736ST05C-1310	14	124	77	60	45	☆	

☆ Recommended grade (produce according to order)

Drilling tools

ST series



Drill diameter d ₁ (m7)	Drilling depth (l/d)	Cooling mode	Shank type	Type	Basic dimension(mm)					Recommended grade
					Shank diameter	Overall length	Flute length	Recommended drilling depth	Shank length	
					d ₂ (h6)	l ₁	l ₂	l ₃	l ₄	KDG303
13.5	3	Internal coolant	Straight shank	1534ST03C-1350	14	107	60	43	45	☆
	5			1536ST05C-1350	14	124	77	60	45	☆
	5		Whistle notch shank	1736ST05C-1350	14	124	77	60	45	☆
13.8	3		Straight shank	1534ST03C-1380	14	107	60	43	45	☆
	5			1536ST05C-1380	14	124	77	60	45	☆
	5		Whistle notch shank	1736ST05C-1380	14	124	77	60	45	☆
14.0	3		Straight shank	1534ST03C-1400	14	107	60	43	45	☆
	5			1536ST05C-1400	14	124	77	60	45	☆
	5		Whistle notch shank	1736ST05C-1400	14	124	77	60	45	☆
14.25	3		Straight shank	1534ST03C-1425	16	115	65	45	48	☆
	5			1536ST05C-1425	16	133	83	63	48	☆
	5		Whistle notch shank	1736ST05C-1425	16	133	83	63	48	☆
14.3	3		Straight shank	1534ST03C-1430	16	115	65	45	48	☆
	5			1536ST05C-1430	16	133	83	63	48	☆
	5		Whistle notch shank	1736ST05C-1430	16	133	83	63	48	☆
14.5	3		Straight shank	1534ST03C-1450	16	115	65	45	48	☆
	5			1536ST05C-1450	16	133	83	63	48	☆
	5		Whistle notch shank	1736ST05C-1450	16	133	83	63	48	☆
14.75	3		Straight shank	1534ST03C-1475	16	115	65	45	48	☆
	5			1536ST05C-1475	16	133	83	63	48	☆
	5		Whistle notch shank	1736ST05C-1475	16	133	83	63	48	☆
14.8	3		Straight shank	1534ST03C-1480	16	115	65	45	48	☆
	5			1536ST05C-1480	16	133	83	63	48	☆
	5		Whistle notch shank	1736ST05C-1480	16	133	83	63	48	☆
15.0	3	Straight shank	1534ST03C-1500	16	115	65	45	48	☆	
	5		1536ST05C-1500	16	133	83	63	48	☆	
	5	Whistle notch shank	1736ST05C-1500	16	133	83	63	48	☆	
15.1	3	Straight shank	1534ST03C-1510	16	115	65	45	48	☆	
	5		1536ST05C-1510	16	133	83	63	48	☆	
	5	Whistle notch shank	1736ST05C-1510	16	133	83	63	48	☆	
15.5	3	Straight shank	1534ST03C-1550	16	115	65	45	48	☆	
	5		1536ST05C-1550	16	133	83	63	48	☆	
	5	Whistle notch shank	1736ST05C-1550	16	133	83	63	48	☆	

☆ Recommended grade (produce according to order)

Drilling tools

ST series

➤ Applicable material table

⊙Very suitable ○Suitable

Grade	Workpiece material										
	Mild steel HB≤180	Carbon steel, Alloy steel	Pre-hardened steel, Hardened steel			Stainless steel	Cast iron	Nodular cast iron	Aluminum alloy	Copper alloy	Heat resistant alloy
			~40HRC	~50HRC	~60HRC						
KDG303	⊙	○				⊙					○

Code key

C6

Cutting parameters

C83

Technical information

C87-C93

Non-standard customization tools

C94-C98



BORING TOOL / Drilling Tools

ST series

ST series for machining of soft steel, stainless steel

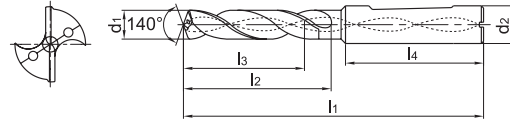
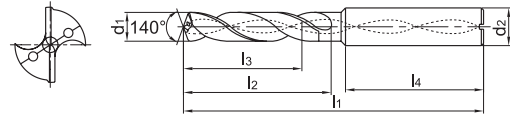

- First choice for drilling soft steel and stainless steel.
- Sharp cutting edge can avoid build-up edge, suitable for drilling hole with high performance.

Drill diameter d ₁ (mm)	Drilling depth (l/d)	Cooling mode	Shank type	Type	Basic dimension(mm)					Recommended grade
					Shank diameter d ₂ (h6)	Overall length l ₁	Flute length l ₂	Recommended drilling depth l ₃	Shank length l ₄	
15.8	3	Internal coolant	Straight shank	1534ST03C-1580	16	115	65	45	48	☆
	5		Straight shank	1536ST05C-1580	16	133	83	63	48	☆
	5		Whistle notch shank	1736ST05C-1580	16	133	83	63	48	☆
16.0	3		Straight shank	1534ST03C-1600	16	115	65	45	48	☆
	5		Straight shank	1536ST05C-1600	16	133	83	63	48	☆
	5		Whistle notch shank	1736ST05C-1600	16	133	83	63	48	☆
16.5	3		Straight shank	1534ST03C-1650	18	123	73	51	48	☆
	5		Straight shank	1536ST05C-1650	18	143	93	71	48	☆
	5		Whistle notch shank	1736ST05C-1650	18	143	93	71	48	☆
16.75	3		Straight shank	1534ST03C-1675	18	123	73	51	48	☆
	5		Straight shank	1536ST05C-1675	18	143	93	71	48	☆
	5		Whistle notch shank	1736ST05C-1675	18	143	93	71	48	☆
16.8	3		Straight shank	1534ST03C-1680	18	123	73	51	48	☆
	5		Straight shank	1536ST05C-1680	18	143	93	71	48	☆
	5		Whistle notch shank	1736ST05C-1680	18	143	93	71	48	☆
17.0	3		Straight shank	1534ST03C-1700	18	123	73	51	48	☆
	5		Straight shank	1536ST05C-1700	18	143	93	71	48	☆
	5		Whistle notch shank	1736ST05C-1700	18	143	93	71	48	☆
17.5	3	Straight shank	1534ST03C-1750	18	123	73	51	48	☆	
	5	Straight shank	1536ST05C-1750	18	143	93	71	48	☆	
	5	Whistle notch shank	1736ST05C-1750	18	143	93	71	48	☆	
17.8	3	Straight shank	1534ST03C-1780	18	123	73	51	48	☆	
	5	Straight shank	1536ST05C-1780	18	143	93	71	48	☆	
	5	Whistle notch shank	1736ST05C-1780	18	143	93	71	48	☆	
18.0	3	Straight shank	1534ST03C-1800	18	123	73	51	48	☆	
	5	Straight shank	1536ST05C-1800	18	143	93	71	48	☆	
	5	Whistle notch shank	1736ST05C-1800	18	143	93	71	48	☆	
18.5	3	Straight shank	1534ST03C-1850	20	131	79	55	50	☆	
	5	Straight shank	1536ST05C-1850	20	153	101	77	50	☆	
	5	Whistle notch shank	1736ST05C-1850	20	153	101	77	50	☆	

☆ Recommended grade (produce according to order)

Drilling tools

ST series



Drill diameter d ₁ (mm)	Drilling depth (l/d)	Cooling mode	Shank type	Type	Basic dimension(mm)					Recommended grade
					Shank diameter	Overall length	Flute length	Recommended drilling depth	Shank length	KDG303
					d ₂ (h ₆)	l ₁	l ₂	l ₃	l ₄	
18.8	3	Internal coolant	Straight shank	1534ST03C-1880	20	131	79	55	50	☆
	5			1536ST05C-1880	20	153	101	77	50	☆
	5		Whistle notch shank	1736ST05C-1880	20	153	101	77	50	☆
19.0	3		Straight shank	1534ST03C-1900	20	131	79	55	50	☆
	5			1536ST05C-1900	20	153	101	77	50	☆
	5		Whistle notch shank	1736ST05C-1900	20	153	101	77	50	☆
19.5	3		Straight shank	1534ST03C-1950	20	131	79	55	50	☆
	5			1536ST05C-1950	20	153	101	77	50	☆
	5		Whistle notch shank	1736ST05C-1950	20	153	101	77	50	☆
19.8	3		Straight shank	1534ST03C-1980	20	131	79	55	50	☆
	5			1536ST05C-1980	20	153	101	77	50	☆
	5		Whistle notch shank	1736ST05C-1980	20	153	101	77	50	☆
20.0	3	Straight shank	1534ST03C-2000	20	131	79	55	50	☆	
	5		1536ST05C-2000	20	153	101	77	50	☆	
	5	Whistle notch shank	1736ST05C-2000	20	153	101	77	50	☆	

☆ Recommended grade (produce according to order)

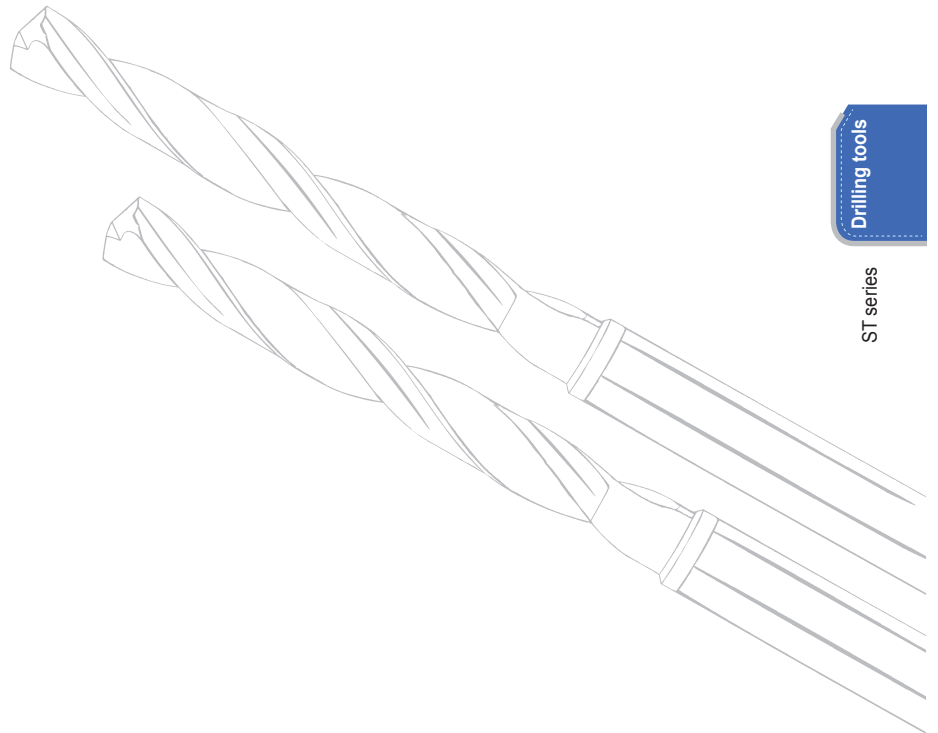

Drilling tools

ST series

▶ Applicable material table

⊙Very suitable ○Suitable

Grade	Workpiece material									
	Mild steel HB≤180	Carbon steel, Alloy steel	Pre-hardened steel, Hardened steel			Stainless steel	Cast iron	Nodular cast iron	Aluminum alloy	Copper alloy
			~40HRC	~50HRC	~60HRC					
KDG303	⊙	○				⊙				○

Code key

C6

Cutting parameters

C83

Technical information

C87-C93

Non-standard customization tools

C94-C98



BORING TOOL

Drilling Tools

SC series

SC series (twist drill) for machining of cast iron, Al alloy



- For materials with short chips such as cast iron, silicon-aluminum alloy, etc.
- Cutting edge and shank with same diameter.

Drill diameter $d_1(h8)$	Drilling depth (l/d)	Cooling mode	Shank type	Type	Basic dimension(mm)			Recommended grade
					Shank diameter	Overall length	Flute length	
					$d_2(h7)$	l_1	l_2	YK20F
2.0	3	External coolant	Straight shank	1105SC03-0200	2.0	38	12	☆
	5			1101SC05-0200	2.0	49	24	☆
2.5	3			1105SC03-0250	2.5	43	14	☆
	5			1101SC05-0250	2.5	57	30	☆
2.8	3			1105SC03-0280	2.8	46	16	☆
	5			1101SC05-0280	2.8	61	33	☆
3.0	3			1105SC03-0300	3.0	46	16	☆
	5			1101SC05-0300	3.0	61	33	☆
3.1	3			1105SC03-0310	3.1	49	18	☆
3.2	3			1105SC03-0320	3.2	49	18	☆
3.3	3			1105SC03-0330	3.3	49	18	☆
3.4	3			1105SC03-0340	3.4	52	20	☆
3.5	3			1105SC03-0350	3.5	52	20	☆
	5			1101SC05-0350	3.5	70	39	☆
3.6	3			1105SC03-0360	3.6	52	20	☆
3.7	3			1105SC03-0370	3.7	52	20	☆
3.8	3			1105SC03-0380	3.8	55	22	☆
	5			1101SC05-0380	3.8	75	43	☆
3.9	3			1105SC03-0390	3.9	55	22	☆
4.0	3			1105SC03-0400	4.0	55	22	☆
	5			1101SC05-0400	4.0	75	43	☆
4.1	3			1105SC03-0410	4.1	55	22	☆
4.2	3			1105SC03-0420	4.2	55	22	☆
	5			1101SC05-0420	4.2	75	43	☆
4.3	3			1105SC03-0430	4.3	58	24	☆
4.4	3			1105SC03-0440	4.4	58	24	☆
4.5	3			1105SC03-0450	4.5	58	24	☆
	5			1101SC05-0450	4.5	80	47	☆
4.6	3	1105SC03-0460	4.6	58	24	☆		
4.7	3	1105SC03-0470	4.7	58	24	☆		
4.8	3	1105SC03-0480	4.8	62	26	☆		
	5	1101SC05-0480	4.8	86	52	☆		

☆ Recommended grade (produce according to order)

Drilling tools

SC series



Drill diameter d ₁ (h ₈)	Drilling depth (l/d)	Cooling mode	Shank type	Type	Basic dimension(mm)			Recommended grade
					Shank diameter	Overall length	Flute length	
					d ₂ (h ₇)	l ₁	l ₂	YK20F
4.9	3	External coolant	Straight shank	1105SC03-0490	4.9	62	26	☆
5.0	3			1105SC03-0500	5.0	62	26	☆
	5			1101SC05-0500	5.0	86	52	☆
5.1	3			1105SC03-0510	5.1	62	26	☆
5.2	3			1105SC03-0520	5.2	62	26	☆
5.3	3			1105SC03-0530	5.3	62	26	☆
5.4	3			1105SC03-0540	5.4	66	28	☆
5.5	3			1105SC03-0550	5.5	66	28	☆
	5			1101SC05-0550	5.5	93	57	☆
5.6	3			1105SC03-0560	5.6	66	28	☆
5.7	3			1105SC03-0570	5.7	66	28	☆
5.8	3			1105SC03-0580	5.8	66	28	☆
	5			1101SC05-0580	5.8	93	57	☆
5.9	3			1105SC03-0590	5.9	66	28	☆
6.0	3			1105SC03-0600	6.0	66	28	☆
	5			1101SC05-0600	6.0	93	57	☆
6.1	3			1105SC03-0610	6.1	70	31	☆
6.2	3			1105SC03-0620	6.2	70	31	☆
6.3	3			1105SC03-0630	6.3	70	31	☆
6.4	3			1105SC03-0640	6.4	70	31	☆
6.5	3			1105SC03-0650	6.5	70	31	☆
	5			1101SC05-0650	6.5	101	63	☆
6.6	3			1105SC03-0660	6.6	70	31	☆
6.7	3			1105SC03-0670	6.7	70	31	☆
6.8	3			1105SC03-0680	6.8	74	34	☆
	5			1101SC05-0680	6.8	109	69	☆
6.9	3			1105SC03-0690	6.9	74	34	☆
7.0	3			1105SC03-0700	7.0	74	34	☆
	5			1101SC05-0700	7.0	109	69	☆
7.1	3			1105SC03-0710	7.1	74	34	☆
7.2	3			1105SC03-0720	7.2	74	34	☆
7.3	3			1105SC03-0730	7.3	74	34	☆
7.4	3			1105SC03-0740	7.4	74	34	☆

☆ Recommended grade (produce according to order)

Drilling tools

SC series

▶▶ Applicable material table

⊙ Very suitable ○ Suitable

Grade	Workpiece material										
	Mild steel HB≤180	Carbon steel, Alloy steel	Pre-hardened steel, Hardened steel			Stainless steel	Cast iron	Nodular cast iron	Aluminum alloy	Copper alloy	Heat resistant alloy
			~40HRC	~50HRC	~60HRC						
YK20F							⊙	○	⊙		

Code key

C6

Cutting parameters

C83

Technical information

C87-C93

Non-standard customization tools

C94-C98



BORING TOOL

Drilling Tools

SC series

SC series (twist drill) for machining of cast iron, Al alloy



External coolant



Straight shank

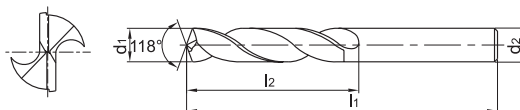

- For materials with short chips such as cast iron, silicon-aluminum alloy, etc.
- Cutting edge and shank with same diameter.

Drill diameter d ₁ (h ₈)	Drilling depth (l/d)	Cooling mode	Shank type	Type	Basic dimension(mm)			Recommended grade
					Shank diameter	Overall length	Flute length	
					d ₂ (h ₇)	l ₁	l ₂	YK20F
7.5	3	External coolant	Straight shank	1105SC03-0750	7.5	74	34	☆
	5			1101SC05-0750	7.5	109	69	☆
7.6	3			1105SC03-0760	7.6	79	37	☆
7.7	3			1105SC03-0770	7.7	79	37	☆
7.8	3			1105SC03-0780	7.8	79	37	☆
	5			1101SC05-0780	7.8	117	75	☆
7.9	3			1105SC03-0790	7.9	79	37	☆
8.0	3			1105SC03-0800	8.0	79	37	☆
	5			1101SC05-0800	8.0	117	75	☆
8.1	3			1105SC03-0810	8.1	79	37	☆
8.2	3			1105SC03-0820	8.2	79	37	☆
8.3	3			1105SC03-0830	8.3	79	37	☆
8.4	3			1105SC03-0840	8.4	79	37	☆
8.5	3			1105SC03-0850	8.5	79	37	☆
	5			1101SC05-0850	8.5	117	75	☆
8.6	3			1105SC03-0860	8.6	84	40	☆
8.7	3			1105SC03-0870	8.7	84	40	☆
8.8	3			1105SC03-0880	8.8	84	40	☆
	5			1101SC05-0880	8.8	125	81	☆
8.9	3			1105SC03-0890	8.9	84	40	☆
9.0	3			1105SC03-0900	9.0	84	40	☆
	5			1101SC05-0900	9.0	125	81	☆
9.1	3			1105SC03-0910	9.1	84	40	☆
9.2	3			1105SC03-0920	9.2	84	40	☆
9.3	3	1105SC03-0930	9.3	84	40	☆		
9.4	3	1105SC03-0940	9.4	84	40	☆		
9.5	3	1105SC03-0950	9.5	84	40	☆		
	5	1101SC05-0950	9.5	125	81	☆		
9.6	3	1105SC03-0960	9.6	89	43	☆		
9.7	3	1105SC03-0970	9.7	89	43	☆		
9.8	3	1105SC03-0980	9.8	89	43	☆		
	5	1101SC05-0980	9.8	133	87	☆		
9.9	3	1105SC03-0990	9.9	89	43	☆		

☆ Recommended grade (produce according to order)

Drilling tools

SC series



Drill diameter d ₁ (h8)	Drilling depth (l/d)	Cooling mode	Shank type	Type	Basic dimension(mm)			Recommended grade
					Shank diameter	Overall length	Flute length	
					d ₂ (h7)	l ₁	l ₂	YK20F
10.0	3	External coolant	Straight shank	1105SC03-1000	10.0	89	43	☆
	5			1101SC05-1000	10.0	133	87	☆
10.1	3			1105SC03-1010	10.1	89	43	☆
10.2	3			1105SC03-1020	10.2	89	43	☆
10.4	3			1105SC03-1040	10.4	89	43	☆
10.5	3			1105SC03-1050	10.5	89	43	☆
	5			1101SC05-1050	10.5	133	87	☆
10.7	3			1105SC03-1070	10.7	95	47	☆
10.8	3			1105SC03-1080	10.8	95	47	☆
	5			1101SC05-1080	10.8	142	94	☆
11.0	3			1105SC03-1100	11.0	95	47	☆
	5			1101SC05-1100	11.0	142	94	☆
11.5	3			1105SC03-1150	11.5	95	47	☆
	5			1101SC05-1150	11.5	142	94	☆
12.0	3			1105SC03-1200	12.0	102	51	☆
	5			1101SC05-1200	12.0	151	101	☆
12.5	3			1105SC03-1250	12.5	102	51	☆
	5			1101SC05-1250	12.5	151	101	☆
12.8	3			1105SC03-1280	12.8	102	51	☆
13.0	3			1105SC03-1300	13.0	102	51	☆
	5			1101SC05-1300	13.0	151	101	☆
13.1	3			1105SC03-1310	13.1	102	51	☆
13.5	3			1105SC03-1350	13.5	107	54	☆
	5			1101SC05-1350	13.5	160	108	☆
14.0	3			1105SC03-1400	14.0	107	54	☆
	5			1101SC05-1400	14.0	160	108	☆
14.3	3			1105SC03-1430	14.3	111	56	☆
14.5	3			1105SC03-1450	14.5	111	56	☆
	5			1101SC05-1450	14.5	169	114	☆
15.0	3			1105SC03-1500	15.0	111	56	☆
	5			1101SC05-1500	15.0	169	114	☆
15.5	5			1101SC05-1550	15.5	178	120	☆
16.0	3			1105SC03-1600	16.0	115	58	☆
	5			1101SC05-1600	16.0	178	120	☆

☆ Recommended grade (produce according to order)

Drilling tools

SC series

▶▶ Applicable material table

⊙ Very suitable ○ Suitable

Grade	Workpiece material										
	Mild steel HB≤180	Carbon steel, Alloy steel	Pre-hardened steel, Hardened steel			Stainless steel	Cast iron	Nodular cast iron	Aluminum alloy	Copper alloy	Heat resistant alloy
			~40HRC	~50HRC	~60HRC						
YK20F							⊙	○	⊙		

Code key

C6

Cutting parameters

C83

Technical information

C87-C93

Non-standard customization tools

C94-C98



BORING TOOL / Drilling Tools

PA series

PA series(three flute drill) for machining of cast iron, AL alloy



External coolant



Straight shank

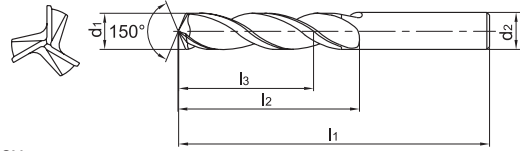

- Suitable for drilling solid workpieces such as cast iron and AL alloy.
- Three-flute construction for high feed rates and excellent centering capability.
- High machining reliability, suitable for harsh working conditions, such as intermittent cutting, etc.

Drill diameter d ₁ (h ₈)	Drilling depth (l/d)	Cooling mode	Shank type	Type	Basic dimension(mm)				Recommended grade		
					Shank diameter	Overall length	Flute length		Recommended drilling depth	KDG303	YK30F
					d ₂ (h ₇)	l ₁	l ₂	l ₃			
3.0	3	External coolant	Straight shank	1165PA03-0300	3.0	46	16	12	☆	☆	
3.1	3			1165PA03-0310	3.1	49	18	14	☆	☆	
3.2	3			1165PA03-0320	3.2	49	18	14	☆	☆	
3.3	3			1165PA03-0330	3.3	49	18	14	☆	☆	
3.4	3			1165PA03-0340	3.4	52	20	15	☆	☆	
3.5	3			1165PA03-0350	3.5	52	20	15	☆	☆	
3.6	3			1165PA03-0360	3.6	52	20	15	☆	☆	
3.7	3			1165PA03-0370	3.7	52	20	15	☆	☆	
3.8	3			1165PA03-0380	3.8	55	22	17	☆	☆	
3.9	3			1165PA03-0390	3.9	55	22	17	☆	☆	
4.0	3			1165PA03-0400	4.0	55	22	17	☆	☆	
4.1	3			1165PA03-0410	4.1	55	22	17	☆	☆	
4.2	3			1165PA03-0420	4.2	55	22	17	☆	☆	
4.3	3			1165PA03-0430	4.3	58	24	18	☆	☆	
4.4	3			1165PA03-0440	4.4	58	24	18	☆	☆	
4.5	3			1165PA03-0450	4.5	58	24	18	☆	☆	
4.6	3			1165PA03-0460	4.6	58	24	18	☆	☆	
4.7	3			1165PA03-0470	4.7	58	24	18	☆	☆	
4.8	3			1165PA03-0480	4.8	62	26	20	☆	☆	
4.9	3			1165PA03-0490	4.9	62	26	20	☆	☆	
5.0	3			1165PA03-0500	5.0	62	26	20	☆	☆	
5.1	3			1165PA03-0510	5.1	62	26	20	☆	☆	
5.2	3			1165PA03-0520	5.2	62	26	20	☆	☆	
5.3	3			1165PA03-0530	5.3	62	26	20	☆	☆	
5.4	3			1165PA03-0540	5.4	66	28	21	☆	☆	
5.5	3			1165PA03-0550	5.5	66	28	21	☆	☆	
5.6	3			1165PA03-0560	5.6	66	28	21	☆	☆	
5.7	3			1165PA03-0570	5.7	66	28	21	☆	☆	
5.8	3	1165PA03-0580	5.8	66	28	21	☆	☆			

☆ Recommended grade (produce according to order)

Drilling tools

PA series



Drill diameter d ₁ (h ₈)	Drilling depth (l/d)	Cooling mode	Shank type	Type	Basic dimension(mm)				Recommended grade	
					Shank diameter	Overall length	Flute length	Recommended drilling depth	KDG303	YK30F
					d ₂ (h ₇)	l ₁	l ₂	l ₃		
5.9	3	External coolant	Straight shank	1165PA03-0590	5.9	66	28	21	☆	☆
6.0	3			1165PA03-0600	6.0	66	28	21	☆	☆
6.1	3			1165PA03-0610	6.1	70	31	23	☆	☆
6.2	3			1165PA03-0620	6.2	70	31	23	☆	☆
6.3	3			1165PA03-0630	6.3	70	31	23	☆	☆
6.4	3			1165PA03-0640	6.4	70	31	23	☆	☆
6.5	3			1165PA03-0650	6.5	70	31	23	☆	☆
6.6	3			1165PA03-0660	6.6	70	31	23	☆	☆
6.7	3			1165PA03-0670	6.7	70	31	23	☆	☆
6.8	3			1165PA03-0680	6.8	74	34	25	☆	☆
6.9	3			1165PA03-0690	6.9	74	34	25	☆	☆
7.0	3			1165PA03-0700	7.0	74	34	25	☆	☆
7.1	3			1165PA03-0710	7.1	74	34	25	☆	☆
7.2	3			1165PA03-0720	7.2	74	34	25	☆	☆
7.3	3			1165PA03-0730	7.3	74	34	25	☆	☆
7.4	3			1165PA03-0740	7.4	74	34	25	☆	☆
7.5	3			1165PA03-0750	7.5	74	34	25	☆	☆
7.6	3			1165PA03-0760	7.6	79	37	27	☆	☆
7.7	3			1165PA03-0770	7.7	79	37	27	☆	☆
7.8	3			1165PA03-0780	7.8	79	37	27	☆	☆
7.9	3			1165PA03-0790	7.9	79	37	27	☆	☆
8.0	3			1165PA03-0800	8.0	79	37	27	☆	☆
8.1	3			1165PA03-0810	8.1	79	37	27	☆	☆
8.2	3			1165PA03-0820	8.2	79	37	27	☆	☆
8.3	3			1165PA03-0830	8.3	79	37	27	☆	☆
8.4	3			1165PA03-0840	8.4	79	37	27	☆	☆
8.5	3			1165PA03-0850	8.5	79	37	27	☆	☆
8.6	3			1165PA03-0860	8.6	84	40	29	☆	☆
8.7	3	1165PA03-0870	8.7	84	40	29	☆	☆		

☆ Recommended grade (produce according to order)

Drilling tools

PA series

▶▶ Applicable material table

⊙ Very suitable ○ Suitable

Grade	Workpiece material										
	Mild steel HB≤180	Carbon steel, Alloy steel	Pre-hardened steel, Hardened steel			Stainless steel	Cast iron	Nodular cast iron	Aluminum alloy	Copper alloy	Heat resistant alloy
			~40HRC	~50HRC	~60HRC						
KDG303						○	⊙	○	⊙	○	
YK30F						○	⊙	○	⊙	○	

Code key

C6

Cutting parameters

C84

Technical information

C87-C93

Non-standard customization tools

C94-C98



BORING TOOL / Drilling Tools

PA series

PA series(three flute drill) for machining of cast iron, AL alloy



External coolant



Straight shank

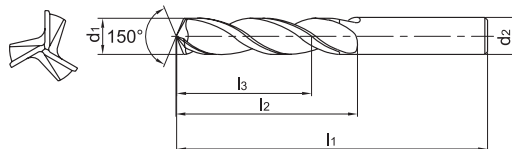

- Suitable for drilling solid workpieces such as cast iron and AL alloy.
- Three-flute construction for high feed rates and excellent centering capability.
- High machining reliability, suitable for harsh working conditions, such as intermittent cutting, etc.

Drill diameter d ₁ (h ₈)	Drilling depth (l/d)	Cooling mode	Shank type	Type	Basic dimension(mm)				Recommended grade		
					Shank diameter	Overall length	Flute length		Recommended drilling depth	KDG303	YK30F
					d ₂ (h ₇)	l ₁	l ₂	l ₃			
8.8	3	External coolant	Straight shank	1165PA03-0880	8.8	84	40	29	☆	☆	
8.9	3			1165PA03-0890	8.9	84	40	29	☆	☆	
9.0	3			1165PA03-0900	9.0	84	40	29	☆	☆	
9.1	3			1165PA03-0910	9.1	84	40	29	☆	☆	
9.2	3			1165PA03-0920	9.2	84	40	29	☆	☆	
9.3	3			1165PA03-0930	9.3	84	40	29	☆	☆	
9.4	3			1165PA03-0940	9.4	84	40	29	☆	☆	
9.5	3			1165PA03-0950	9.5	84	40	29	☆	☆	
9.6	3			1165PA03-0960	9.6	89	43	31	☆	☆	
9.7	3			1165PA03-0970	9.7	89	43	31	☆	☆	
9.8	3			1165PA03-0980	9.8	89	43	31	☆	☆	
9.9	3			1165PA03-0990	9.9	89	43	31	☆	☆	
10.0	3			1165PA03-1000	10.0	89	43	31	☆	☆	
10.1	3			1165PA03-1010	10.1	89	43	31	☆	☆	
10.2	3			1165PA03-1020	10.2	89	43	31	☆	☆	
10.3	3			1165PA03-1030	10.3	89	43	31	☆	☆	
10.5	3			1165PA03-1050	10.5	89	43	31	☆	☆	
11.0	3			1165PA03-1100	11.0	95	47	33	☆	☆	
11.2	3			1165PA03-1120	11.2	95	47	33	☆	☆	
11.5	3			1165PA03-1150	11.5	95	47	33	☆	☆	
11.8	3			1165PA03-1180	11.8	95	47	33	☆	☆	
12.0	3			1165PA03-1200	12.0	102	51	35	☆	☆	
12.1	3			1165PA03-1210	12.1	102	51	35	☆	☆	
12.5	3			1165PA03-1250	12.5	102	51	35	☆	☆	
13.0	3			1165PA03-1300	13.0	102	51	35	☆	☆	
13.5	3			1165PA03-1350	13.5	107	54	37	☆	☆	
14.0	3			1165PA03-1400	14.0	107	54	37	☆	☆	
14.5	3			1165PA03-1450	14.5	111	56	38	☆	☆	
15.0	3			1165PA03-1500	15.0	111	56	38	☆	☆	

☆ Recommended grade (produce according to order)

Drilling tools

PA series



Drill diameter d ₁ (h ₈)	Drilling depth (l/d)	Cooling mode	Shank type	Type	Basic dimension(mm)				Recommended grade	
					Shank diameter	Overall length	Flute length	Recommended drilling depth	KDG303	YK30F
					d ₂ (h ₇)	l ₁	l ₂	l ₃		
15.5	3	External coolant	Straight shank	1165PA03-1550	15.5	115	58	38	☆	☆
16.0	3			1165PA03-1600	16.0	115	58	38	☆	☆
16.5	3			1165PA03-1650	16.5	119	60	39	☆	☆
17.0	3			1165PA03-1700	17.0	119	60	39	☆	☆
17.5	3			1165PA03-1750	17.5	123	62	40	☆	☆
18.0	3			1165PA03-1800	18.0	123	62	40	☆	☆
18.5	3			1165PA03-1850	18.5	127	64	41	☆	☆
19.0	3			1165PA03-1900	19.0	127	64	41	☆	☆
19.5	3			1165PA03-1950	19.5	131	66	42	☆	☆
20.0	3			1165PA03-2000	20.0	131	66	42	☆	☆

☆ Recommended grade (produce according to order)

▶▶ Applicable material table

⊙ Very suitable ○ Suitable

Grade	Workpiece material										
	Mild steel HB≤180	Carbon steel, Alloy steel	Pre-hardened steel, Hardened steel			Stainless steel	Cast iron	Nodular cast iron	Aluminum alloy	Copper alloy	Heat resistant alloy
			~40HRC	~50HRC	~60HRC						
KDG303						○	⊙	○	⊙		○
YK30F						○	⊙	○	⊙		○

Code key
C6

Cutting parameters
C84

Technical information
C87-C93

Non-standard customization tools
C94-C98



BORING TOOL / Drilling Tools

PC series

PC series (straight flute drill) for machining of cast iron, Al alloy

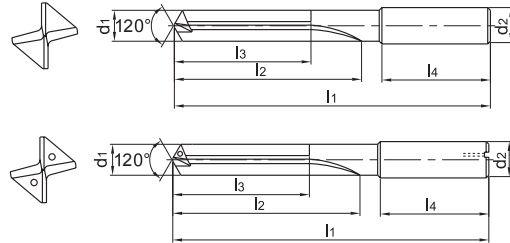

- For materials with short chips such as cast iron, silicon-aluminum alloy, etc.
- Excellent self centering capability, able to machine with high efficiency, the hole precision up to H7.
- High positional accuracy, high linearity and good surface finish can be obtained in the hole drilled.

Drill diameter d ₁ (mm)	Drilling depth (l/d)	Cooling mode	Shank type	Type	Basic dimension(mm)					Recommended grade
					Shank diameter	Overall length	Flute length	Recommended drilling depth	Shank length	
					d ₂ (h ₆)	l ₁	l ₂	l ₃	l ₄	YK20F
4.0	5	External coolant	Straight shank	1576PC05-0400	6.0	74	36	29	36	☆
4.2	5			1576PC05-0420	6.0	74	36	29	36	☆
5.0	5			1576PC05-0500	6.0	82	44	35	36	☆
	15	1579PC15C-0500		6.0	145	105	96	36	☆	
6.0	5	1576PC05-0600		6.0	82	44	35	36	☆	
	15	1579PC15C-0600		6.0	145	105	96	36	☆	
6.75	5	External coolant		1576PC05-0675	8.0	91	53	43	36	☆
7.0	5			1576PC05-0700	8.0	91	53	43	36	☆
8.0	5	Internal coolant		1576PC05-0800	8.0	91	53	43	36	☆
	15			1579PC15C-0800	8.0	180	137	127	36	☆
8.5	5	External coolant		1576PC05-0850	10.0	103	61	49	40	☆
	5			1576PC05-0900	10.0	103	61	49	40	☆
9.0	15	Internal coolant		1579PC15C-0900	10.0	217	170	158	40	☆
	5			1576PC05-1000	10.0	103	61	49	40	☆
10.0	15	Internal coolant		1579PC15C-1000	10.0	217	170	158	40	☆
	5			1576PC05-1025	12.0	118	71	56	45	☆
11.0	5	External coolant		1576PC05-1100	12.0	118	71	56	45	☆
	15			1579PC15C-1100	12.0	258	205	190	45	☆
12.0	5	External coolant		1576PC05-1200	12.0	118	71	56	45	☆
	15			1579PC15C-1200	12.0	258	205	190	45	☆
13.0	5	External coolant	1576PC05-1300	14.0	124	77	60	45	☆	
	5		1576PC05-1400	14.0	124	77	60	45	☆	
14.0	15	Internal coolant	1579PC15C-1400	14.0	290	236	219	45	☆	
	5		1576PC05-1500	16.0	133	83	63	48	☆	
15.0	5	External coolant	1576PC05-1550	16.0	133	83	63	48	☆	
15.5	5		1576PC05-1550	16.0	133	83	63	48	☆	

☆ Recommended grade (produce according to order)

Drilling tools

PC series



Drill diameter d ₁ (m7)	Drilling depth (l/d)	Cooling mode	Shank type	Type	Basic dimension(mm)					Recommended grade
					Shank diameter	Overall length	Flute length	Recommended drilling depth	Shank length	
					d ₂ (h6)	l ₁	l ₂	l ₃	l ₄	YK20F
16.0	5	External coolant	Straight shank	1576PC05-1600	16.0	133	83	63	48	☆
17.0	5			1576PC05-1700	18.0	143	93	71	48	☆
17.5	5			1576PC05-1750	18.0	143	93	71	48	☆
18.0	5			1576PC05-1800	18.0	143	93	71	48	☆
19.5	5			1576PC05-1950	20.0	153	101	77	50	☆
20.0	5			1576PC05-2000	20.0	153	101	77	50	☆

☆ Recommended grade (produce according to order)

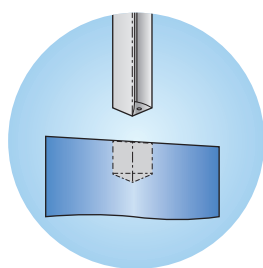

Inclined face drilling

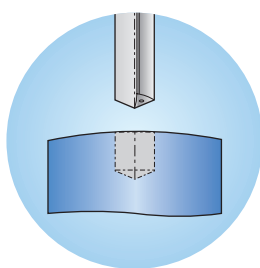

Curved face drilling

When drilling inclined face or curved face, feed rate should be reduced as recommended.

Inclined angle α	Max. feed rate
1°	80%
2°	50%
3°	30%

100% feed rate

Surface with a large inclined angle should be pre-treated. Face milling should be conducted before drilling.

$\alpha > \alpha_{max}$

Drilling tools

PC series

▶ Applicable material table

⊙ Very suitable ○ Suitable

Grade	Workpiece material										
	Mild steel HB≤180	Carbon steel, Alloy steel	Pre-hardened steel, Hardened steel			Stainless steel	Cast iron	Nodular cast iron	Aluminum alloy	Copper alloy	Heat resistant alloy
			~40HRC	~50HRC	~60HRC						
YK20F						⊙	○	⊙			

Code key

C6

Cutting parameters

C85

Technical information

C87-C93

Non-standard customization tools

C94-C98



SC series

SC series(centering drill) for machining of cast iron, AL alloy

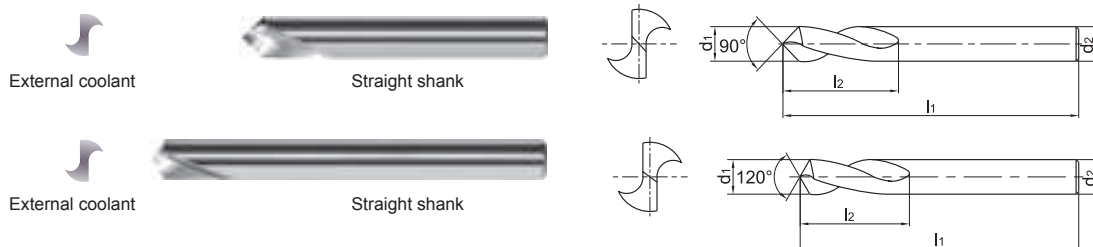

- Suitable for punching center holes and chamfering on CNC machines.
- Compared to conventional center drilling tools, centering drills are more stable and can be easily centered on sloping surfaces.

Drill diameter d ₁ (m7)	Drilling depth (l/d)	Cooling mode	Shank type	Type	Basic dimension(mm)			Recommended grade
					Shank diameter	Overall length	Flute length	
					d ₂ (h ₆)	l ₁	l ₂	YK20F
5	90°	External coolant	Straight shank	1143SC90-0500	5.00	62	10	☆
	120°			1143SC120-0500	5.00	62	10	☆
6	90°			1143SC90-0600	6.00	66	15	☆
	120°			1143SC120-0600	6.00	66	15	☆
8	90°			1143SC90-0800	8.00	79	17	☆
	120°			1143SC120-0800	8.00	79	17	☆
10	90°			1143SC90-1000	10.00	89	20	☆
	120°			1143SC120-1000	10.00	89	20	☆
12	90°			1143SC90-1200	12.00	102	25	☆
	120°			1143SC120-1200	12.00	102	25	☆
14	90°			1143SC90-1400	14.00	107	30	☆
	120°			1143SC120-1400	14.00	107	30	☆
16	90°			1143SC90-1600	16.00	115	35	☆
	120°			1143SC120-1600	16.00	115	35	☆
20	90°			1143SC90-2000	20.00	131	40	☆
	120°			1143SC120-2000	20.00	131	40	☆

☆ Recommended grade (produce according to order)

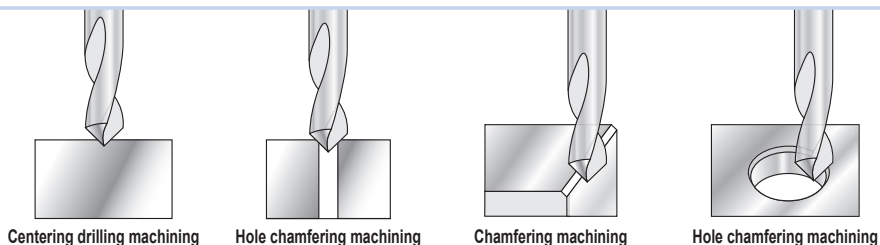

Applicable material table

◎ Very suitable ○ Suitable

Grade	Workpiece material										
	Mild steel HB≤180	Carbon steel, Alloy steel	Pre-hardened steel, Hardened steel			Stainless steel	Cast iron	Nodular cast iron	Aluminum alloy	Copper alloy	Heat resistant alloy
			~40HRC	~50HRC	~60HRC						
YK20F						◎	○	◎			

Code key C6 Cutting parameters C86 Technical information C87-C93 Non-standard customization tools C94-C98



GD series twist drills(external coolant)

3D

5D

workpiece material	Mild steel HB≤180		Carbon steel, alloy steel ~30HRC		Pre-hardened steel ~40HRC		Stainless steel		Cast iron		Nodular cast iron		Heat resistant alloy	
	Cutting speed 60~120m/min		60~120m/min		40~70m/min		25~40m/min		60~120m/min		50~100m/min		15~25m/min	
Diameter (mm)	Rotating speed (min ⁻¹)	Feed rate (mm/r)	Rotating speed (min ⁻¹)	Feed rate (mm/r)	Rotating speed (min ⁻¹)	Feed rate (mm/r)	Rotating speed (min ⁻¹)	Feed rate (mm/r)	Rotating speed (min ⁻¹)	Feed rate (mm/r)	Rotating speed (min ⁻¹)	Feed rate (mm/r)	Rotating speed (min ⁻¹)	Feed rate (mm/r)
2	14000	0.06~0.08	14000	0.06~0.08	9500	0.06~0.08	5500	0.02~0.05	14000	0.06~0.08	11000	0.06~0.08	3200	0.02~0.04
3	9500	0.09~0.12	9500	0.09~0.12	6300	0.09~0.12	3700	0.03~0.07	9500	0.09~0.12	7400	0.09~0.12	2100	0.03~0.06
4	7000	0.10~0.15	7000	0.10~0.15	4700	0.10~0.15	2700	0.04~0.08	7000	0.10~0.15	5600	0.10~0.15	1600	0.04~0.07
5	5700	0.12~0.18	5700	0.12~0.18	3800	0.12~0.18	2200	0.05~0.10	5700	0.12~0.18	4500	0.12~0.18	1250	0.05~0.09
6	4700	0.14~0.20	4700	0.14~0.20	3100	0.14~0.20	1850	0.06~0.12	4700	0.14~0.20	3700	0.14~0.20	1050	0.06~0.11
8	3600	0.16~0.24	3600	0.16~0.24	2400	0.16~0.24	1400	0.08~0.16	3600	0.16~0.24	2800	0.16~0.24	800	0.08~0.14
10	2800	0.18~0.27	2800	0.18~0.27	1900	0.18~0.27	1100	0.10~0.18	2800	0.18~0.27	2200	0.18~0.27	600	0.10~0.16
12	2400	0.20~0.30	2400	0.20~0.30	1600	0.20~0.30	930	0.12~0.20	2400	0.20~0.30	1900	0.20~0.30	500	0.12~0.18
14	2100	0.22~0.35	2100	0.22~0.35	1400	0.22~0.35	800	0.13~0.22	2100	0.22~0.35	1600	0.22~0.35	450	0.13~0.20
16	1800	0.25~0.36	1800	0.25~0.36	1200	0.25~0.36	700	0.14~0.25	1800	0.25~0.36	1400	0.25~0.36	400	0.14~0.23
18	1600	0.28~0.38	1600	0.28~0.38	1100	0.28~0.38	620	0.15~0.28	1600	0.28~0.38	1200	0.28~0.38	350	0.15~0.25
20	1400	0.30~0.40	1400	0.30~0.40	950	0.30~0.40	550	0.16~0.30	1400	0.30~0.40	1100	0.30~0.40	320	0.16~0.28
25	1500	0.32~0.42	1500	0.32~0.42	900	0.32~0.42	700	0.17~0.32	1500	0.32~0.42	1100	0.32~0.42	250	0.17~0.3

1. When the tool is used for the first time, please do a test cutting with 90% of the cutting speed or 85% of the feed rate stated above. As cutting conditions become stable, gradually increase the cutting speed and feed rate.
2. The cutting conditions above are applicable for drilling with emulsion.
3. When clamping drill, please use a collet without any defect or dust, and keep the radial run-out of drill under 0.02mm.
4. These conditions above are applicable for cutting depth under 5D.



BORING TOOL / Drilling Tools

Recommended cutting parameters

GD series twist drills(internal coolant)

3D

5D

workpiece material	Mild steel HB≤180		Carbon steel, alloy steel ~30HRC		Pre-hardened steel ~40HRC		Stainless steel		Cast iron		Nodular cast iron		Heat resistant alloy	
	Rotating speed (min ⁻¹)	Feed rate (mm/r)	Rotating speed (min ⁻¹)	Feed rate (mm/r)	Rotating speed (min ⁻¹)	Feed rate (mm/r)	Rotating speed (min ⁻¹)	Feed rate (mm/r)	Rotating speed (min ⁻¹)	Feed rate (mm/r)	Rotating speed (min ⁻¹)	Feed rate (mm/r)	Rotating speed (min ⁻¹)	Feed rate (mm/r)
Cutting speed	80~150m/min		80~150m/min		50~80m/min		50~80m/min		80~150m/min		60~120m/min		15~25m/min	
Diameter (mm)	12700	0.09~0.12	12700	0.09~0.12	7400	0.09~0.12	6300	0.03~0.07	12700	0.09~0.12	9500	0.09~0.12	2100	0.03~0.06
3	9600	0.10~0.15	9600	0.10~0.15	5600	0.10~0.15	4700	0.04~0.08	9600	0.10~0.15	7000	0.10~0.15	1600	0.04~0.07
4	7600	0.12~0.18	7600	0.12~0.18	4500	0.12~0.18	3800	0.05~0.10	7600	0.12~0.18	5700	0.12~0.18	1250	0.05~0.09
5	6400	0.14~0.20	6400	0.14~0.20	3700	0.14~0.20	3200	0.06~0.12	6400	0.14~0.20	4700	0.14~0.20	1050	0.06~0.11
6	4800	0.16~0.24	4800	0.16~0.24	2800	0.16~0.24	2400	0.08~0.16	4800	0.16~0.24	3600	0.16~0.24	800	0.08~0.14
8	3800	0.18~0.27	3800	0.18~0.27	2200	0.18~0.27	1900	0.10~0.18	3800	0.18~0.27	2800	0.18~0.27	600	0.10~0.16
10	3200	0.20~0.30	3200	0.20~0.30	1900	0.20~0.30	1600	0.12~0.20	3200	0.20~0.30	2400	0.20~0.30	500	0.12~0.18
12	2700	0.22~0.35	2700	0.22~0.35	1600	0.22~0.35	1350	0.13~0.22	2700	0.22~0.35	2100	0.22~0.35	450	0.13~0.20
14	2400	0.25~0.36	2400	0.25~0.36	1400	0.25~0.36	1200	0.14~0.25	2400	0.25~0.36	1800	0.25~0.36	400	0.14~0.23
16	2100	0.28~0.38	2100	0.28~0.38	1200	0.28~0.38	1050	0.15~0.28	2100	0.28~0.38	1600	0.28~0.38	350	0.15~0.25
18	1900	0.30~0.40	1900	0.30~0.40	1100	0.30~0.40	950	0.16~0.30	1900	0.30~0.40	1400	0.30~0.40	320	0.16~0.28
20	1500	0.32~0.42	1500	0.32~0.42	900	0.32~0.42	700	0.17~0.32	1500	0.32~0.42	1100	0.32~0.42	250	0.17~0.3
25														

- When the tool is used for the first time, please do a test cutting with 90% of the cutting speed or 85% of the feed rate stated above. As cutting conditions become stable, gradually increase the cutting speed and feed rate.
- The cutting conditions above are applicable for drilling with emulsion.
- When clamping drill, please use a collet without any defect or dust, and keep the radial run-out of drill under 0.02mm.
- These conditions above are applicable for cutting depth under 5D.

GD series twist drills(internal coolant)

8D

Workpiece material	Mild steel HB≤180		Carbon steel, alloy steel ~30HRC		Pre-hardened steel ~40HRC		Stainless steel		Cast iron		Nodular cast iron		Heat resistant alloy	
	Rotating speed (min ⁻¹)	Feed rate (mm/r)	Rotating speed (min ⁻¹)	Feed rate (mm/r)	Rotating speed (min ⁻¹)	Feed rate (mm/r)	Rotating speed (min ⁻¹)	Feed rate (mm/r)	Rotating speed (min ⁻¹)	Feed rate (mm/r)	Rotating speed (min ⁻¹)	Feed rate (mm/r)	Rotating speed (min ⁻¹)	Feed rate (mm/r)
Cutting speed	80~150m/min		80~150m/min		50~80m/min		40~60m/min		80~150m/min		60~120m/min		15~25m/min	
Diameter (mm)	12700	0.06~0.10	12700	0.06~0.10	7400	0.06~0.10	5300	0.03~0.07	12700	0.06~0.10	9500	0.06~0.10	2100	0.03~0.06
3	9600	0.08~0.12	9600	0.08~0.12	5600	0.08~0.12	4000	0.04~0.08	9600	0.08~0.12	7000	0.08~0.12	1600	0.04~0.07
4	7600	0.10~0.14	7600	0.10~0.14	4500	0.10~0.14	3200	0.05~0.10	7600	0.10~0.14	5700	0.10~0.14	1250	0.05~0.09
5	6400	0.11~0.16	6400	0.11~0.16	3700	0.11~0.16	2700	0.06~0.12	6400	0.11~0.16	4700	0.11~0.16	1050	0.06~0.11
6	4800	0.13~0.19	4800	0.13~0.19	2800	0.13~0.19	2000	0.08~0.16	4800	0.13~0.19	3600	0.13~0.19	800	0.08~0.14
8	3800	0.14~0.22	3800	0.14~0.22	2200	0.14~0.22	1600	0.10~0.18	3800	0.14~0.22	2800	0.14~0.22	600	0.10~0.16
10	3200	0.16~0.24	3200	0.16~0.24	1900	0.16~0.24	1300	0.12~0.20	3200	0.16~0.24	2400	0.16~0.24	500	0.12~0.18
12	2700	0.18~0.28	2700	0.18~0.28	1600	0.18~0.28	1100	0.13~0.22	2700	0.18~0.28	2100	0.18~0.28	450	0.13~0.20
14	2400	0.20~0.29	2400	0.20~0.29	1400	0.20~0.29	1000	0.14~0.25	2400	0.20~0.29	1800	0.20~0.29	400	0.14~0.23
16	2100	0.24~0.32	2100	0.24~0.32	1200	0.24~0.32	880	0.15~0.28	2100	0.24~0.32	1600	0.24~0.32	350	0.15~0.25
18														

- When the tool is used for the first time, please do a test cutting with 90% of the cutting speed or 85% of the feed rate stated above. As cutting conditions become stable, gradually increase the cutting speed and feed rate.
- The cutting conditions above are applicable for drilling with emulsion.
- When clamping drill, please use a collet without any defect or dust, and keep the radial run-out of drill under 0.02mm.
- These conditions above are applicable for cutting depth under 8D.

Drilling tools

Recommended cutting parameters



SL series deep twist drills(internal coolant)

12D

workpiece material	Mild steel HB≤180		Carbon steel, alloy steel ~30HRC		Pre-hardened steel ~40HRC		Stainless steel		Cast iron		Nodular cast iron		Aluminum alloy		Heat resistant alloy	
Cutting speed	60~120m/min		60~120m/min		50~80m/min		40~60m/min		80~150m/min		60~120m/min		100~180m/min		10~20m/min	
Diameter (mm)	Rotating speed (min ⁻¹)	Feed rate (mm/r)	Rotating speed (min ⁻¹)	Feed rate (mm/r)	Rotating speed (min ⁻¹)	Feed rate (mm/r)	Rotating speed (min ⁻¹)	Feed rate (mm/r)	Rotating speed (min ⁻¹)	Feed rate (mm/r)	Rotating speed (min ⁻¹)	Feed rate (mm/r)	Rotating speed (min ⁻¹)	Feed rate (mm/r)	Rotating speed (min ⁻¹)	Feed rate (mm/r)
3	10600	0.06~0.1	10600	0.06~0.1	7400	0.06~0.1	5300	0.03~0.07	12700	0.06~0.1	9500	0.06~0.1	15000	0.09~0.12	2100	0.03~0.06
4	8000	0.08~0.12	8000	0.08~0.12	5600	0.08~0.12	4000	0.04~0.08	96000	0.08~0.12	7000	0.08~0.12	11000	0.10~0.15	1600	0.04~0.07
5	6400	0.10~0.14	6400	0.10~0.14	4500	0.10~0.14	3200	0.05~0.10	7600	0.10~0.14	5700	0.10~0.14	9000	0.10~0.15	1250	0.05~0.9
6	5300	0.11~0.16	5300	0.11~0.16	3700	0.11~0.16	2700	0.06~0.12	6400	0.11~0.16	4700	0.11~0.16	7400	0.11~0.16	1050	0.06~0.11
8	4000	0.13~0.19	4000	0.13~0.19	2800	0.13~0.19	2000	0.08~0.16	4800	0.13~0.19	3600	0.13~0.19	5600	0.13~0.19	800	0.08~0.14
10	3200	0.14~0.22	3200	0.14~0.22	2200	0.14~0.22	1600	0.10~0.18	3800	0.14~0.22	2800	0.14~0.22	4500	0.14~0.22	600	0.10~0.16
12	2700	0.16~0.24	2700	0.16~0.24	1900	0.16~0.24	1300	0.12~0.20	3200	0.16~0.24	2400	0.16~0.24	3700	0.16~0.24	500	0.12~0.18
14	2300	0.18~0.28	2300	0.18~0.28	1600	0.18~0.28	1100	0.13~0.22	2700	0.18~0.28	2100	0.18~0.28	3200	0.18~0.28	450	0.13~0.20
16	2100	0.20~0.30	2100	0.20~0.30	1400	0.20~0.30	1050	0.14~0.25	2100	0.20~0.30	1800	0.20~0.30	2800	0.25~0.36	400	0.14~0.23
18	1800	0.22~0.32	1800	0.22~0.32	1200	0.22~0.32	950	0.15~0.28	1800	0.22~0.32	1600	0.22~0.32	2500	0.28~0.38	350	0.15~0.25
20	1600	0.25~0.35	1600	0.25~0.35	1100	0.25~0.35	800	0.16~0.30	1600	0.25~0.35	1400	0.25~0.35	2300	0.30~0.40	320	0.16~0.28

- When the tool is used for the first time, please do a test cutting with 90% of the cutting speed or 85% of the feed rate stated above. As cutting conditions become stable, gradually increase the cutting speed and feed rate.
- The cutting conditions above are applicable for drilling with emulsion.
- When clamping drill, please use a collet without any defect or dust, and keep the radial run-out of drill under 0.02mm.

SL series deep twist drills(internal coolant)

20D

30D

workpiece material	Mild steel HB≤180		Carbon steel, alloy steel ~30HRC		Pre-hardened steel ~40HRC		Stainless steel		Cast iron		Nodular cast iron		Aluminum alloy		Heat resistant alloy	
Cutting speed	70~90m/min		50~80m/min		40~60m/min		40~60m/min		50~80m/min		60~80m/min		100~180m/min		8~15m/min	
Diameter (mm)	Rotating speed (min ⁻¹)	Feed rate (mm/r)	Rotating speed (min ⁻¹)	Feed rate (mm/r)	Rotating speed (min ⁻¹)	Feed rate (mm/r)	Rotating speed (min ⁻¹)	Feed rate (mm/r)	Rotating speed (min ⁻¹)	Feed rate (mm/r)	Rotating speed (min ⁻¹)	Feed rate (mm/r)	Rotating speed (min ⁻¹)	Feed rate (mm/r)	Rotating speed (min ⁻¹)	Feed rate (mm/r)
3	8250	0.06~0.1	7650	0.06~0.1	5200	0.06~0.1	4750	0.03~0.07	7100	0.06~0.1	7600	0.06~0.1	12750	0.09~0.12	1350	0.03~0.06
4	6250	0.08~0.12	5750	0.08~0.12	3900	0.08~0.12	3600	0.04~0.08	5400	0.08~0.12	5600	0.08~0.12	9350	0.10~0.15	1050	0.04~0.07
5	5000	0.10~0.14	4600	0.10~0.14	3150	0.10~0.14	2900	0.05~0.10	4250	0.10~0.14	4550	0.10~0.14	7650	0.10~0.15	800	0.05~0.09
6	4150	0.11~0.16	3800	0.11~0.16	2600	0.11~0.16	2450	0.06~0.12	3600	0.11~0.16	3750	0.11~0.16	6300	0.11~0.16	700	0.06~0.11
8	3100	0.13~0.19	2900	0.13~0.19	1950	0.13~0.19	1800	0.08~0.16	2700	0.13~0.19	2900	0.13~0.19	4750	0.13~0.19	500	0.08~0.14
10	2500	0.14~0.22	2300	0.14~0.22	1550	0.14~0.22	1450	0.10~0.18	2150	0.14~0.22	2250	0.14~0.22	3850	0.14~0.22	400	0.10~0.16
12	2100	0.16~0.24	1950	0.16~0.24	1350	0.16~0.24	1150	0.12~0.20	1800	0.16~0.24	1900	0.16~0.24	3150	0.16~0.24	350	0.12~0.18~
14	1800	0.18~0.28	1650	0.18~0.28	1100	0.18~0.28	1000	0.13~0.22	1500	0.18~0.28	1700	0.18~0.28	2700	0.18~0.28	300	0.13~0.20

- When the tool is used for the first time, please do a test cutting with 90% of the cutting speed or 85% of the feed rate stated above. As cutting conditions become stable, gradually increase the cutting speed and feed rate.
- The cutting conditions above are applicable for drilling with emulsion.
- When clamping drill, please use a collet without any defect or dust, and keep the radial run-out of drill under 0.02mm.



BORING TOOL / Drilling Tools

Recommended cutting parameters

SP series twist drills(internal coolant)

3D

workpiece material	Mild steel HB≤180		Carbon steel, alloy steel ~30HRC		Pre-hardened steel ~40HRC		Stainless steel		Cast iron		Nodular cast iron		Aluminum alloy		Heat resistant alloy	
Cutting speed	80~150m/min		80~150m/min		50~80m/min		50~80m/min		80~150m/min		60~120m/min		100~180m/min		15~25m/min	
Diameter (mm)	Rotating speed (min ⁻¹)	Feed rate (mm/r)	Rotating speed (min ⁻¹)	Feed rate (mm/r)	Rotating speed (min ⁻¹)	Feed rate (mm/r)	Rotating speed (min ⁻¹)	Feed rate (mm/r)	Rotating speed (min ⁻¹)	Feed rate (mm/r)	Rotating speed (min ⁻¹)	Feed rate (mm/r)	Rotating speed (min ⁻¹)	Feed rate (mm/r)	Rotating speed (min ⁻¹)	Feed rate (mm/r)
3	12700	0.09~ 0.12	12700	0.09~ 0.12	7400	0.09~ 0.12	6300	0.03~ 0.07	12700	0.09~ 0.12	9500	0.09~ 0.12	15000	0.09~ 0.12	2100	0.03~ 0.06
4	9600	0.10~ 0.15	9600	0.10~ 0.15	5600	0.10~ 0.15	4700	0.04~ 0.08	9600	0.10~ 0.15	7000	0.10~ 0.15	11100	0.10~ 0.15	1600	0.04~ 0.07
5	7600	0.12~ 0.18	7600	0.12~ 0.18	4500	0.12~ 0.18	3800	0.05~ 0.10	7600	0.12~ 0.18	5700	0.12~ 0.18	9000	0.12~ 0.18	1250	0.05~ 0.09
6	6400	0.14~ 0.20	6400	0.14~ 0.20	3700	0.14~ 0.20	3200	0.06~ 0.12	6400	0.14~ 0.20	4700	0.14~ 0.20	7400	0.14~ 0.20	1050	0.06~ 0.11
8	4800	0.16~ 0.24	4800	0.16~ 0.24	2800	0.16~ 0.24	2400	0.08~ 0.16	4800	0.16~ 0.24	3600	0.16~ 0.24	5600	0.16~ 0.24	800	0.08~ 0.14
10	3800	0.18~ 0.27	3800	0.18~ 0.27	2200	0.18~ 0.27	1900	0.10~ 0.18	3800	0.18~ 0.27	2800	0.18~ 0.27	4500	0.18~ 0.27	600	0.10~ 0.16
12	3200	0.20~ 0.30	3200	0.20~ 0.30	1900	0.20~ 0.30	1600	0.12~ 0.20	3200	0.20~ 0.30	2400	0.20~ 0.30	3700	0.20~ 0.30	500	0.12~ 0.18
14	2700	0.22~ 0.35	2700	0.22~ 0.35	1600	0.22~ 0.35	1350	0.13~ 0.22	2700	0.22~ 0.35	2100	0.22~ 0.35	3200	0.22~ 0.35	450	0.13~ 0.20

- When the tool is used for the first time, please do a test cutting with 90% of the cutting speed or 85% of the feed rate stated above. As cutting conditions become stable, gradually increase the cutting speed and feed rate.
- The cutting conditions above are applicable for drilling with emulsion.
- When clamping drill, please use a collet without any defect or dust, and keep the radial run-out of drill under 0.02mm.
- These conditions above are applicable for cutting depth under 3D.

Drilling tools

Recommended cutting parameters



ST series twist drills(internal coolant)

3D

5D

Workpiece material	Mild steel HB≤180		Carbon steel, alloy steel ~30HRC		Stainless steel					
	80~150m/min		80~150m/min		Austenite 40~80 m/min		Martensite 50~100 m/min		Ferrite 60~120 m/min	
Cutting speed	80~150m/min		80~150m/min		40~80 m/min		50~100 m/min		60~120 m/min	
Diameter (mm)	Rotating speed (min ⁻¹)	Feed rate (mm/r)	Rotating speed (min ⁻¹)	Feed rate (mm/r)	Rotating speed (min ⁻¹)	Feed rate (mm/r)	Rotating speed (min ⁻¹)	Feed rate (mm/r)	Rotating speed (min ⁻¹)	Feed rate (mm/r)
3	12700	0.09~0.12	12700	0.09~0.12	6300	0.03~0.07	7400	0.03~0.07	9000	0.03~0.07
4	9600	0.10~0.15	9600	0.10~0.15	4700	0.04~0.08	5600	0.04~0.08	6700	0.04~0.08
5	7600	0.12~0.18	7600	0.12~0.18	3800	0.05~0.10	4500	0.05~0.10	5400	0.05~0.10
6	6400	0.14~0.20	6400	0.14~0.20	3200	0.06~0.12	3700	0.06~0.12	4500	0.06~0.12
8	4800	0.16~0.24	4800	0.16~0.24	2400	0.08~0.16	2800	0.08~0.16	3400	0.08~0.16
10	3800	0.18~0.27	3800	0.18~0.27	1900	0.10~0.18	2200	0.10~0.18	2700	0.10~0.18
12	3200	0.20~0.30	3200	0.20~0.30	1600	0.12~0.20	1900	0.12~0.20	2300	0.12~0.20
14	2700	0.22~0.35	2700	0.22~0.35	1350	0.13~0.22	1600	0.13~0.22	1900	0.13~0.22
16	2400	0.25~0.36	2400	0.25~0.36	1200	0.14~0.25	1400	0.14~0.25	1700	0.14~0.25
18	2100	0.28~0.38	2100	0.28~0.38	1050	0.15~0.28	1200	0.15~0.28	1500	0.15~0.28
20	1900	0.30~0.40	1900	0.30~0.40	950	0.16~0.30	1100	0.16~0.30	1350	0.16~0.30

1. When the tool is used for the first time, please do a test cutting with 90% of the cutting speed or 85% of the feed rate stated above. As cutting conditions become stable, gradually increase the cutting speed and feed rate.
2. The cutting conditions above are applicable for drilling with emulsion.
3. When clamping drill, please use a collet without any defect or dust, and keep the radial run-out of drill under 0.02mm.
4. These conditions above are applicable for cutting depth under 5D.

SC series twist drills(external coolant)

3D

5D

Workpiece material	Cast iron		Nodular cast iron		Silicon aluminium alloy				Aluminum alloy	
	50~80m/min		40~70m/min		Si≤10% 100~180m/min		Si>10% 80~140m/min		120~200m/min	
Cutting speed	50~80m/min		40~70m/min		100~180m/min		80~140m/min		120~200m/min	
Diameter (mm)	Rotating speed (min ⁻¹)	Feed rate (mm/r)	Rotating speed (min ⁻¹)	Feed rate (mm/r)	Rotating speed (min ⁻¹)	Feed rate (mm/r)	Rotating speed (min ⁻¹)	Feed rate (mm/r)	Rotating speed (min ⁻¹)	Feed rate (mm/r)
2	9550	0.06~0.08	8000	0.06~0.08	20000	0.07~0.16	18000	0.07~0.16	24000	0.07~0.16
3	6400	0.09~0.12	5300	0.09~0.12	15000	0.09~0.18	12700	0.09~0.18	16000	0.09~0.18
4	4800	0.10~0.15	4000	0.10~0.15	11000	0.10~0.22	9600	0.10~0.22	12000	0.10~0.22
5	3800	0.12~0.18	3200	0.12~0.18	9000	0.12~0.25	7600	0.12~0.25	10000	0.12~0.25
6	3100	0.14~0.20	2700	0.14~0.20	7400	0.14~0.28	6400	0.14~0.28	8500	0.14~0.28
8	2400	0.16~0.24	2000	0.16~0.24	5600	0.18~0.32	4800	0.18~0.32	6400	0.18~0.32
10	1900	0.18~0.27	1600	0.18~0.27	4500	0.22~0.36	3800	0.22~0.36	5000	0.22~0.36
12	1600	0.20~0.30	1300	0.20~0.30	3700	0.25~0.40	3200	0.25~0.40	4200	0.25~0.40
14	1350	0.22~0.35	1150	0.22~0.35	3200	0.27~0.44	2700	0.27~0.44	3600	0.27~0.44
16	1200	0.25~0.36	1000	0.25~0.36	2800	0.32~0.48	2400	0.32~0.48	3200	0.32~0.48

1. When the tool is used for the first time, please do a test cutting with 90% of the cutting speed or 85% of the feed rate stated above. As cutting conditions become stable, gradually increase the cutting speed and feed rate.
2. The cutting conditions above are applicable for drilling with emulsion.
3. When clamping drill, please use a collet without any defect or dust, and keep the radial run-out of drill under 0.02mm.
4. These conditions above are applicable for cutting depth under 5D.

Drilling tools

Recommended cutting parameters



PA series coated 3 flutes drill(external coolant)

3D

Workpiece material	Cast iron		Nodular cast iron		Silicon aluminium alloy				Aluminum alloy		Heat resistant alloy	
	Cutting speed		Cutting speed		Si ≤ 10%		Si > 10%		Cutting speed		Cutting speed	
Diameter (mm)	Rotating speed (min ⁻¹)	Feed rate (mm/r)	Rotating speed (min ⁻¹)	Feed rate (mm/r)	Rotating speed (min ⁻¹)	Feed rate (mm/r)	Rotating speed (min ⁻¹)	Feed rate (mm/r)	Rotating speed (min ⁻¹)	Feed rate (mm/r)	Rotating speed (min ⁻¹)	Feed rate (mm/r)
3	9500	0.09~0.12	7400	0.09~0.12	14000	0.07~0.16	12700	0.07~0.16	16000	0.07~0.16	3200	0.03~0.06
4	7000	0.10~0.15	5600	0.10~0.15	10000	0.09~0.18	9600	0.09~0.18	12000	0.09~0.18	2400	0.04~0.07
5	5700	0.12~0.18	4500	0.12~0.18	9000	0.10~0.22	7600	0.10~0.22	10000	0.10~0.22	1900	0.05~0.09
6	4700	0.14~0.20	3700	0.14~0.20	7400	0.12~0.25	6400	0.12~0.25	8500	0.12~0.25	1600	0.06~0.11
8	3600	0.16~0.24	2800	0.16~0.24	5600	0.14~0.28	4800	0.14~0.28	6400	0.14~0.28	1200	0.08~0.14
10	2800	0.18~0.27	2200	0.18~0.27	4500	0.18~0.32	3800	0.18~0.32	5000	0.18~0.32	950	0.10~0.16
12	2400	0.20~0.30	1900	0.20~0.30	3700	0.22~0.36	3200	0.22~0.36	4200	0.22~0.36	800	0.12~0.18
14	2100	0.22~0.35	1600	0.22~0.35	3200	0.25~0.40	2700	0.25~0.40	3600	0.25~0.40	700	0.13~0.20
16	1800	0.25~0.36	1400	0.25~0.36	2800	0.27~0.44	2400	0.27~0.44	3200	0.27~0.44	600	0.14~0.23
18	1600	0.28~0.38	1200	0.28~0.38	2500	0.32~0.48	2100	0.32~0.48	2800	0.32~0.48	530	0.15~0.25
20	1400	0.30~0.40	1100	0.30~0.40	2300	0.36~0.54	1900	0.36~0.54	2550	0.36~0.54	480	0.16~0.28

- When the tool is used for the first time, please do a test cutting with 90% of the cutting speed or 85% of the feed rate stated above. As cutting conditions become stable, gradually increase the cutting speed and feed rate.
- The cutting conditions above are applicable for drilling with emulsion.
- When clamping drill, please use a collet without any defect or dust, and keep the radial run-out of drill under 0.02mm.
- These conditions above are applicable for cutting depth under 3D.

PA series non-coated 3 flutes drill(external coolant)

3D

Workpiece material	Cast iron		Nodular cast iron		Silicon aluminium alloy				Aluminum alloy		Heat resistant alloy	
	Cutting speed		Cutting speed		Si ≤ 10%		Si > 10%		Cutting speed		Cutting speed	
Diameter (mm)	Rotating speed (min ⁻¹)	Feed rate (mm/r)	Rotating speed (min ⁻¹)	Feed rate (mm/r)	Rotating speed (min ⁻¹)	Feed rate (mm/r)	Rotating speed (min ⁻¹)	Feed rate (mm/r)	Rotating speed (min ⁻¹)	Feed rate (mm/r)	Rotating speed (min ⁻¹)	Feed rate (mm/r)
3	7400	0.09~0.12	5300	0.09~0.12	12700	0.07~0.16	10000	0.07~0.16	15000	0.07~0.16	2100	0.03~0.06
4	5600	0.10~0.15	4000	0.10~0.15	9600	0.09~0.18	8000	0.09~0.18	11000	0.09~0.18	1600	0.04~0.07
5	4500	0.12~0.18	3200	0.12~0.18	7600	0.10~0.22	6300	0.10~0.22	9000	0.10~0.22	1250	0.05~0.09
6	3700	0.14~0.20	2700	0.14~0.20	6400	0.12~0.25	5300	0.12~0.25	7400	0.12~0.25	1050	0.06~0.11
8	2800	0.16~0.24	2000	0.16~0.24	4800	0.14~0.28	4000	0.14~0.28	5600	0.14~0.28	800	0.08~0.14
10	2200	0.18~0.27	1600	0.18~0.27	3800	0.18~0.32	3200	0.18~0.32	4500	0.18~0.32	600	0.10~0.16
12	1900	0.20~0.30	1300	0.20~0.30	3200	0.22~0.36	2700	0.22~0.36	3700	0.22~0.36	500	0.12~0.18
14	1600	0.22~0.35	1100	0.22~0.35	2700	0.25~0.40	2300	0.25~0.40	3200	0.25~0.40	450	0.13~0.20
16	1400	0.25~0.36	1000	0.25~0.36	2400	0.27~0.44	2000	0.27~0.44	2800	0.27~0.44	400	0.14~0.23
18	1200	0.28~0.38	880	0.28~0.38	2100	0.32~0.48	1800	0.32~0.48	2500	0.32~0.48	350	0.15~0.25
20	1100	0.30~0.40	800	0.30~0.40	1900	0.36~0.54	1600	0.36~0.54	2300	0.36~0.54	320	0.16~0.28

- When the tool is used for the first time, please do a test cutting with 90% of the cutting speed or 85% of the feed rate stated above. As cutting conditions become stable, gradually increase the cutting speed and feed rate.
- The cutting conditions above are applicable for drilling with emulsion.
- When clamping drill, please use a collet without any defect or dust, and keep the radial run-out of drill under 0.02mm.
- These conditions above are applicable for cutting depth under 3D.



PC series straight flute drill(external coolant)

5D

Workpiece material	Cast iron		Nodular cast iron		Silicon aluminium alloy				Aluminum alloy	
	Cutting speed		Cutting speed		Si ≤ 10%		Si > 10%		Cutting speed	
Diameter (mm)	Rotating speed (min ⁻¹)	Feed rate (mm/r)	Rotating speed (min ⁻¹)	Feed rate (mm/r)	Rotating speed (min ⁻¹)	Feed rate (mm/r)	Rotating speed (min ⁻¹)	Feed rate (mm/r)	Rotating speed (min ⁻¹)	Feed rate (mm/r)
4	7000	0.10~0.15	5600	0.10~0.15	11000	0.12~0.20	9600	0.12~0.20	12000	0.12~0.20
5	5700	0.12~0.18	4500	0.12~0.18	9000	0.14~0.26	7600	0.14~0.26	10000	0.14~0.26
6	4700	0.14~0.20	3700	0.14~0.20	7400	0.16~0.28	6400	0.16~0.28	8500	0.16~0.28
8	3600	0.16~0.24	2800	0.16~0.24	5500	0.18~0.30	4800	0.18~0.30	6400	0.18~0.30
10	2800	0.18~0.27	2200	0.18~0.27	4500	0.20~0.32	3800	0.20~0.32	5000	0.20~0.32
12	2400	0.20~0.30	1900	0.20~0.30	3700	0.24~0.36	3200	0.24~0.36	4200	0.24~0.36
14	2100	0.22~0.35	1600	0.22~0.35	3200	0.28~0.44	2700	0.28~0.44	3600	0.28~0.44
16	1800	0.25~0.36	1400	0.25~0.36	2800	0.30~0.48	2400	0.30~0.48	3200	0.30~0.48
18	1600	0.28~0.38	1200	0.28~0.38	2500	0.34~0.52	2100	0.34~0.52	3000	0.34~0.52
20	1400	0.30~0.40	1100	0.30~0.40	2300	0.40~0.63	1900	0.40~0.63	2500	0.40~0.63

1. When the tool is used for the first time, please do a test cutting with 90% of the cutting speed or 85% of the feed rate stated above. As cutting conditions become stable, gradually increase the cutting speed and feed rate.
2. The cutting conditions above are applicable for drilling with emulsion.
3. When clamping drill, please use a collet without any defect or dust, and keep the radial run-out of drill under 0.02mm.
4. These conditions above are applicable for cutting depth under 5D.

PC series straight flute drill(internal coolant)

15D

Workpiece material	Cast iron		Nodular cast iron		Silicon aluminium alloy				Aluminum alloy	
	Cutting speed		Cutting speed		Si ≤ 10%		Si > 10%		Cutting speed	
Diameter (mm)	Rotating speed (min ⁻¹)	Feed rate (mm/r)	Rotating speed (min ⁻¹)	Feed rate (mm/r)	Rotating speed (min ⁻¹)	Feed rate (mm/r)	Rotating speed (min ⁻¹)	Feed rate (mm/r)	Rotating speed (min ⁻¹)	Feed rate (mm/r)
5	5700	0.08~0.14	4500	0.08~0.14	9000	0.09~0.18	7600	0.09~0.18	10000	0.09~0.18
6	4700	0.10~0.16	3700	0.10~0.16	7400	0.12~0.20	6400	0.12~0.20	8500	0.12~0.20
8	3600	0.12~0.20	2800	0.12~0.20	5500	0.12~0.24	4800	0.12~0.24	6400	0.12~0.24
10	2800	0.14~0.23	2200	0.14~0.23	4500	0.16~0.28	3800	0.16~0.28	5000	0.16~0.28
12	2400	0.16~0.26	1900	0.16~0.26	3700	0.18~0.32	3200	0.18~0.32	4200	0.18~0.32
14	2100	0.18~0.32	1600	0.18~0.32	3200	0.20~0.36	2700	0.20~0.36	3600	0.20~0.36

1. When the tool is used for the first time, please do a test cutting with 90% of the cutting speed or 85% of the feed rate stated above. As cutting conditions become stable, gradually increase the cutting speed and feed rate.
2. The cutting conditions above are applicable for drilling with emulsion.
3. When clamping drill, please use a collet without any defect or dust, and keep the radial run-out of drill under 0.02mm.
4. These conditions above are applicable for cutting depth under 15D.



BORING TOOL

Drilling Tools

Recommended cutting parameters

SC series centering drill(external coolant)

Centering drilling

Workpiece material	Cast iron		Nodular cast iron		Silicon aluminium alloy				Aluminum alloy	
	60~120m/min		50~100m/min		Si ≤ 10%		Si > 10%		120~200m/min	
Cutting speed	60~120m/min		50~100m/min		100~180m/min		80~140m/min		120~200m/min	
Diameter (mm)	Rotating speed (min ⁻¹)	Feed rate (mm/r)	Rotating speed (min ⁻¹)	Feed rate (mm/r)	Rotating speed (min ⁻¹)	Feed rate (mm/r)	Rotating speed (min ⁻¹)	Feed rate (mm/r)	Rotating speed (min ⁻¹)	Feed rate (mm/r)
5	6400	0.09~0.14	5100	0.09~0.14	9000	0.12~0.25	7600	0.12~0.25	10000	0.12~0.25
6	5300	0.12~0.16	4200	0.12~0.16	7400	0.14~0.28	6400	0.14~0.28	8500	0.14~0.28
8	4000	0.13~0.20	3200	0.13~0.20	5600	0.18~0.32	4800	0.18~0.32	6400	0.18~0.32
10	3200	0.17~0.25	2500	0.17~0.25	4500	0.22~0.36	3800	0.22~0.36	5000	0.22~0.36
12	2700	0.20~0.30	2100	0.20~0.30	3700	0.25~0.40	3200	0.25~0.40	4200	0.25~0.40
14	2400	0.22~0.32	1800	0.22~0.32	3200	0.27~0.44	2700	0.27~0.44	3600	0.27~0.44
16	2000	0.24~0.34	1600	0.24~0.34	2800	0.32~0.48	2400	0.32~0.48	3200	0.32~0.48
20	1600	0.28~0.40	1300	0.28~0.40	2300	0.40~0.60	1900	0.40~0.60	2550	0.40~0.60

1. The cutting datas above are suitable for centering drilling machining.
2. When the tool is used for the first time, please do a test cutting with 90% of the cutting speed or 85% of the feed rate stated above. As cutting conditions become stable, gradually increase the cutting speed and feed rate.
3. The cutting conditions above are applicable for drilling with emulsion.
4. When centering on bevels and toroidal surfaces, please reduce the feed speed.
5. When clamping drill, please use a collet without any defect or dust, and keep the radial run-out of drill under 0.02mm.

Drilling tools

Recommended cutting parameters

Chamfering

Workpiece material	Cast iron		Nodular cast iron		Silicon aluminium alloy				Aluminum alloy	
	90~180m/min		70~150m/min		Si ≤ 10%		Si > 10%		180~300m/min	
Cutting speed	90~180m/min		70~150m/min		150~270m/min		120~210m/min		180~300m/min	
Diameter (mm)	Rotating speed (min ⁻¹)	Feed rate (mm/r)	Rotating speed (min ⁻¹)	Feed rate (mm/r)	Rotating speed (min ⁻¹)	Feed rate (mm/r)	Rotating speed (min ⁻¹)	Feed rate (mm/r)	Rotating speed (min ⁻¹)	Feed rate (mm/r)
5	9600	0.09~0.20	7600	0.09~0.20	13500	0.12~0.30	11500	0.12~0.30	15000	0.12~0.30
6	8000	0.12~0.22	6400	0.12~0.22	11100	0.14~0.34	9600	0.14~0.34	12700	0.14~0.34
8	6000	0.13~0.28	4800	0.13~0.28	8400	0.18~0.40	7200	0.18~0.40	9600	0.18~0.40
10	4800	0.17~0.32	3800	0.17~0.32	6800	0.22~0.44	5700	0.22~0.44	7600	0.22~0.44
12	4000	0.20~0.38	3200	0.20~0.38	5600	0.25~0.50	4800	0.25~0.50	6400	0.25~0.50
14	3600	0.22~0.42	2700	0.22~0.42	4800	0.27~0.56	4000	0.27~0.56	5400	0.27~0.56
16	3000	0.24~0.46	2400	0.24~0.46	4200	0.32~0.60	3600	0.32~0.60	4800	0.32~0.60
20	2400	0.28~0.58	1900	0.28~0.58	3500	0.40~0.76	2850	0.40~0.76	3800	0.40~0.76

1. When the tool is used for the first time, please do a test cutting with 90% of the cutting speed or 85% of the feed rate stated above. As cutting conditions become stable, gradually increase the cutting speed and feed rate.
2. The cutting datas above are suitable for chamfering machining.
3. The cutting conditions above are applicable for drilling with emulsion.
4. When clamping drill, please use a collet without any defect or dust, and keep the radial run-out of drill under 0.02mm.



Application guide of drills

Drill clamping

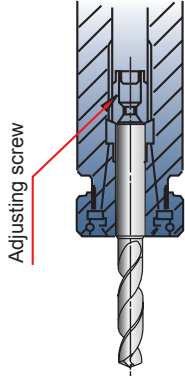

Guarantee tight clamping by using thrust bearing type collet chuck.

How to define the clamping length of drill

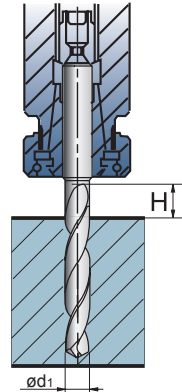

Ensure the size of H is over $1.5d_1$

Radial run-out of drill clamped

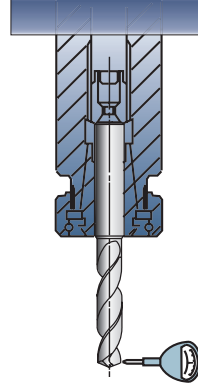

The Radial Run-out should be under 0.02mm.

Wrong drill clamping

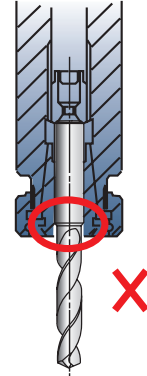

Do not clamp on the drill flutes.

Correct coolant method

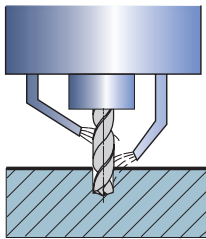

The coolant liquid should be injected to the end and the middle of drill as shown in the figure.

Internal cooling: coolant supply method

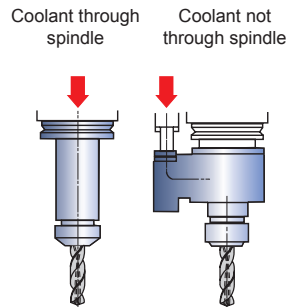

coolant pressure is about 0.5~1MPa (coolant pressure is 2~3MPa when the diameter is less than $\phi 5$ mm)
Coolant volume is 1.5~4L/min.

Cautions on coolant use

When using internal coolant

- ①The little chip particles and dust will cause jamming in the oil hole. A fine mesh filter should be used to prevent such jamming, especially for small-diameter drills.
- ②Dirt and dust particles will adhere to the oil hole and lead to unsmooth coolant flow. Coolant change as early as possible is recommended.

Cautions on interrupted cutting

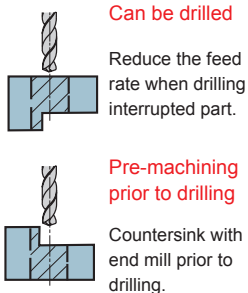

Can be drilled

Reduce the feed rate when drilling interrupted part.

Pre-machining prior to drilling

Countersink with end mill prior to drilling.

Correct method for thin workpiece

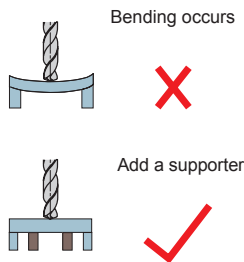

Bending occurs

Add a supporter

Drilling method of stepped holes

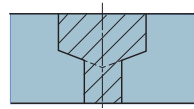

- ①Divided to two drilling processes.
- ②Drill the larger diameter hole firstly.
- ※Multiple step and chamfer drill can be produced by us.

Burrs and workpiece chippings on exit

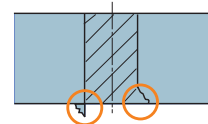

- ①Reduce the feed rate when approaching the exit.
- ②Machine chamfers at the point of exit.
- ③Change the point angle.



Parts terminology of drill

Terminology of drill

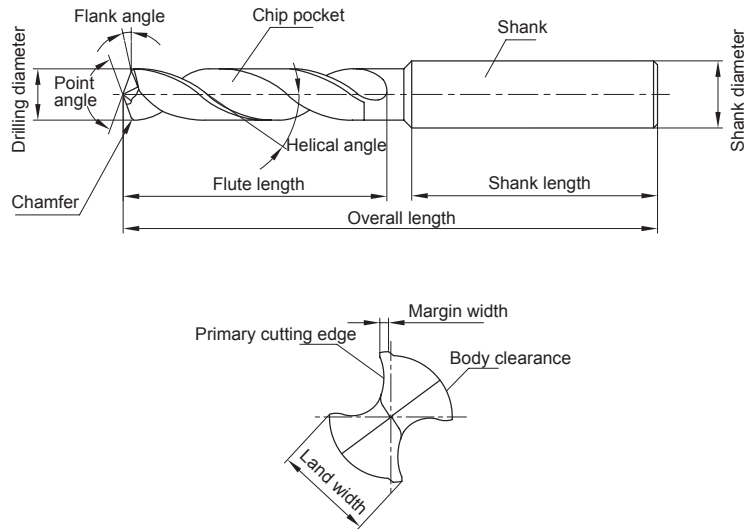

Representative cutting edge shapes

Shape	(Conical)	(Dual face)	(Candler)
Shape			
Features	<ul style="list-style-type: none"> The flank face is conical and the clearance angle increases toward the center of drill. Wide applications, commonly used for both soft and hard materials 	<ul style="list-style-type: none"> Flank face with dual flats to facilitate cutting and initial entering. Often used for small-diameter drills. 	<ul style="list-style-type: none"> Two-stage point angle with perfect centering capability, less burr generated when drilling hole. First choice for drilling thin plate.

Drilling tools

Technical Information



● **Structure specification and cutting characteristics**

Chip pocket	The function of chip pocket is to remove the chips out of the hole. The larger the cross-sectional area is, the easier for chips to be evacuated.			
Helical angle	<p>The helical angle is the inclined angle of flute at the axial direction of a drill. It varies according to the different position of cutting edge. It decreases greatly from the peripheral toward the center.</p> <p style="text-align: center;">High hardness material Small ← Helical angle → Large Soft material</p>			
Flute length	It is determined by depth of hole, guide bushing length and regrinding allowance. The longer the flute is, the lower the drill rigidity is, which greatly affects tool life. So it is recommended to minimize the flute length as much as possible when other requirements are met. The minimal flute length generally is depth of hole plus 1.5 times of the hole diameter.			
Point angle	<p>Generally 118°, set differently as per various applications.</p> <p style="text-align: center;">Soft easy-to-cut material Small ← Point angle → Large for hard materials or high-efficiency machining</p>			
Core	<p>It is an important factor that influence the rigidity and chip control of a drill. It is set according to applications.</p> <table style="width: 100%; border: none;"> <tr> <td style="border: none;"> Low axial cutting force Low rigidity Easy-to-cut materials </td> <td style="border: none; text-align: center; vertical-align: middle;"> thin ← core → Thick </td> <td style="border: none;"> Large axial cutting force High rigidity For machining of high hardness materials, cross hole drilling etc. </td> </tr> </table>	Low axial cutting force Low rigidity Easy-to-cut materials	thin ← core → Thick	Large axial cutting force High rigidity For machining of high hardness materials, cross hole drilling etc.
Low axial cutting force Low rigidity Easy-to-cut materials	thin ← core → Thick	Large axial cutting force High rigidity For machining of high hardness materials, cross hole drilling etc.		
Margin	<p>As a drill guide during drilling process. The margin width need to take the hole friction into consideration.</p> <p style="text-align: center;">Low friction with hole wall, poor guiding performance small ← margin width → large Good guiding performance, high friction with hole wall</p>			
Back taper	In order to decrease the friction with inside wall of the drilled hole, there is a slight back taper from tool nose to shank. The degree is usually represented by the quantity decreasing in the diameter per 100 mm flute length.			
Body clearance	It is the part formed on the clearance face after margin, mainly to reduce the friction between inside wall of hole and drill peripheral.			



Common problems and solutions for drilling

	Problem	Cause	Solution
Hole	Oversize holes 	Poor clamping Large run-out around spindle	Select the holder and chuck with high precision Calibrating spindle Check and adjust after clamping drill
		Non-symmetric point angle Large run-out Chisel edge is off center	Regrind drill Check the precision after regrinding
	Irregular hole size 	Non-symmetric point angle Large run-out Chisel edge is off center Excessive margin abrasion	Select the holder and chuck with high precision Calibrating the spindle Check and adjust after clamping drill
		Poor clamping Large spindle run-out Workpiece is not firmly held	Select the holder and chuck with high precision Calibrating spindle Check and adjust after clamping drill
		Feed rate is too high	Reduce the feed speed
		Coolant provide is not enough	Change the coolant supply method, or increase coolant volume
	Low position accuracy 	Poor re-positioning precision of spindle Poor clamping Large run-out with spindle	Improve the re-positioning precision of machine Select the holder and chuck with high precision Calibrating the spindle Check and adjust after clamping drill
		The feed direction is not vertical to the workpiece surface	Adjust the feed direction vertical to the workpiece
		Top center not align with the spindle center (lathe)	Check and adjust alignment carefully before drilling
	Bad linearity Bad perpendicularity 	Excessive tool abrasion	Regrind
		Poor center hole accuracy	Increase the position accuracy of hole
		Non-symmetric point angle Large run-out Chisel edge is off center	Regrind drill Check the precision after regrinding
Insufficient drill rigidity		Increase drill rigidity	
	Uneven workpiece surface Top center does not align with the spindle center (lathe)	The workpiece must be horizontal or pre-machined to horizontal before drilling Pre-drill a center hole	

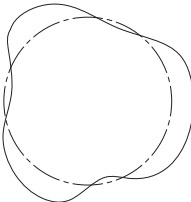
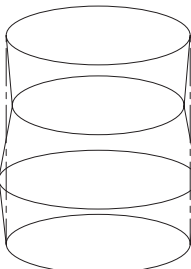

	Problem	Cause	Solution
Hole	<p>Poor roundness</p> 	Non-symmetric point angle Large drill run-out Chisel edge is off center	Regrind drill Check the precision after regrinding
		Poor clamping Large spindle run-out Workpiece is not firmly held	Select the holder and chuck with high precision Calibrating the spindle Check run-out and adjust after clamping drill
		Clearance angle is too large	Regrind drill
		Insufficient drill rigidity	Increase drill rigidity
	<p>Poor workpiece surface quality</p>	Incorrect regrinding	Regrind calibration
		Insufficient coolant or unsuitable coolant type	Change coolant supply method, increase coolant volume Select the cutting oil with good lubricating property
		Poor clamping Large spindle run-out	Select the holder and chuck with high precision Calibrating the spindle
		Feed rate is too high	Decrease the feed rate
		Excessive abrasion on cutting edge Excessive build-up on margin	Regrind drill Select a coated drill
		Chip jamming	Select a suitable drill (considering flute geometry, helical angle etc) Change the cutting method (adjust feed rate, use step feed etc)
	<p>Poor cylindricity</p> 	Non-symmetric point angle Large drill run-out Chisel edge is off center Excessive margin abrasion	Regrind drill Check the precision after regrinding
		Feed speed is too low	Increase the feed speed

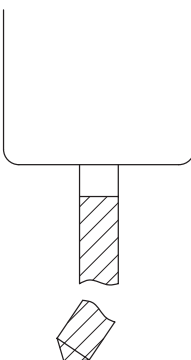
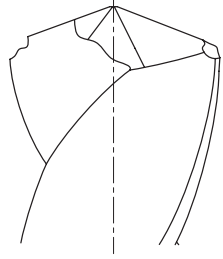
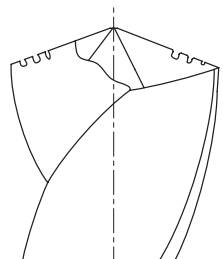

Common problems and solutions for drilling

	Problem	Cause	Solution
Drill	Drill breakage 	Bend ,distortion and slippage of machine and workpiece	Increase the rigidity of drill, machine, workpiece and clamping rigidity
		Clearance angle is too small	Regrind and calibrate
		Feed rate is too high	Decrease the feed rate
		Excessive drill abrasion	Regrind drill
		Chip jamming	Select a suitable drill (considering flute geometry , helical angle etc) Change the cutting method (adjust feed rate, use step feed etc)
		Difficult entering the workpiece	Increase the rigidity of drill and machine Increase rigidity of workpiece and clamping. Select the drill with a sharp point for easy entry Pre-drill a centre hole Adjust the level of workpiece or pre-machined to horizontal before drilling Use guide bushing or bushing plate
	Chipping on the cutting corner 	Unsuitable drill material	Select the suitable drill material
		Hard lump on the workpiece	Analyse the workpiece or select a suitable workpiece Change the cutting parameters(cutting speed , feed rate or machining method)
		Feed rate is too high	Reduce feed rate
		Insufficient coolant	Change coolant supply method, increase coolant volume
	Breakage 	Poor clamping Large spindle run-out	Select the holder and chuck with high precision Calibrating the spindle
		Cutting speed and feed speed are too high	Reduce the cutting speed and feed speed.
		Clearance angle is too large	Regrind and calibrate
		Unsuitable drill material	Select the suitable drill material

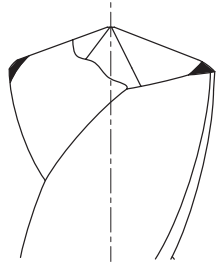

	Problem	Cause	Solution
Drill	Abnormal abrasion on cutting corner 	Regrinding delay	Regrind in time
		Drill point does not align with the spindle center (lathe)	Check and adjust alignment carefully before drilling
		Cutting speed is too high	Reduce cutting speed
		Cutting edge shape is inappropriate	Select appropriate cutting edge shape
		Unsuitable drill material	Select suitable drill material
		Incorrect coolant type	Change coolant
	Abrasion and chipping on chisel edge	Feed speed is too high	Reduce feed speed.
		Cutting edge shape is inappropriate	Select appropriate cutting edge shape
		Unsuitable drill material	Select suitable drill material
		Clearance angle is too small	Regrind drill
	Breakage on margin	The size of guide bushing or drill bushing is too large	Select another bush with correct size
	Margin build-up	Excessive abrasion on cutting edge generates high heat	Regrind drill
		Insufficient coolant	Change coolant supply method, increase coolant volume
		Incorrect coolant type	Change coolant
		Workpiece material is too soft	Change drill or machining method
	High vibration	Clearance angle is too large	Regrind drill
		Drill rigidity is not enough	Increase drill rigidity
	Chips roll around the drill	Long chips Chip removal is not fluent	Change the drill and adjust machining method and cutting parameters
One-side abrasion	Drill point does not align with the spindle center (lathe)	Check and adjust the alignment carefully before drilling	
	Poor clamping	Fix drill carefully, control the radial run-out	



Company name:



Fax:

Huanghe Southern Road, Tianyuan Zone, Zhuzhou. Hunan province

Tel:

Fax: 0731-22882721 22885420 22887878

E-MAIL:

Zip code: 412007 E-mail: zccct@zccct.com

When the diameter specification or length specification on the catalog does not meet your needs, we provide more professional, more precise non-standard customization, you just need to easily choose the series you need.

Diameter Range	External coolant	Ø2.0~Ø20.0mm
	Internal coolant	Ø3.0~Ø20.0mm

Coolant type	
<input type="checkbox"/>	External coolant
<input type="checkbox"/>	Internal coolant

A. Twist drill

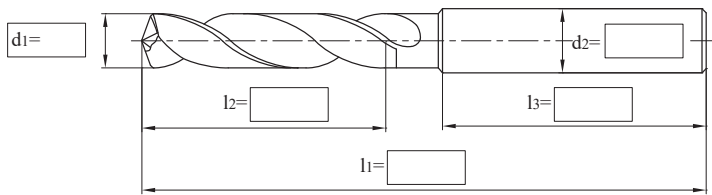

Twist drill bit series selection			
<input type="checkbox"/>	GD series	<input type="checkbox"/>	ST series
<input type="checkbox"/>	SL series	<input type="checkbox"/>	SC series

B. Straight groove drill

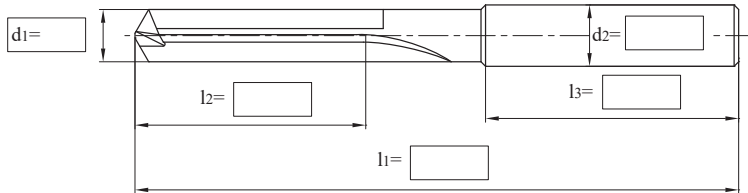

Straight groove drill bit series selection:

PC series

C. Three flute drill

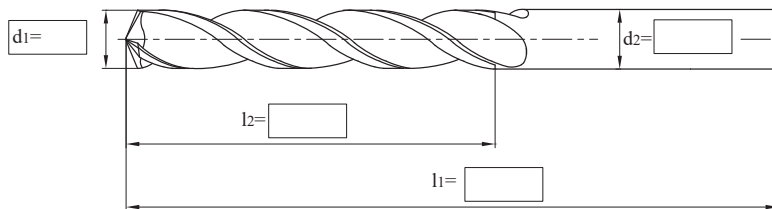

Three flute drill bit series selection:

PA series

Note:

Order Quantity: PCS

Expected delivery date:

Quotation:

Confirmation:

Date:

Drilling tools

Non-standard customization tools



Company name:	
Fax:	Huanghe Southern Road, Tianyuan Zone, Zhuzhou. Hunan province
Tel:	Fax: 0731-22882721 22885420 22887878
E-MAIL:	Zip code: 412007 E-mail: zccct@zccct.com

Hole information and workpiece material

Size of processed hole= <input type="text"/> mm	<input type="checkbox"/> Carbon Steel	<input type="checkbox"/> Grey cast iron	Material grade to be processed: <input type="text"/>
Tolerance of processed hole= <input type="text"/>	<input type="checkbox"/> Alloy Steel	<input type="checkbox"/> Ductile Iron	
Depth of processed hole= <input type="text"/> mm	<input type="checkbox"/> Pre-hardened steel	<input type="checkbox"/> Copper Alloy	Tensile strength= <input type="text"/> N/mm ²
	<input type="checkbox"/> Hardened steel	<input type="checkbox"/> Aluminum alloy	Hardness= <input type="text"/> Units:(HRC, HB, etc.)
	<input type="checkbox"/> Stainless Steel	<input type="checkbox"/> Titanium alloy	
		<input type="checkbox"/> Heat-resistant alloys	

Tool Information

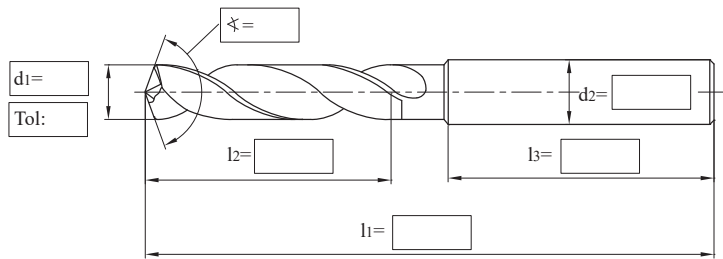

Coolant type	
Internal coolant	<input type="checkbox"/>
External coolant	<input type="checkbox"/>

Coating	
Coated	<input type="checkbox"/>
Non-Coated	<input type="checkbox"/>

Shank form	
<input type="checkbox"/>	Form HA
<input type="checkbox"/>	Form HB
<input type="checkbox"/>	Form HE
<input type="checkbox"/>	Ordinary straight handle
<input type="checkbox"/>	With flat tail handle DIN 1809
<input type="checkbox"/>	Morse Taper Shank MT <input type="checkbox"/>
<input type="checkbox"/>	Special shapes

Note:

Order Quantity:	PCS	Expected delivery date:
Quotation:		Confirmation:
		Date:

Special non-standard tooling customization(twist drill)





Company name:



Fax:

Huanghe Southern Road, Tianyuan Zone,
Zhuzhou. Hunan province

Tel:

Fax: 0731-22882721 22885420 22887878

E-MAIL:

Zip code: 412007 E-mail: zccct@zccct.com

Hole information and workpiece material

Size of processed hole= mm
 Tolerance of processed hole=
 Depth of processed hole= mm

Straight groove drills are widely used for cutting short cutting materials, from cast iron, common aluminum alloys, to high silicon aluminum alloys.

- Grey cast iron
- Ductile Iron
- Aluminum alloy
- Silicon Aluminum Alloy Si<10%
- Silicon Aluminum Alloy Si>10%

Material grade to be processed:

Tensile strength= N/mm²

Hardness= Units:(HRC, HB, etc.)

Tool Information

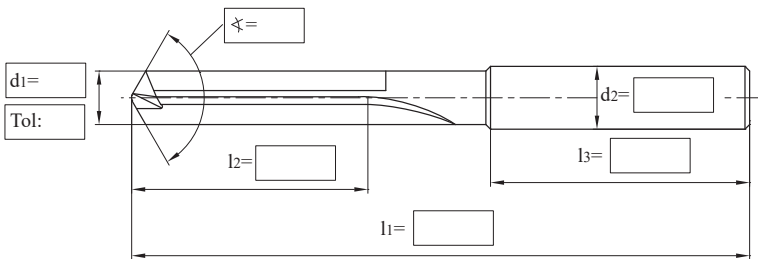

Coolant type	
Internal coolant	<input type="checkbox"/>
External coolant	<input type="checkbox"/>

Coating	
Coated	<input type="checkbox"/>
Non-Coated	<input type="checkbox"/>

DIN6535	Shank form	
	<input type="checkbox"/>	Form HA
	<input type="checkbox"/>	Form HB
	<input type="checkbox"/>	Form HE
	<input type="checkbox"/>	Ordinary straight handle
	<input type="checkbox"/>	With flat tail handle DIN 1809
<input type="checkbox"/>	Morse Taper Shank MT <input type="checkbox"/>	
Special shapes		

Note:

Order Quantity: PCS

Expected delivery date:

Quotation:

Confirmation:

Date:

Drilling tools

Special non-standard tool customization
(stepped straight groove drill)



BORING TOOL / Drilling Tools

Special non-standard tool customization (stepped straight groove drill)

Company name:

Fax:

Tel:

E-MAIL:



Huanghe Southern Road, Tianyuan Zone,
Zhuzhou. Hunan province

Fax: 0731-22882721 22885420 22887878

Zip code: 412007 E-mail: zccct@zccct.com

Hole information and workpiece material

Hole shape to be machined: 

Small hole size= mm

Small hole tolerance=

Large hole size= mm

Large hole tolerance=

Depth of hole to be machined= mm

Straight groove drills are widely used for cutting short cutting materials, from cast iron, common aluminum alloys, to high silicon aluminum alloys.

- Grey cast iron
- Ductile Iron
- Aluminum alloy
- Silicon Aluminum Alloy Si<10%
- Silicon Aluminum Alloy Si≥10%

Material grade to be processed:

Tensile strength= N/mm²

Hardness= Units.(HRC, HB, etc.)

Tool Information

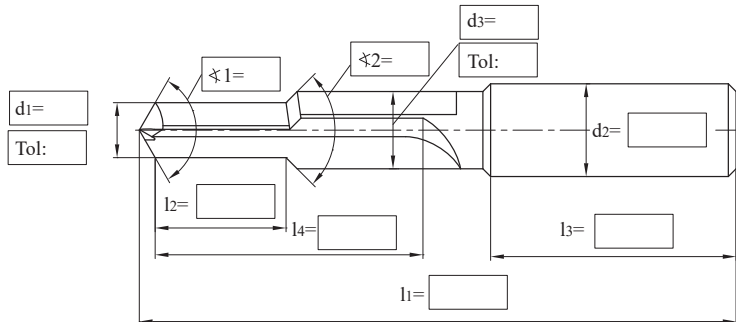

Coolant type	
Internal coolant	<input type="checkbox"/>
External coolant	<input type="checkbox"/>

Coating	
Coated	<input type="checkbox"/>
Non-Coated	<input type="checkbox"/>

Shank form	
<input type="checkbox"/>	Form HA
<input type="checkbox"/>	Form HB
<input type="checkbox"/>	Form HE
<input type="checkbox"/>	Ordinary straight handle
<input type="checkbox"/>	With flat tail handle DIN 1809
<input type="checkbox"/>	Morse Taper Shank MT <input type="checkbox"/>
<input type="checkbox"/>	Special shapes

Note:

Order Quantity: PCS

Expected delivery date:

Quotation:

Confirmation:

Date:

Drilling tools

Special non-standard tool customization (stepped straight groove drill)



How to choose the right U drills

Shape

Product category

Indexable shallow drills

Inserts specification

Including type, dimension, grade and stock.

ZSD02 2D

3D

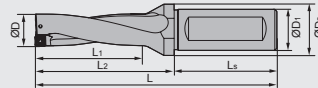

Type	Stock	Basic dimension(mm)							Applicable inserts	Insert screw	Wrench
		ØD	ØD ₁	ØD ₂	L ₁	L ₂	L _s	L			
ZSD02-120-XP20-SP04-02	▲	12.0	20	25	27	44	50	94	SPMX040203-XM/LM/EM/XR	I60M1.8x4	WT05IP
ZSD02-125-XP20-SP04-02	▲	12.5	20	25	28	45	50	95	SPMX040203-XM/LM/EM/XR	I60M1.8x4	WT05IP
ZSD02-130-XP20-SP04-02	▲	13.0	20	25	29	46	50	96	SPMX040203-XM/LM/EM/XR	I60M1.8x4	WT05IP
ZSD02-135-XP20-SP04-02	▲	13.5	20	25	30	47	50	97	SPMX040203-XM/LM/EM/XR	I60M1.8x4	WT05IP
ZSD02-140-XP20-SP04-02	▲	14.0	20	25	31	48	50	98	SPMX040203-XM/LM/EM/XR	I60M1.8x4	WT05IP
ZSD02-145-XP20-SP04-02	▲	14.5	20	25	32	49	50	99	SPMX040203-XM/LM/EM/XR	I60M1.8x4	WT05IP
ZSD02-150-XP20-SP05-02	▲	15.0	20	25	33	50	50	100	SPMX050204-XM/LM/EM/XR	I60M2x4.3	WT06P
ZSD02-155-XP20-SP05-02	▲	15.5	20	25	34	51	50	101	SPMX050204-XM/LM/EM/XR	I60M2x4.3	WT06P
ZSD02-160-XP20-SP05-02	▲	16.0	20	25	35	52	50	102	SPMX050204-XM/LM/EM/XR	I60M2x4.3	WT06P
ZSD02-165-XP20-SP05-02	▲	16.5	20	25	36	53	50	103	SPMX050204-XM/LM/EM/XR	I60M2x4.3	WT06P
ZSD02-170-XP20-SP05-02	▲	17.0	20	25	37	54	50	104	SPMX050204-XM/LM/EM/XR	I60M2x4.3	WT06P
ZSD02-175-XP20-SP05-02	▲	17.5	20	25	38	55	50	105	SPMX050204-XM/LM/EM/XR	I60M2x4.3	WT06P
ZSD02-180-XP25-SP06-02	▲	18.0	25	32	39	57	56	113	SPMX060204-XM/LM/EM/XR	I60M2.2x5.5	WT07IP
ZSD02-185-XP25-SP06-02	▲	18.5	25	32	40	58	56	114	SPMX060204-XM/LM/EM/XR	I60M2.2x5.5	WT07IP
ZSD02-190-XP25-SP06-02	▲	19.0	25	32	41	59	56	115	SPMX060204-XM/LM/EM/XR	I60M2.2x5.5	WT07IP
ZSD02-195-XP25-SP06-02	▲	19.5	25	32	42	60	56	116	SPMX060204-XM/LM/EM/XR	I60M2.2x5.5	WT07IP
ZSD02-200-XP25-SP06-02	▲	20.0	25	32	43	61	56	117	SPMX060204-XM/LM/EM/XR	I60M2.2x5.5	WT07IP
ZSD02-205-XP25-SP06-02	▲	20.5	25	32	44	62	56	118	SPMX060204-XM/LM/EM/XR	I60M2.2x5.5	WT07IP

▲ Stock available △ Make-to-order

ZSD applicable inserts

-EM

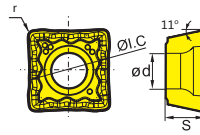

Type	Basic dimension(mm)				CVD grade			PVD grade	
	Ø1.C	s	ød	r	YB6338(Peripheral edge)	YBM215(Inner/peripheral edge)	YBS203(Inner/peripheral edge)	YB9320(Inner/peripheral edge)	
SPMX040203-EM	4.0	2.38	2.2	0.3	★	●	●	★	
SPMX050204-EM	5.0	2.38	2.2	0.4	★	●	●	★	
SPMX060204-EM	6.0	2.38	2.5	0.4	★	●	●	★	
SPMX07T308-EM	7.94	3.97	2.8	0.8	★	●	●	★	
SPMX090408-EM	9.8	4.3	4.1	0.8	★	●	●	★	
SPMX110408-EM	11.5	4.76	4.4	0.8	★	●	●	★	
SPMX140512-EM	14.3	5.2	5.5	1.2	★	●	●	★	

★ Recommended grade (always stock available) ● Available grade (always stock available) ○ Make-to-order

Shape

Product category

Inserts specification

Including type, dimension, grade and stock.



BORING TOOL / Drilling Tools

U drills code key

U drills code key

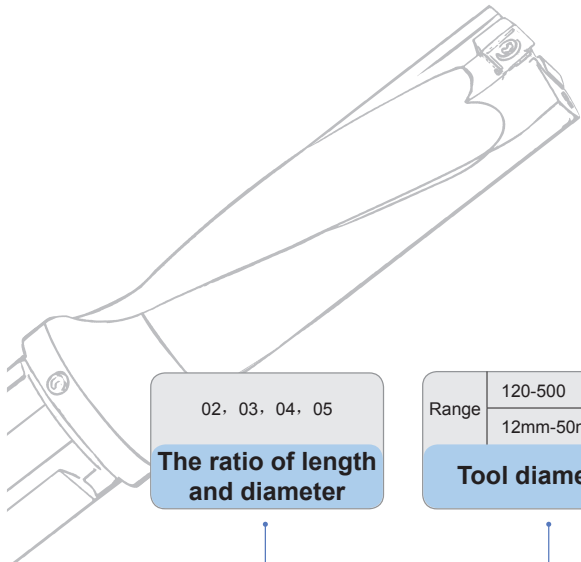

02, 03, 04, 05

The ratio of length and diameter

Range

120-500
12mm-50mm

Tool diameter

W



S



Insert shape

C

7°

P

11°

Insert clearance angle

Code	Edge length	
	W	S
03	3.8	
04	4.3	
05	5.4	5.0
06	6.5	6.0
07		7.94
08	8.7	
09		9.8
11		11.5

Cutting edge length(mm)

ZSD 02 - 120 - XP 20 - S P 04 - 02

Drilling tools

U drills code key

Tool type

Code	Description
ZTD	Double helical inner coolant indexable shallow drill
ZSD	Indexable shallow drill

Coupling structure and type

Code	Description
XP	Weldon shank

Coupling size(mm)

20, 25, 32, 40

Number of tooth

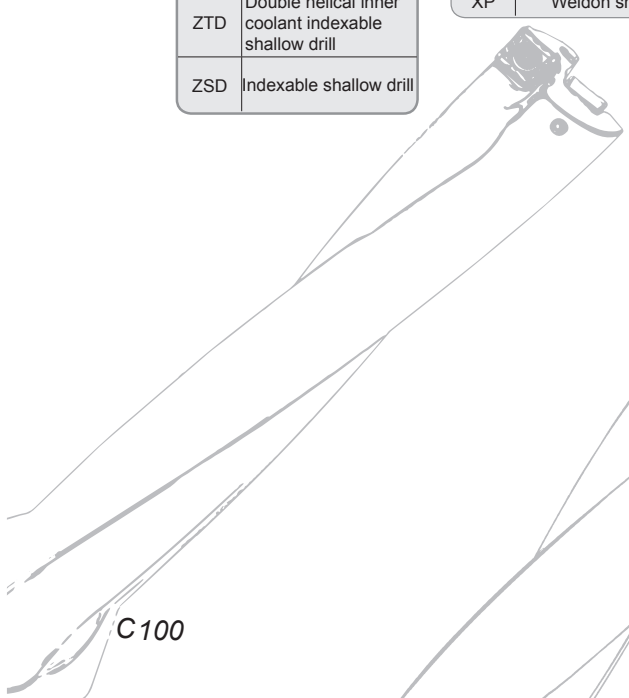

C100

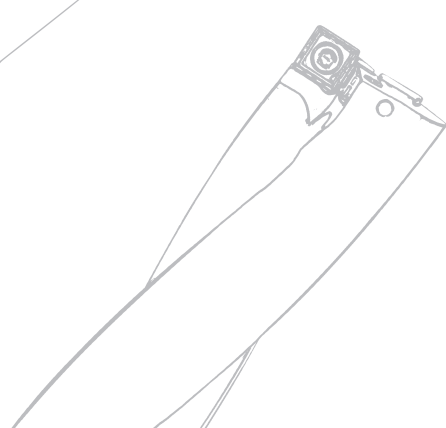

High Efficiency Indexable Drill

ZSD series



- Unique waved-edge geometry structure produces steady cutting and smooth chip evacuation;
- Insert designed for double balanced radial run-out control for achieving high accuracy and precision even in long overhang applications;
- Wiper technology produces excellent surface quality and diameter dimension consistency;
- Strong impact-resistance and highly rigid design structure helps achieve high speed, high efficiency, and high stability machining;
- Economical four-edges insert, design suitable for Deep-hole drilling in 2D~5D.



▲ -EM

Geometry for soft steels to prevent chip-wrapping.

▲ -XM

General-purpose geometry for stable machining operations.

▲ -LM

Geometry for Stainless steel and sticky chip materials.

▲ -XR

Machining of hard materials, strengthen cutting edges.

There are three types of geometry, suitable for high efficiency and stability machining in multiple materials.

Case study

Workpiece material: 45[#]steel (HB170-220)

Tool: ZSD05-160-XP20-SP05-02

Insert: SPMX050204-XM/YB9320

Cutting data: Vc=120m/min, f=0.07mm/r,
ap=80mm

Cooling: Internal coolant supply

• Aperture cylindricity



ZCC-CT



Similar products of company A

Cylindricity	0.03mm	0.15mm
ZCC-CT	0.03mm	0.15mm
Similar products of company A	0.03mm	0.15mm

• Hole surface quality

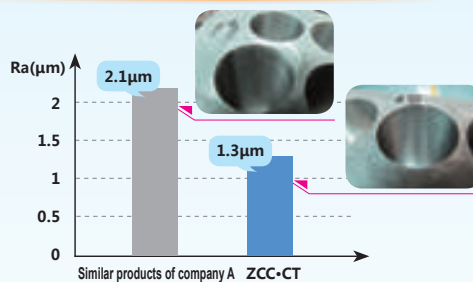

Conclusion: under the same working conditions, the machined hole surface quality by ZSD series indexable insert drill contributes to better hole precision than A company's similar products.



CVD coating grade

YB6338 (peripheral inserts)

- ▶ Substrate of a tough gradient cemented carbide, enriched with surface bonding phase, nano-dioxygen gradient transition layer, and crystal core pre-implantation coating technology, improves the inserts' wear and heat resistance.
- ▶ Suitable for high-speed, high-feed, and stable working conditions, it is the first choice for drilling of steel.

PVD coating grade

YB9315 (peripheral/central inserts)

• Multilayer nano-coating PVD grade

- ▶ Significantly enhanced on wear resistance & heat resistance, adopting the gradient transition technology, effectively improvement on stress and interface states of the coating layers. Reducing stress concentration, increase the strengths between coating layer and substrate, improve the cutting tool's stability, suitable for M materials drilling machining.

YBS203 (peripheral/central inserts)

• High performance grade for S materials

- ▶ Alloy toughness enhancement technology improves the tool's resistance to crack propagation and high temperature oxidation while ensuring high wear resistance.
- ▶ Adopting a new hard alloy matrix formula greatly improves the high-temperature performance and extends tool life.

YB9320 (peripheral/central inserts)

• General purpose for drilling in P, M, K, N materials

- ▶ The atomic rearrangement technology realizes the long-range orderly arrangement of different coating materials to achieve a perfect match between hardness and toughness, effectively solving the problem of high temperature instability at the interface of multiple coatings and improving the high temperature performance of the coating.
- ▶ High-toughness substrate and TiAlN-based nano multilayer coating, unique ion etching technology, strengthen the cutting edge, and improve the bonding strength between the coating and the substrate.
- ▶ Advanced surface treatment technology, optimized stress distribution, better overall performance.



U drills

ZSD02 2D

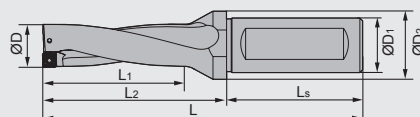

Type	Stock	Basic dimension(mm)							Applicable inserts	Insert screw	Wrench
		ØD	ØD ₁	ØD ₂	L ₁	L ₂	L _s	L			
ZSD02-120-XP20-SP04-02	▲	12.0	20	25	27	44	50	94	SPMX040203-XM/LM/EM/XR	I60M1.8×4.5	WT05IP
ZSD02-125-XP20-SP04-02	▲	12.5	20	25	28	45	50	95	SPMX040203-XM/LM/EM/XR	I60M1.8×4.5	WT05IP
ZSD02-130-XP20-SP04-02	▲	13.0	20	25	29	46	50	96	SPMX040203-XM/LM/EM/XR	I60M1.8×4.5	WT05IP
ZSD02-135-XP20-SP04-02	▲	13.5	20	25	30	47	50	97	SPMX040203-XM/LM/EM/XR	I60M1.8×4.5	WT05IP
ZSD02-140-XP20-SP04-02	▲	14.0	20	25	31	48	50	98	SPMX040203-XM/LM/EM/XR	I60M1.8×4.5	WT05IP
ZSD02-145-XP20-SP04-02	▲	14.5	20	25	32	49	50	99	SPMX040203-XM/LM/EM/XR	I60M1.8×4.5	WT05IP
ZSD02-150-XP20-SP05-02	▲	15.0	20	25	33	50	50	100	SPMX050204-XM/LM/EM/XR	I60M2×4.3	WT06P
ZSD02-155-XP20-SP05-02	▲	15.5	20	25	34	51	50	101	SPMX050204-XM/LM/EM/XR	I60M2×4.3	WT06P
ZSD02-160-XP20-SP05-02	▲	16.0	20	25	35	52	50	102	SPMX050204-XM/LM/EM/XR	I60M2×4.3	WT06P
ZSD02-165-XP20-SP05-02	▲	16.5	20	25	36	53	50	103	SPMX050204-XM/LM/EM/XR	I60M2×4.3	WT06P
ZSD02-170-XP20-SP05-02	▲	17.0	20	25	37	54	50	104	SPMX050204-XM/LM/EM/XR	I60M2×4.3	WT06P
ZSD02-175-XP20-SP05-02	▲	17.5	20	25	38	55	50	105	SPMX050204-XM/LM/EM/XR	I60M2×4.3	WT06P
ZSD02-180-XP25-SP06-02	▲	18.0	25	32	39	57	56	113	SPMX060204-XM/LM/EM/XR	I60M2.2×5.5	WT07IP
ZSD02-185-XP25-SP06-02	▲	18.5	25	32	40	58	56	114	SPMX060204-XM/LM/EM/XR	I60M2.2×5.5	WT07IP
ZSD02-190-XP25-SP06-02	▲	19.0	25	32	41	59	56	115	SPMX060204-XM/LM/EM/XR	I60M2.2×5.5	WT07IP
ZSD02-195-XP25-SP06-02	▲	19.5	25	32	42	60	56	116	SPMX060204-XM/LM/EM/XR	I60M2.2×5.5	WT07IP
ZSD02-200-XP25-SP06-02	▲	20.0	25	32	43	61	56	117	SPMX060204-XM/LM/EM/XR	I60M2.2×5.5	WT07IP
ZSD02-205-XP25-SP06-02	▲	20.5	25	32	44	62	56	118	SPMX060204-XM/LM/EM/XR	I60M2.2×5.5	WT07IP
ZSD02-210-XP25-SP06-02	▲	21.0	25	32	45	63	56	119	SPMX060204-XM/LM/EM/XR	I60M2.2×5.5	WT07IP
ZSD02-215-XP25-SP06-02	▲	21.5	25	32	46	64	56	120	SPMX060204-XM/LM/EM/XR	I60M2.2×5.5	WT07IP
ZSD02-220-XP25-SP06-02	▲	22.0	25	32	47	65	56	121	SPMX060204-XM/LM/EM/XR	I60M2.2×5.5	WT07IP
ZSD02-225-XP25-SP07-02	▲	22.5	25	32	48	66	56	122	SPMX07T308-XM/LM/EM/XR	I60M2.5×6.5	WT07IP
ZSD02-230-XP25-SP07-02	▲	23.0	25	32	49	67	56	123	SPMX07T308-XM/LM/EM/XR	I60M2.5×6.5	WT07IP
ZSD02-235-XP25-SP07-02	▲	23.5	25	32	50	68	56	124	SPMX07T308-XM/LM/EM/XR	I60M2.5×6.5	WT07IP
ZSD02-240-XP25-SP07-02	▲	24.0	25	32	51	69	56	125	SPMX07T308-XM/LM/EM/XR	I60M2.5×6.5	WT07IP
ZSD02-245-XP25-SP07-02	▲	24.5	25	32	52	70	56	126	SPMX07T308-XM/LM/EM/XR	I60M2.5×6.5	WT07IP
ZSD02-250-XP25-SP07-02	▲	25.0	25	32	53	71	56	127	SPMX07T308-XM/LM/EM/XR	I60M2.5×6.5	WT07IP
ZSD02-255-XP25-SP07-02	▲	25.5	25	32	54	72	56	128	SPMX07T308-XM/LM/EM/XR	I60M2.5×6.5	WT07IP
ZSD02-260-XP25-SP07-02	▲	26.0	25	32	55	73	56	129	SPMX07T308-XM/LM/EM/XR	I60M2.5×6.5	WT07IP
ZSD02-265-XP25-SP07-02	▲	26.5	25	32	56	74	56	130	SPMX07T308-XM/LM/EM/XR	I60M2.5×6.5	WT07IP
ZSD02-270-XP25-SP07-02	▲	27.0	25	32	57	75	56	131	SPMX07T308-XM/LM/EM/XR	I60M2.5×6.5	WT07IP

▲ Stock available △ Make-to-order

Drilling tools

U drills



U drills

U drills

ZSD02 2D

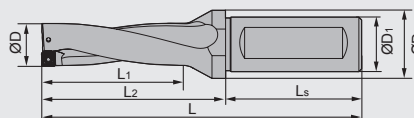



Type	Stock	Basic dimension(mm)							Applicable inserts	Insert screw	Wrench
		ØD	ØD ₁	ØD ₂	L ₁	L ₂	L _s	L			
ZSD02-275-XP25-SP07-02	▲	27.5	25	32	58	76	56	132	SPMX07T308- XM/LM/EM/XR	I60M2.5×6.5	WT07IP
ZSD02-280-XP32-SP09-02	▲	28.0	32	37	59	79	60	139	SPMX090408- XM/LM/EM/XR	I60M3.5×8	WT15IP
ZSD02-285-XP32-SP09-02	▲	28.5	32	37	60	80	60	140	SPMX090408- XM/LM/EM/XR	I60M3.5×8	WT15IP
ZSD02-290-XP32-SP09-02	▲	29.0	32	37	61	81	60	141	SPMX090408- XM/LM/EM/XR	I60M3.5×8	WT15IP
ZSD02-295-XP32-SP09-02	▲	29.5	32	37	62	82	60	142	SPMX090408- XM/LM/EM/XR	I60M3.5×8	WT15IP
ZSD02-300-XP32-SP09-02	▲	30.0	32	37	63	83	60	143	SPMX090408- XM/LM/EM/XR	I60M3.5×8	WT15IP
ZSD02-305-XP32-SP09-02	▲	30.5	32	37	64	84	60	144	SPMX090408- XM/LM/EM/XR	I60M3.5×8	WT15IP
ZSD02-310-XP32-SP09-02	▲	31.0	32	37	65	85	60	145	SPMX090408- XM/LM/EM/XR	I60M3.5×8	WT15IP
ZSD02-315-XP32-SP09-02	▲	31.5	32	37	66	86	60	146	SPMX090408- XM/LM/EM/XR	I60M3.5×8	WT15IP
ZSD02-320-XP32-SP09-02	▲	32.0	32	37	67	87	60	147	SPMX090408- XM/LM/EM/XR	I60M3.5×8	WT15IP
ZSD02-325-XP32-SP09-02	▲	32.5	32	37	68	88	60	148	SPMX090408- XM/LM/EM/XR	I60M3.5×8	WT15IP
ZSD02-330-XP32-SP09-02	▲	33.0	32	37	69	89	60	149	SPMX090408- XM/LM/EM/XR	I60M3.5×8	WT15IP
ZSD02-335-XP32-SP09-02	▲	33.5	32	37	70	90	60	150	SPMX090408- XM/LM/EM/XR	I60M3.5×8	WT15IP
ZSD02-340-XP40-SP11-02	▲	34.0	40	47	71	96	70	166	SPMX110408- XM/LM/EM/XR	I60M4×10	WT15IP
ZSD02-345-XP40-SP11-02	△	34.5	40	47	72	97	70	167	SPMX110408- XM/LM/EM/XR	I60M4×10	WT15IP
ZSD02-350-XP40-SP11-02	▲	35.0	40	47	73	98	70	168	SPMX110408- XM/LM/EM/XR	I60M4×10	WT15IP
ZSD02-355-XP40-SP11-02	△	35.5	40	47	74	99	70	169	SPMX110408- XM/LM/EM/XR	I60M4×10	WT15IP
ZSD02-360-XP40-SP11-02	▲	36.0	40	47	75	100	70	170	SPMX110408- XM/LM/EM/XR	I60M4×10	WT15IP
ZSD02-365-XP40-SP11-02	△	36.5	40	47	76	101	70	171	SPMX110408- XM/LM/EM/XR	I60M4×10	WT15IP
ZSD02-370-XP40-SP11-02	▲	37.0	40	47	77	102	70	172	SPMX110408- XM/LM/EM/XR	I60M4×10	WT15IP
ZSD02-375-XP40-SP11-02	△	37.5	40	47	78	103	70	173	SPMX110408- XM/LM/EM/XR	I60M4×10	WT15IP
ZSD02-380-XP40-SP11-02	▲	38.0	40	47	79	104	70	174	SPMX110408- XM/LM/EM/XR	I60M4×10	WT15IP
ZSD02-385-XP40-SP11-02	△	38.5	40	47	80	105	70	175	SPMX110408- XM/LM/EM/XR	I60M4×10	WT15IP
ZSD02-390-XP40-SP11-02	▲	39.0	40	47	81	106	70	176	SPMX110408- XM/LM/EM/XR	I60M4×10	WT15IP
ZSD02-395-XP40-SP11-02	△	39.5	40	47	82	107	70	177	SPMX110408- XM/LM/EM/XR	I60M4×10	WT15IP
ZSD02-400-XP40-SP11-02	▲	40.0	40	47	83	108	70	178	SPMX110408- XM/LM/EM/XR	I60M4×10	WT15IP
ZSD02-405-XP40-SP11-02	△	40.5	40	47	84	109	70	179	SPMX110408- XM/LM/EM/XR	I60M4×10	WT15IP
ZSD02-410-XP40-SP11-02	▲	41.0	40	47	85	110	70	180	SPMX110408- XM/LM/EM/XR	I60M4×10	WT15IP
ZSD02-415-XP40-SP11-02	△	41.5	40	47	86	111	70	181	SPMX110408- XM/LM/EM/XR	I60M4×10	WT15IP
ZSD02-420-XP40-SP11-02	▲	42.0	40	52	87	119	70	189	SPMX110408- XM/LM/EM/XR	I60M4×10	WT15IP
ZSD02-425-XP40-SP14-02	△	42.5	40	52	88	120	70	190	SPMX140512- XM/LM/EM/XR	I60M5×13	WT20IP

▲Stock available △Make-to-order

Drilling tools

U drills



Type	Stock	Basic dimension(mm)							Applicable inserts	Insert screw 	Wrench 
		ØD	ØD ₁	ØD ₂	L ₁	L ₂	L _s	L			
ZSD02-430-XP40-SP14-02	▲	43.0	40	52	89	121	70	191	SPMX140512- XM/LM/EM/XR	I60M5×13	WT20IP
ZSD02-435-XP40-SP14-02	△	43.5	40	52	90	122	70	192	SPMX140512- XM/LM/EM/XR	I60M5×13	WT20IP
ZSD02-440-XP40-SP14-02	▲	44.0	40	52	91	123	70	193	SPMX140512- XM/LM/EM/XR	I60M5×13	WT20IP
ZSD02-445-XP40-SP14-02	△	44.5	40	52	92	124	70	194	SPMX140512- XM/LM/EM/XR	I60M5×13	WT20IP
ZSD02-450-XP40-SP14-02	▲	45.0	40	52	93	125	70	195	SPMX140512- XM/LM/EM/XR	I60M5×13	WT20IP
ZSD02-455-XP40-SP14-02	△	45.5	40	52	94	126	70	196	SPMX140512- XM/LM/EM/XR	I60M5×13	WT20IP
ZSD02-460-XP40-SP14-02	▲	46.0	40	52	95	127	70	197	SPMX140512- XM/LM/EM/XR	I60M5×13	WT20IP
ZSD02-465-XP40-SP14-02	△	46.5	40	52	96	128	70	198	SPMX140512- XM/LM/EM/XR	I60M5×13	WT20IP
ZSD02-470-XP40-SP14-02	▲	47.0	40	52	97	129	70	199	SPMX140512- XM/LM/EM/XR	I60M5×13	WT20IP
ZSD02-475-XP40-SP14-02	△	47.5	40	52	98	130	70	200	SPMX140512- XM/LM/EM/XR	I60M5×13	WT20IP
ZSD02-480-XP40-SP14-02	▲	48.0	40	52	99	131	70	201	SPMX140512- XM/LM/EM/XR	I60M5×13	WT20IP
ZSD02-485-XP40-SP14-02	△	48.5	40	52	100	132	70	202	SPMX140512- XM/LM/EM/XR	I60M5×13	WT20IP
ZSD02-490-XP40-SP14-02	▲	49.0	40	52	101	133	70	203	SPMX140512- XM/LM/EM/XR	I60M5×13	WT20IP
ZSD02-495-XP40-SP14-02	△	49.5	40	52	102	134	70	204	SPMX140512- XM/LM/EM/XR	I60M5×13	WT20IP
ZSD02-500-XP40-SP14-02	▲	50.0	40	52	103	135	70	205	SPMX140512- XM/LM/EM/XR	I60M5×13	WT20IP

▲Stock available △Make-to-order



U drills

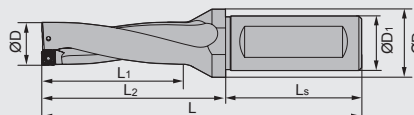

ZSD03 3D



Type	Stock	Basic dimension(mm)							Applicable inserts	Insert screw	Wrench
		ØD	ØD ₁	ØD ₂	L ₁	L ₂	L _s	L			
ZSD03-120-XP20-SP04-02	▲	12.0	20	25	39	55	50	105	SPMX040203-XM/LM/EM/XR	I60M1.8×4.5	WT05IP
ZSD03-125-XP20-SP04-02	▲	12.5	20	25	41	57	50	107	SPMX040203-XM/LM/EM/XR	I60M1.8×4.5	WT05IP
ZSD03-130-XP20-SP04-02	▲	13.0	20	25	42	58	50	108	SPMX040203-XM/LM/EM/XR	I60M1.8×4.5	WT05IP
ZSD03-135-XP20-SP04-02	▲	13.5	20	25	44	60	50	110	SPMX040203-XM/LM/EM/XR	I60M1.8×4.5	WT05IP
ZSD03-140-XP20-SP04-02	▲	14.0	20	25	45	61	50	111	SPMX040203-XM/LM/EM/XR	I60M1.8×4.5	WT05IP
ZSD03-145-XP20-SP04-02	▲	14.5	20	25	47	63	50	113	SPMX040203-XM/LM/EM/XR	I60M1.8×4.5	WT05IP
ZSD03-150-XP20-SP05-02	▲	15.0	20	25	48	64	50	114	SPMX050204-XM/LM/EM/XR	I60M2×4.3	WT06P
ZSD03-155-XP20-SP05-02	▲	15.5	20	25	50	66	50	116	SPMX050204-XM/LM/EM/XR	I60M2×4.3	WT06P
ZSD03-160-XP20-SP05-02	▲	16.0	20	25	51	67	50	117	SPMX050204-XM/LM/EM/XR	I60M2×4.3	WT06P
ZSD03-165-XP20-SP05-02	▲	16.5	20	25	53	69	50	119	SPMX050204-XM/LM/EM/XR	I60M2×4.3	WT06P
ZSD03-170-XP20-SP05-02	▲	17.0	20	25	54	70	50	120	SPMX050204-XM/LM/EM/XR	I60M2×4.3	WT06P
ZSD03-175-XP20-SP05-02	▲	17.5	20	25	56	72	50	122	SPMX050204-XM/LM/EM/XR	I60M2×4.3	WT06P
ZSD03-180-XP25-SP06-02	▲	18.0	25	32	57	75	56	131	SPMX060204-XM/LM/EM/XR	I60M2.2×5.5	WT07IP
ZSD03-185-XP25-SP06-02	▲	18.5	25	32	59	77	56	133	SPMX060204-XM/LM/EM/XR	I60M2.2×5.5	WT07IP
ZSD03-190-XP25-SP06-02	▲	19.0	25	32	60	78	56	134	SPMX060204-XM/LM/EM/XR	I60M2.2×5.5	WT07IP
ZSD03-195-XP25-SP06-02	▲	19.5	25	32	62	80	56	136	SPMX060204-XM/LM/EM/XR	I60M2.2×5.5	WT07IP
ZSD03-200-XP25-SP06-02	▲	20.0	25	32	63	81	56	137	SPMX060204-XM/LM/EM/XR	I60M2.2×5.5	WT07IP
ZSD03-205-XP25-SP06-02	▲	20.5	25	32	65	83	56	139	SPMX060204-XM/LM/EM/XR	I60M2.2×5.5	WT07IP
ZSD03-210-XP25-SP06-02	▲	21.0	25	32	66	84	56	140	SPMX060204-XM/LM/EM/XR	I60M2.2×5.5	WT07IP
ZSD03-215-XP25-SP06-02	▲	21.5	25	32	68	86	56	142	SPMX060204-XM/LM/EM/XR	I60M2.2×5.5	WT07IP
ZSD03-220-XP25-SP06-02	▲	22.0	25	32	69	87	56	143	SPMX060204-XM/LM/EM/XR	I60M2.2×5.5	WT07IP
ZSD03-225-XP25-SP07-02	▲	22.5	25	32	71	89	56	145	SPMX07T308-XM/LM/EM/XR	I60M2.5×6.5	WT07IP
ZSD03-230-XP25-SP07-02	▲	23.0	25	32	72	91	56	147	SPMX07T308-XM/LM/EM/XR	I60M2.5×6.5	WT07IP
ZSD03-235-XP25-SP07-02	▲	23.5	25	32	74	93	56	149	SPMX07T308-XM/LM/EM/XR	I60M2.5×6.5	WT07IP
ZSD03-240-XP25-SP07-02	▲	24.0	25	32	75	94	56	150	SPMX07T308-XM/LM/EM/XR	I60M2.5×6.5	WT07IP
ZSD03-245-XP25-SP07-02	▲	24.5	25	32	77	96	56	152	SPMX07T308-XM/LM/EM/XR	I60M2.5×6.5	WT07IP

▲Stock available △Make-to-order



Type	Stock	Basic dimension(mm)							Applicable inserts	Insert screw 	Wrench 
		ØD	ØD ₁	ØD ₂	L ₁	L ₂	L _s	L			
ZSD03-250-XP25-SP07-02	▲	25.0	25	32	78	97	56	153	SPMX07T308- XM/LM/EM/XR	I60M2.5×6.5	WT071P
ZSD03-255-XP25-SP07-02	▲	25.5	25	32	80	99	56	155	SPMX07T308- XM/LM/EM/XR	I60M2.5×6.5	WT071P
ZSD03-260-XP25-SP07-02	▲	26.0	25	32	81	100	56	156	SPMX07T308- XM/LM/EM/XR	I60M2.5×6.5	WT071P
ZSD03-265-XP25-SP07-02	▲	26.5	25	32	83	102	56	158	SPMX07T308- XM/LM/EM/XR	I60M2.5×6.5	WT071P
ZSD03-270-XP25-SP07-02	▲	27.0	25	32	84	104	56	160	SPMX07T308- XM/LM/EM/XR	I60M2.5×6.5	WT071P
ZSD03-275-XP25-SP07-02	▲	27.5	25	32	86	106	56	162	SPMX07T308- XM/LM/EM/XR	I60M2.5×6.5	WT071P
ZSD03-280-XP32-SP09-02	▲	28.0	32	37	87	109	60	169	SPMX090408- XM/LM/EM/XR	I60M3.5×8	WT151P
ZSD03-285-XP32-SP09-02	▲	28.5	32	37	89	111	60	171	SPMX090408- XM/LM/EM/XR	I60M3.5×8	WT151P
ZSD03-290-XP32-SP09-02	▲	29.0	32	37	90	112	60	172	SPMX090408- XM/LM/EM/XR	I60M3.5×8	WT151P
ZSD03-295-XP32-SP09-02	▲	29.5	32	37	92	114	60	174	SPMX090408- XM/LM/EM/XR	I60M3.5×8	WT151P
ZSD03-300-XP32-SP09-02	▲	30.0	32	37	93	115	60	175	SPMX090408- XM/LM/EM/XR	I60M3.5×8	WT151P
ZSD03-305-XP32-SP09-02	▲	30.5	32	37	95	117	60	177	SPMX090408- XM/LM/EM/XR	I60M3.5×8	WT151P
ZSD03-310-XP32-SP09-02	▲	31.0	32	37	96	118	60	178	SPMX090408- XM/LM/EM/XR	I60M3.5×8	WT151P
ZSD03-315-XP32-SP09-02	▲	31.5	32	37	98	120	60	180	SPMX090408- XM/LM/EM/XR	I60M3.5×8	WT151P
ZSD03-320-XP32-SP09-02	▲	32.0	32	37	99	121	60	181	SPMX090408- XM/LM/EM/XR	I60M3.5×8	WT151P
ZSD03-325-XP32-SP09-02	▲	32.5	32	37	101	123	60	183	SPMX090408- XM/LM/EM/XR	I60M3.5×8	WT151P
ZSD03-330-XP32-SP09-02	▲	33.0	32	37	102	124	60	184	SPMX090408- XM/LM/EM/XR	I60M3.5×8	WT151P
ZSD03-335-XP32-SP09-02	▲	33.5	32	37	104	126	60	186	SPMX090408- XM/LM/EM/XR	I60M3.5×8	WT151P
ZSD03-340-XP40-SP11-02	▲	34.0	40	47	105	130	70	200	SPMX110408- XM/LM/EM/XR	I60M4×10	WT151P
ZSD03-345-XP40-SP11-02	△	34.5	40	47	107	132	70	202	SPMX110408- XM/LM/EM/XR	I60M4×10	WT151P
ZSD03-350-XP40-SP11-02	▲	35.0	40	47	108	133	70	203	SPMX110408- XM/LM/EM/XR	I60M4×10	WT151P
ZSD03-355-XP40-SP11-02	△	35.5	40	47	100	135	70	205	SPMX110408- XM/LM/EM/XR	I60M4×10	WT151P
ZSD03-360-XP40-SP11-02	▲	36.0	40	47	111	136	70	206	SPMX110408- XM/LM/EM/XR	I60M4×10	WT151P
ZSD03-365-XP40-SP11-02	△	36.5	40	47	113	138	70	208	SPMX110408- XM/LM/EM/XR	I60M4×10	WT151P
ZSD03-370-XP40-SP11-02	▲	37.0	40	47	114	139	70	209	SPMX110408- XM/LM/EM/XR	I60M4×10	WT151P
ZSD03-375-XP40-SP11-02	△	37.5	40	47	116	141	70	211	SPMX110408- XM/LM/EM/XR	I60M4×10	WT151P
ZSD03-380-XP40-SP11-02	▲	38.0	40	47	117	142	70	212	SPMX110408- XM/LM/EM/XR	I60M4×10	WT151P
ZSD03-385-XP40-SP11-02	△	38.5	40	47	119	144	70	214	SPMX110408- XM/LM/EM/XR	I60M4×10	WT151P
ZSD03-390-XP40-SP11-02	▲	39.0	40	47	120	145	70	215	SPMX110408- XM/LM/EM/XR	I60M4×10	WT151P
ZSD03-395-XP40-SP11-02	△	39.5	40	47	122	147	70	217	SPMX110408- XM/LM/EM/XR	I60M4×10	WT151P
ZSD03-400-XP40-SP11-02	▲	40.0	40	47	123	148	70	218	SPMX110408- XM/LM/EM/XR	I60M4×10	WT151P
ZSD03-405-XP40-SP11-02	△	40.5	40	47	125	150	70	220	SPMX110408- XM/LM/EM/XR	I60M4×10	WT151P
ZSD03-410-XP40-SP11-02	▲	41.0	40	47	126	151	70	221	SPMX110408- XM/LM/EM/XR	I60M4×10	WT151P
ZSD03-415-XP40-SP11-02	△	41.5	40	47	128	153	70	223	SPMX110408- XM/LM/EM/XR	I60M4×10	WT151P
ZSD03-420-XP40-SP11-02	▲	42.0	40	52	129	161	70	231	SPMX110408- XM/LM/EM/XR	I60M4×10	WT151P

▲Stock available △Make-to-order

Drilling tools



U drills

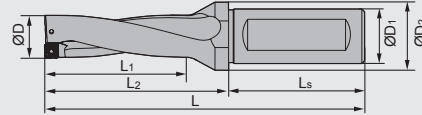

U drills

ZSD03 3D



Type	Stock	Basic dimension(mm)							Applicable inserts	Insert screw 	Wrench 
		ØD	ØD ₁	ØD ₂	L ₁	L ₂	L _s	L			
ZSD03-425-XP40-SP14-02	△	42.5	40	52	131	163	70	233	SPMX140512- XM/LM/EM/XR	I60M5×13	WT20IP
ZSD03-430-XP40-SP14-02	▲	43.0	40	52	132	164	70	234	SPMX140512- XM/LM/EM/XR	I60M5×13	WT20IP
ZSD03-435-XP40-SP14-02	△	43.5	40	52	134	166	70	236	SPMX140512- XM/LM/EM/XR	I60M5×13	WT20IP
ZSD03-440-XP40-SP14-02	▲	44.0	40	52	135	167	70	237	SPMX140512- XM/LM/EM/XR	I60M5×13	WT20IP
ZSD03-445-XP40-SP14-02	△	44.5	40	52	137	169	70	239	SPMX140512- XM/LM/EM/XR	I60M5×13	WT20IP
ZSD03-450-XP40-SP14-02	▲	45.0	40	52	138	170	70	240	SPMX140512- XM/LM/EM/XR	I60M5×13	WT20IP
ZSD03-455-XP40-SP14-02	△	45.5	40	52	140	172	70	242	SPMX140512- XM/LM/EM/XR	I60M5×13	WT20IP
ZSD03-460-XP40-SP14-02	▲	46.0	40	52	141	173	70	243	SPMX140512- XM/LM/EM/XR	I60M5×13	WT20IP
ZSD03-465-XP40-SP14-02	△	46.5	40	52	142	175	70	245	SPMX140512- XM/LM/EM/XR	I60M5×13	WT20IP
ZSD03-470-XP40-SP14-02	▲	47.0	40	52	144	176	70	246	SPMX140512- XM/LM/EM/XR	I60M5×13	WT20IP
ZSD03-475-XP40-SP14-02	△	47.5	40	52	146	178	70	248	SPMX140512- XM/LM/EM/XR	I60M5×13	WT20IP
ZSD03-480-XP40-SP14-02	▲	48.0	40	52	147	179	70	249	SPMX140512- XM/LM/EM/XR	I60M5×13	WT20IP
ZSD03-485-XP40-SP14-02	△	48.5	40	52	149	181	70	251	SPMX140512- XM/LM/EM/XR	I60M5×13	WT20IP
ZSD03-490-XP40-SP14-02	▲	49.0	40	52	150	182	70	252	SPMX140512- XM/LM/EM/XR	I60M5×13	WT20IP
ZSD03-495-XP40-SP14-02	△	49.5	40	52	152	184	70	254	SPMX140512- XM/LM/EM/XR	I60M5×13	WT20IP
ZSD03-500-XP40-SP14-02	▲	50.0	40	52	153	185	70	255	SPMX140512- XM/LM/EM/XR	I60M5×13	WT20IP



▲Stock available △Make-to-order

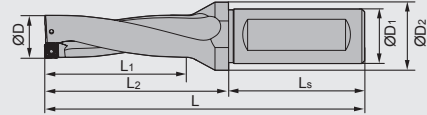

U drills

ZSD04 4D



Type	Stock	Basic dimension(mm)							Applicable inserts	Insert screw 	Wrench 
		ØD	ØD ₁	ØD ₂	L ₁	L ₂	L _s	L			
ZSD04-120-XP20-SP04-02	▲	12.0	20	25	51	67	50	117	SPMX040203-XM/LM/EM/XR	I60M1.8×4.5	WT05IP
ZSD04-125-XP20-SP04-02	▲	12.5	20	25	53	69	50	119	SPMX040203-XM/LM/EM/XR	I60M1.8×4.5	WT05IP
ZSD04-130-XP20-SP04-02	▲	13.0	20	25	55	71	50	121	SPMX040203-XM/LM/EM/XR	I60M1.8×4.5	WT05IP
ZSD04-135-XP20-SP04-02	▲	13.5	20	25	57	73	50	123	SPMX040203-XM/LM/EM/XR	I60M1.8×4.5	WT05IP
ZSD04-140-XP20-SP04-02	▲	14.0	20	25	59	75	50	125	SPMX040203-XM/LM/EM/XR	I60M1.8×4.5	WT05IP
ZSD04-145-XP20-SP04-02	▲	14.5	20	25	61	77	50	127	SPMX040203-XM/LM/EM/XR	I60M1.8×4.5	WT05IP
ZSD04-150-XP20-SP05-02	▲	15.0	20	25	63	79	50	129	SPMX050204-XM/LM/EM/XR	I60M2×4.3	WT06P
ZSD04-155-XP20-SP05-02	▲	15.5	20	25	65	81	50	131	SPMX050204-XM/LM/EM/XR	I60M2×4.3	WT06P
ZSD04-160-XP20-SP05-02	▲	16.0	20	25	67	83	50	133	SPMX050204-XM/LM/EM/XR	I60M2×4.3	WT06P
ZSD04-165-XP20-SP05-02	▲	16.5	20	25	69	85	50	135	SPMX050204-XM/LM/EM/XR	I60M2×4.3	WT06P
ZSD04-170-XP20-SP05-02	▲	17.0	20	25	71	87	50	137	SPMX050204-XM/LM/EM/XR	I60M2×4.3	WT06P
ZSD04-175-XP20-SP05-02	▲	17.5	20	25	73	89	50	139	SPMX050204-XM/LM/EM/XR	I60M2×4.3	WT06P
ZSD04-180-XP25-SP06-02	▲	18.0	25	32	75	93	56	149	SPMX060204- XM/LM/EM/XR	I60M2.2×5.5	WT07IP
ZSD04-185-XP25-SP06-02	▲	18.5	25	32	77	95	56	151	SPMX060204- XM/LM/EM/XR	I60M2.2×5.5	WT07IP
ZSD04-190-XP25-SP06-02	▲	19.0	25	32	79	97	56	153	SPMX060204- XM/LM/EM/XR	I60M2.2×5.5	WT07IP
ZSD04-195-XP25-SP06-02	▲	19.5	25	32	81	99	56	155	SPMX060204- XM/LM/EM/XR	I60M2.2×5.5	WT07IP
ZSD04-200-XP25-SP06-02	▲	20.0	25	32	83	101	56	157	SPMX060204- XM/LM/EM/XR	I60M2.2×5.5	WT07IP
ZSD04-205-XP25-SP06-02	▲	20.5	25	32	85	103	56	159	SPMX060204- XM/LM/EM/XR	I60M2.2×5.5	WT07IP
ZSD04-210-XP25-SP06-02	▲	21.0	25	32	87	105	56	161	SPMX060204- XM/LM/EM/XR	I60M2.2×5.5	WT07IP
ZSD04-215-XP25-SP06-02	▲	21.5	25	32	89	107	56	163	SPMX060204- XM/LM/EM/XR	I60M2.2×5.5	WT07IP
ZSD04-220-XP25-SP06-02	▲	22.0	25	32	91	109	56	165	SPMX060204- XM/LM/EM/XR	I60M2.2×5.5	WT07IP
ZSD04-225-XP25-SP07-02	▲	22.5	25	32	93	111	56	167	SPMX07T308- XM/LM/EM/XR	I60M2.5×6.5	WT07IP
ZSD04-230-XP25-SP07-02	▲	23.0	25	32	95	114	56	170	SPMX07T308- XM/LM/EM/XR	I60M2.5×6.5	WT07IP
ZSD04-235-XP25-SP07-02	▲	23.5	25	32	97	116	56	172	SPMX07T308- XM/LM/EM/XR	I60M2.5×6.5	WT07IP
ZSD04-240-XP25-SP07-02	▲	24.0	25	32	99	118	56	174	SPMX07T308- XM/LM/EM/XR	I60M2.5×6.5	WT07IP
ZSD04-245-XP25-SP07-02	▲	24.5	25	32	101	120	56	176	SPMX07T308- XM/LM/EM/XR	I60M2.5×6.5	WT07IP
ZSD04-250-XP25-SP07-02	▲	25.0	25	32	103	122	56	178	SPMX07T308- XM/LM/EM/XR	I60M2.5×6.5	WT07IP
ZSD04-250-XP32-SP07-02	▲	25.0	32	37	103	122	60	182	SPMX07T308- XM/LM/EM/XR	I60M2.5×6.5	WT07IP
ZSD04-255-XP25-SP07-02	▲	25.5	25	32	105	125	56	181	SPMX07T308- XM/LM/EM/XR	I60M2.5×6.5	WT07IP
ZSD04-255-XP32-SP07-02	▲	25.5	32	37	105	125	60	185	SPMX07T308- XM/LM/EM/XR	I60M2.5×6.5	WT07IP
ZSD04-260-XP25-SP07-02	▲	26.0	25	32	107	126	56	182	SPMX07T308- XM/LM/EM/XR	I60M2.5×6.5	WT07IP

▲ Stock available △ Make-to-order



U drills

ZSD04 4D

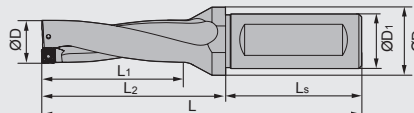



Type	Stock	Basic dimension(mm)							Applicable inserts	Insert screw	Wrench
		ØD	ØD ₁	ØD ₂	L ₁	L ₂	L _s	L			
ZSD04-260-XP32-SP07-02	▲	26.0	32	37	107	126	60	186	SPMX07T308- XM/LM/EM/XR	I60M2.5×6.5	WT07IP
ZSD04-265-XP25-SP07-02	▲	26.5	25	32	109	128	56	184	SPMX07T308- XM/LM/EM/XR	I60M2.5×6.5	WT07IP
ZSD04-265-XP32-SP07-02	▲	26.5	32	37	109	128	60	188	SPMX07T308- XM/LM/EM/XR	I60M2.5×6.5	WT07IP
ZSD04-270-XP25-SP07-02	▲	27.0	25	32	111	131	56	187	SPMX07T308- XM/LM/EM/XR	I60M2.5×6.5	WT07IP
ZSD04-270-XP32-SP07-02	▲	27.0	32	37	111	131	60	191	SPMX07T308- XM/LM/EM/XR	I60M2.5×6.5	WT07IP
ZSD04-275-XP25-SP07-02	▲	27.5	25	32	113	134	56	190	SPMX07T308- XM/LM/EM/XR	I60M2.5×6.5	WT07IP
ZSD04-275-XP32-SP07-02	▲	27.5	32	37	113	134	60	194	SPMX07T308- XM/LM/EM/XR	I60M2.5×6.5	WT07IP
ZSD04-280-XP32-SP09-02	▲	28.0	32	37	115	139	60	199	SPMX090408- XM/LM/EM/XR	I60M3.5×8	WT15IP
ZSD04-285-XP32-SP09-02	▲	28.5	32	37	117	141	60	201	SPMX090408- XM/LM/EM/XR	I60M3.5×8	WT15IP
ZSD04-290-XP32-SP09-02	▲	29.0	32	37	119	143	60	203	SPMX090408- XM/LM/EM/XR	I60M3.5×8	WT15IP
ZSD04-295-XP32-SP09-02	▲	29.5	32	37	121	145	60	205	SPMX090408- XM/LM/EM/XR	I60M3.5×8	WT15IP
ZSD04-300-XP32-SP09-02	▲	30.0	32	37	123	147	60	207	SPMX090408- XM/LM/EM/XR	I60M3.5×8	WT15IP
ZSD04-305-XP32-SP09-02	▲	30.5	32	37	125	149	60	209	SPMX090408- XM/LM/EM/XR	I60M3.5×8	WT15IP
ZSD04-310-XP32-SP09-02	▲	31.0	32	37	127	151	60	211	SPMX090408- XM/LM/EM/XR	I60M3.5×8	WT15IP
ZSD04-315-XP32-SP09-02	▲	31.5	32	37	129	153	60	213	SPMX090408- XM/LM/EM/XR	I60M3.5×8	WT15IP
ZSD04-320-XP32-SP09-02	▲	32.0	32	37	131	155	60	215	SPMX090408- XM/LM/EM/XR	I60M3.5×8	WT15IP
ZSD04-320-XP40-SP09-02	▲	32.0	40	47	131	155	70	225	SPMX090408- XM/LM/EM/XR	I60M3.5×8	WT15IP
ZSD04-325-XP32-SP09-02	▲	32.5	32	37	133	157	60	217	SPMX090408- XM/LM/EM/XR	I60M3.5×8	WT15IP
ZSD04-325-XP40-SP09-02	▲	32.5	40	47	133	157	70	227	SPMX090408- XM/LM/EM/XR	I60M3.5×8	WT15IP
ZSD04-330-XP32-SP09-02	▲	33.0	32	37	135	159	60	219	SPMX090408- XM/LM/EM/XR	I60M3.5×8	WT15IP
ZSD04-330-XP40-SP09-02	▲	33.0	40	47	135	159	70	229	SPMX090408- XM/LM/EM/XR	I60M3.5×8	WT15IP
ZSD04-335-XP32-SP09-02	▲	33.5	32	37	137	161	60	221	SPMX090408- XM/LM/EM/XR	I60M3.5×8	WT15IP
ZSD04-335-XP40-SP09-02	▲	33.5	40	47	137	161	70	231	SPMX090408- XM/LM/EM/XR	I60M3.5×8	WT15IP
ZSD04-340-XP40-SP11-02	▲	34.0	40	47	139	164	70	234	SPMX110408- XM/LM/EM/XR	I60M4×10	WT15IP
ZSD04-345-XP40-SP11-02	△	34.5	40	47	141	166	70	236	SPMX110408- XM/LM/EM/XR	I60M4×10	WT15IP
ZSD04-350-XP40-SP11-02	▲	35.0	40	47	143	168	70	238	SPMX110408- XM/LM/EM/XR	I60M4×10	WT15IP
ZSD04-355-XP40-SP11-02	△	35.5	40	47	145	170	70	240	SPMX110408- XM/LM/EM/XR	I60M4×10	WT15IP
ZSD04-360-XP40-SP11-02	▲	36.0	40	47	147	172	70	242	SPMX110408- XM/LM/EM/XR	I60M4×10	WT15IP
ZSD04-365-XP40-SP11-02	△	36.5	40	47	149	174	70	244	SPMX110408- XM/LM/EM/XR	I60M4×10	WT15IP
ZSD04-370-XP40-SP11-02	▲	37.0	40	47	151	176	70	246	SPMX110408- XM/LM/EM/XR	I60M4×10	WT15IP
ZSD04-375-XP40-SP11-02	△	37.5	40	47	153	178	70	248	SPMX110408- XM/LM/EM/XR	I60M4×10	WT15IP

▲Stock available △Make-to-order

Drilling tools

U drills



Type	Stock	Basic dimension(mm)							Applicable inserts	Insert screw 	Wrench 
		ØD	ØD ₁	ØD ₂	L ₁	L ₂	L _s	L			
ZSD04-380-XP40-SP11-02	▲	38.0	40	47	155	180	70	250	SPMX110408-XM/LM/EM/XR	I60M4×10	WT15IP
ZSD04-385-XP40-SP11-02	△	38.5	40	47	157	182	70	252	SPMX110408-XM/LM/EM/XR	I60M4×10	WT15IP
ZSD04-390-XP40-SP11-02	▲	39.0	40	47	159	184	70	254	SPMX110408-XM/LM/EM/XR	I60M4×10	WT15IP
ZSD04-395-XP40-SP11-02	△	39.5	40	47	161	186	70	256	SPMX110408-XM/LM/EM/XR	I60M4×10	WT15IP
ZSD04-400-XP40-SP11-02	▲	40.0	40	47	163	188	70	258	SPMX110408-XM/LM/EM/XR	I60M4×10	WT15IP
ZSD04-405-XP40-SP11-02	△	40.5	40	47	165	190	70	260	SPMX110408-XM/LM/EM/XR	I60M4×10	WT15IP
ZSD04-410-XP40-SP11-02	▲	41.0	40	47	167	192	70	262	SPMX110408-XM/LM/EM/XR	I60M4×10	WT15IP
ZSD04-415-XP40-SP11-02	△	41.5	40	47	169	194	70	264	SPMX110408-XM/LM/EM/XR	I60M4×10	WT15IP
ZSD04-420-XP40-SP11-02	▲	42.0	40	52	171	203	70	273	SPMX110408-XM/LM/EM/XR	I60M4×10	WT15IP
ZSD04-420-XP50-SP11-02	△	42.0	50	57	171	203	80	283	SPMX110408-XM/LM/EM/XR	I60M4×10	WT15IP
ZSD04-425-XP40-SP14-02	△	42.5	40	52	173	205	70	275	SPMX140512-XM/LM/EM/XR	I60M5×13	WT20IP
ZSD04-425-XP50-SP14-02	△	42.5	50	57	173	205	80	285	SPMX140512-XM/LM/EM/XR	I60M5×13	WT20IP
ZSD04-430-XP40-SP14-02	▲	43.0	40	52	175	207	70	277	SPMX140512-XM/LM/EM/XR	I60M5×13	WT20IP
ZSD04-430-XP50-SP14-02	△	43.0	50	57	175	207	80	287	SPMX140512-XM/LM/EM/XR	I60M5×13	WT20IP
ZSD04-435-XP40-SP14-02	△	43.5	40	52	177	209	70	279	SPMX140512-XM/LM/EM/XR	I60M5×13	WT20IP
ZSD04-435-XP50-SP14-02	△	43.5	50	57	177	209	80	289	SPMX140512-XM/LM/EM/XR	I60M5×13	WT20IP
ZSD04-440-XP40-SP14-02	▲	44.0	40	52	179	211	70	281	SPMX140512-XM/LM/EM/XR	I60M5×13	WT20IP
ZSD04-440-XP50-SP14-02	△	44.0	50	57	179	211	80	291	SPMX140512-XM/LM/EM/XR	I60M5×13	WT20IP
ZSD04-445-XP40-SP14-02	△	44.5	40	52	181	213	70	283	SPMX140512-XM/LM/EM/XR	I60M5×13	WT20IP
ZSD04-445-XP50-SP14-02	△	44.5	50	57	181	213	80	293	SPMX140512-XM/LM/EM/XR	I60M5×13	WT20IP
ZSD04-450-XP40-SP14-02	▲	45.0	40	52	183	215	70	285	SPMX140512-XM/LM/EM/XR	I60M5×13	WT20IP
ZSD04-450-XP50-SP14-02	△	45.0	50	57	183	225	80	295	SPMX140512-XM/LM/EM/XR	I60M5×13	WT20IP
ZSD04-455-XP40-SP14-02	△	45.5	40	52	185	217	70	287	SPMX140512-XM/LM/EM/XR	I60M5×13	WT20IP
ZSD04-455-XP50-SP14-02	△	45.5	50	57	185	217	80	297	SPMX140512-XM/LM/EM/XR	I60M5×13	WT20IP
ZSD04-460-XP40-SP14-02	▲	46.0	40	52	187	219	70	289	SPMX140512-XM/LM/EM/XR	I60M5×13	WT20IP
ZSD04-460-XP50-SP14-02	△	46.0	50	57	187	219	80	299	SPMX140512-XM/LM/EM/XR	I60M5×13	WT20IP
ZSD04-465-XP40-SP14-02	△	46.5	40	52	189	221	70	291	SPMX140512-XM/LM/EM/XR	I60M5×13	WT20IP
ZSD04-465-XP50-SP14-02	△	46.5	50	57	189	221	80	301	SPMX140512-XM/LM/EM/XR	I60M5×13	WT20IP
ZSD04-470-XP40-SP14-02	▲	47.0	40	52	191	223	70	293	SPMX140512-XM/LM/EM/XR	I60M5×13	WT20IP
ZSD04-470-XP50-SP14-02	△	47.0	50	57	191	223	80	303	SPMX140512-XM/LM/EM/XR	I60M5×13	WT20IP
ZSD04-475-XP40-SP14-02	△	47.5	40	52	193	225	70	295	SPMX140512-XM/LM/EM/XR	I60M5×13	WT20IP
ZSD04-475-XP50-SP14-02	△	47.5	50	57	193	225	80	305	SPMX140512-XM/LM/EM/XR	I60M5×13	WT20IP
ZSD04-480-XP40-SP14-02	▲	48.0	40	52	195	227	70	297	SPMX140512-XM/LM/EM/XR	I60M5×13	WT20IP
ZSD04-480-XP50-SP14-02	△	48.0	50	57	195	227	80	307	SPMX140512-XM/LM/EM/XR	I60M5×13	WT20IP
ZSD04-485-XP40-SP14-02	△	48.5	40	52	197	229	70	299	SPMX140512-XM/LM/EM/XR	I60M5×13	WT20IP
ZSD04-485-XP50-SP14-02	△	48.5	50	57	197	229	80	309	SPMX140512-XM/LM/EM/XR	I60M5×13	WT20IP
ZSD04-490-XP40-SP14-02	▲	49.0	40	52	199	231	70	301	SPMX140512-XM/LM/EM/XR	I60M5×13	WT20IP
ZSD04-490-XP50-SP14-02	△	49.0	50	57	199	231	80	311	SPMX140512-XM/LM/EM/XR	I60M5×13	WT20IP
ZSD04-495-XP40-SP14-02	△	49.5	40	52	201	233	70	303	SPMX140512-XM/LM/EM/XR	I60M5×13	WT20IP
ZSD04-495-XP50-SP14-02	△	49.5	50	57	201	233	80	313	SPMX140512-XM/LM/EM/XR	I60M5×13	WT20IP
ZSD04-500-XP40-SP14-02	▲	50.0	40	52	203	235	70	305	SPMX140512-XM/LM/EM/XR	I60M5×13	WT20IP
ZSD04-500-XP50-SP14-02	△	50.0	50	57	203	235	80	315	SPMX140512-XM/LM/EM/XR	I60M5×13	WT20IP

▲Stock available △Make-to-order

Drilling tools

U drills



U drills

U drills

ZSD05 5D

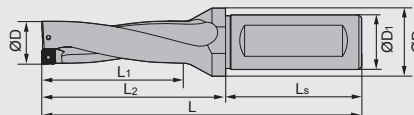



Type	Stock	Basic dimension(mm)							Applicable inserts	Insert screw	Wrench
		ØD	ØD1	ØD2	L1	L2	Ls	L			
ZSD05-120-XP20-SP04-02	▲	12.0	20	25	63	79	50	129	SPMX040203-XM/LM/EM/XR	I60M1.8×4.5	WT05IP
ZSD05-125-XP20-SP04-02	▲	12.5	20	25	66	82	50	132	SPMX040203-XM/LM/EM/XR	I60M1.8×4.5	WT05IP
ZSD05-130-XP20-SP04-02	▲	13.0	20	25	68	84	50	134	SPMX040203-XM/LM/EM/XR	I60M1.8×4.5	WT05IP
ZSD05-135-XP20-SP04-02	▲	13.5	20	25	71	87	50	137	SPMX040203-XM/LM/EM/XR	I60M1.8×4.5	WT05IP
ZSD05-140-XP20-SP04-02	▲	14.0	20	25	73	89	50	139	SPMX040203-XM/LM/EM/XR	I60M1.8×4.5	WT05IP
ZSD05-145-XP20-SP04-02	▲	14.5	20	25	76	91	50	141	SPMX040203-XM/LM/EM/XR	I60M1.8×4.5	WT05IP
ZSD05-150-XP20-SP05-02	▲	15.0	20	25	78	94	50	144	SPMX050204-XM/LM/EM/XR	I60M2×4.3	WT06P
ZSD05-155-XP20-SP05-02	▲	15.5	20	25	81	97	50	147	SPMX050204-XM/LM/EM/XR	I60M2×4.3	WT06P
ZSD05-160-XP20-SP05-02	▲	16.0	20	25	83	99	50	149	SPMX050204-XM/LM/EM/XR	I60M2×4.3	WT06P
ZSD05-165-XP20-SP05-02	▲	16.5	20	25	86	102	50	152	SPMX050204-XM/LM/EM/XR	I60M2×4.3	WT06P
ZSD05-170-XP20-SP05-02	▲	17.0	20	25	88	104	50	154	SPMX050204-XM/LM/EM/XR	I60M2×4.3	WT06P
ZSD05-175-XP20-SP05-02	▲	17.5	20	25	91	107	50	157	SPMX050204-XM/LM/EM/XR	I60M2×4.3	WT06P
ZSD05-180-XP25-SP06-02	▲	18.0	25	32	93	112	56	167	SPMX060204-XM/LM/EM/XR	I60M2.2×5.5	WT07IP
ZSD05-185-XP25-SP06-02	▲	18.5	25	32	96	114	56	170	SPMX060204-XM/LM/EM/XR	I60M2.2×5.5	WT07IP
ZSD05-190-XP25-SP06-02	▲	19.0	25	32	98	116	56	172	SPMX060204-XM/LM/EM/XR	I60M2.2×5.5	WT07IP
ZSD05-195-XP25-SP06-02	▲	19.5	25	32	101	119	56	175	SPMX060204-XM/LM/EM/XR	I60M2.2×5.5	WT07IP
ZSD05-200-XP25-SP06-02	▲	20.0	25	32	103	121	56	177	SPMX060204-XM/LM/EM/XR	I60M2.2×5.5	WT07IP
ZSD05-205-XP25-SP06-02	▲	20.5	25	32	106	124	56	180	SPMX060204-XM/LM/EM/XR	I60M2.2×5.5	WT07IP
ZSD05-210-XP25-SP06-02	▲	21.0	25	32	108	126	56	182	SPMX060204-XM/LM/EM/XR	I60M2.2×5.5	WT07IP
ZSD05-215-XP25-SP06-02	▲	21.5	25	32	111	129	56	185	SPMX060204-XM/LM/EM/XR	I60M2.2×5.5	WT07IP
ZSD05-220-XP25-SP06-02	▲	22.0	25	32	113	131	56	187	SPMX060204-XM/LM/EM/XR	I60M2.2×5.5	WT07IP
ZSD05-225-XP25-SP07-02	▲	22.5	25	32	116	134	56	190	SPMX07T308-XM/LM/EM/XR	I60M2.5×6.5	WT07IP
ZSD05-230-XP25-SP07-02	▲	23.0	25	32	118	138	56	194	SPMX07T308-XM/LM/EM/XR	I60M2.5×6.5	WT07IP
ZSD05-235-XP25-SP07-02	▲	23.5	25	32	121	141	56	197	SPMX07T308-XM/LM/EM/XR	I60M2.5×6.5	WT07IP
ZSD05-240-XP25-SP07-02	▲	24.0	25	32	123	143	56	199	SPMX07T308-XM/LM/EM/XR	I60M2.5×6.5	WT07IP
ZSD05-245-XP25-SP07-02	▲	24.5	25	32	126	146	56	202	SPMX07T308-XM/LM/EM/XR	I60M2.5×6.5	WT07IP
ZSD05-250-XP25-SP07-02	▲	25.0	25	32	128	148	56	204	SPMX07T308-XM/LM/EM/XR	I60M2.5×6.5	WT07IP
ZSD05-250-XP32-SP07-02	▲	25.0	32	37	128	148	60	208	SPMX07T308-XM/LM/EM/XR	I60M2.5×6.5	WT07IP
ZSD05-255-XP25-SP07-02	▲	25.5	25	32	131	151	56	207	SPMX07T308-XM/LM/EM/XR	I60M2.5×6.5	WT07IP
ZSD05-255-XP32-SP07-02	▲	25.5	32	37	131	151	60	211	SPMX07T308-XM/LM/EM/XR	I60M2.5×6.5	WT07IP
ZSD05-260-XP25-SP07-02	▲	26.0	25	32	133	153	56	209	SPMX07T308-XM/LM/EM/XR	I60M2.5×6.5	WT07IP
ZSD05-260-XP32-SP07-02	▲	26.0	32	37	133	153	60	213	SPMX07T308-XM/LM/EM/XR	I60M2.5×6.5	WT07IP

▲Stock available △Make-to-order

Drilling tools

U drills



Type	Stock	Basic dimension(mm)							Applicable inserts	Insert screw 	Wrench 
		ØD	ØD ₁	ØD ₂	L ₁	L ₂	L _s	L			
ZSD05-265-XP25-SP07-02	▲	26.5	25	32	136	156	56	212	SPMX07T308- XM/LM/EM/XR	I60M2.5×6.5	WT07IP
ZSD05-265-XP32-SP07-02	▲	26.5	32	37	136	156	60	216	SPMX07T308- XM/LM/EM/XR	I60M2.5×6.5	WT07IP
ZSD05-270-XP25-SP07-02	▲	27.0	25	32	138	158	56	214	SPMX07T308- XM/LM/EM/XR	I60M2.5×6.5	WT07IP
ZSD05-270-XP32-SP07-02	▲	27.0	32	37	138	158	60	218	SPMX07T308- XM/LM/EM/XR	I60M2.5×6.5	WT07IP
ZSD05-275-XP25-SP07-02	▲	27.5	25	32	141	161	56	217	SPMX07T308- XM/LM/EM/XR	I60M2.5×6.5	WT07IP
ZSD05-275-XP32-SP07-02	▲	27.5	32	37	141	161	60	221	SPMX07T308- XM/LM/EM/XR	I60M2.5×6.5	WT07IP
ZSD05-280-XP32-SP09-02	▲	28.0	32	37	143	163	60	223	SPMX090408- XM/LM/EM/XR	I60M3.5×8	WT15IP
ZSD05-285-XP32-SP09-02	▲	28.5	32	37	146	166	60	226	SPMX090408- XM/LM/EM/XR	I60M3.5×8	WT15IP
ZSD05-290-XP32-SP09-02	▲	29.0	32	37	148	168	60	228	SPMX090408- XM/LM/EM/XR	I60M3.5×8	WT15IP
ZSD05-295-XP32-SP09-02	▲	29.5	32	37	151	171	60	231	SPMX090408- XM/LM/EM/XR	I60M3.5×8	WT15IP
ZSD05-300-XP32-SP09-02	▲	30.0	32	37	153	173	60	233	SPMX090408- XM/LM/EM/XR	I60M3.5×8	WT15IP
ZSD05-305-XP32-SP09-02	▲	30.5	32	37	156	176	60	236	SPMX090408- XM/LM/EM/XR	I60M3.5×8	WT15IP
ZSD05-310-XP32-SP09-02	▲	31.0	32	37	158	178	60	238	SPMX090408- XM/LM/EM/XR	I60M3.5×8	WT15IP
ZSD05-315-XP32-SP09-02	▲	31.5	32	37	161	181	60	241	SPMX090408- XM/LM/EM/XR	I60M3.5×8	WT15IP
ZSD05-320-XP32-SP09-02	▲	32.0	32	37	163	183	60	243	SPMX090408- XM/LM/EM/XR	I60M3.5×8	WT15IP
ZSD05-320-XP40-SP09-02	▲	32.0	40	47	163	183	70	253	SPMX090408- XM/LM/EM/XR	I60M3.5×8	WT15IP
ZSD05-325-XP32-SP09-02	▲	32.5	32	37	166	186	60	246	SPMX090408- XM/LM/EM/XR	I60M3.5×8	WT15IP
ZSD05-325-XP40-SP09-02	▲	32.5	40	47	166	186	70	256	SPMX090408- XM/LM/EM/XR	I60M3.5×8	WT15IP
ZSD05-330-XP32-SP09-02	▲	33.0	32	37	168	189	60	249	SPMX090408- XM/LM/EM/XR	I60M3.5×8	WT15IP
ZSD05-330-XP40-SP09-02	▲	33.0	40	47	168	189	70	259	SPMX090408- XM/LM/EM/XR	I60M3.5×8	WT15IP
ZSD05-335-XP32-SP09-02	▲	33.5	32	37	171	193	60	253	SPMX090408- XM/LM/EM/XR	I60M3.5×8	WT15IP
ZSD05-335-XP40-SP09-02	▲	33.5	40	47	171	193	70	263	SPMX090408- XM/LM/EM/XR	I60M3.5×8	WT15IP
ZSD05-340-XP40-SP11-02	▲	34.0	40	47	173	198	70	268	SPMX110408- XM/LM/EM/XR	I60M4×10	WT15IP
ZSD05-345-XP40-SP11-02	△	34.5	40	47	176	201	70	271	SPMX110408- XM/LM/EM/XR	I60M4×10	WT15IP
ZSD05-350-XP40-SP11-02	▲	35.0	40	47	178	203	70	273	SPMX110408- XM/LM/EM/XR	I60M4×10	WT15IP
ZSD05-355-XP40-SP11-02	△	35.5	40	47	181	206	70	276	SPMX110408- XM/LM/EM/XR	I60M4×10	WT15IP
ZSD05-360-XP40-SP11-02	▲	36.0	40	47	183	208	70	278	SPMX110408- XM/LM/EM/XR	I60M4×10	WT15IP
ZSD05-365-XP40-SP11-02	△	36.5	40	47	186	211	70	281	SPMX110408- XM/LM/EM/XR	I60M4×10	WT15IP
ZSD05-370-XP40-SP11-02	▲	37.0	40	47	188	213	70	283	SPMX110408- XM/LM/EM/XR	I60M4×10	WT15IP
ZSD05-375-XP40-SP11-02	△	37.5	40	47	191	216	70	286	SPMX110408- XM/LM/EM/XR	I60M4×10	WT15IP
ZSD05-380-XP40-SP11-02	▲	38.0	40	47	193	218	70	288	SPMX110408- XM/LM/EM/XR	I60M4×10	WT15IP
ZSD05-385-XP40-SP11-02	△	38.5	40	47	196	221	70	291	SPMX110408- XM/LM/EM/XR	I60M4×10	WT15IP
ZSD05-390-XP40-SP11-02	▲	39.0	40	47	198	223	70	293	SPMX110408- XM/LM/EM/XR	I60M4×10	WT15IP
ZSD05-395-XP40-SP11-02	△	39.5	40	47	201	226	70	296	SPMX110408- XM/LM/EM/XR	I60M4×10	WT15IP
ZSD05-400-XP40-SP11-02	▲	40.0	40	47	203	228	70	298	SPMX110408- XM/LM/EM/XR	I60M4×10	WT15IP
ZSD05-405-XP40-SP11-02	△	40.5	40	47	206	231	70	301	SPMX110408- XM/LM/EM/XR	I60M4×10	WT15IP
ZSD05-410-XP40-SP11-02	▲	41.0	40	47	208	233	70	303	SPMX110408- XM/LM/EM/XR	I60M4×10	WT15IP
ZSD05-415-XP40-SP11-02	△	41.5	40	47	211	236	70	306	SPMX110408- XM/LM/EM/XR	I60M4×10	WT15IP
ZSD05-420-XP40-SP11-02	▲	42.0	40	52	213	245	70	315	SPMX110408- XM/LM/EM/XR	I60M4×10	WT15IP
ZSD05-420-XP50-SP11-02	△	42.0	50	57	213	245	80	325	SPMX110408- XM/LM/EM/XR	I60M4×10	WT15IP
ZSD05-425-XP40-SP14-02	△	42.5	40	52	216	248	70	318	SPMX140512- XM/LM/EM/XR	I60M5×13	WT20IP

▲Stock available △Make-to-order

Drilling tools

U drills



U drills

U drills

ZSD05 5D

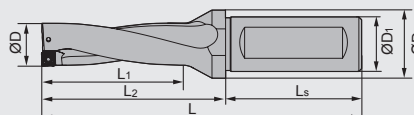

Type	Stock	Basic dimension(mm)							Applicable inserts	Insert screw	Wrench
		ØD	ØD ₁	ØD ₂	L ₁	L ₂	L _s	L			
ZSD05-425-XP50-SP14-02	△	42.5	50	57	216	248	80	328	SPMX140512-XM/LM/EM/XR	I60M5×13	WT201P
ZSD05-430-XP40-SP14-02	▲	43.0	40	52	218	250	70	320	SPMX140512-XM/LM/EM/XR	I60M5×13	WT201P
ZSD05-430-XP50-SP14-02	△	43.0	50	57	218	250	80	330	SPMX140512-XM/LM/EM/XR	I60M5×13	WT201P
ZSD05-435-XP40-SP14-02	△	43.5	40	52	221	253	70	323	SPMX140512-XM/LM/EM/XR	I60M5×13	WT201P
ZSD05-435-XP50-SP14-02	△	43.5	50	57	221	253	80	333	SPMX140512-XM/LM/EM/XR	I60M5×13	WT201P
ZSD05-440-XP40-SP14-02	▲	44.0	40	52	223	255	70	325	SPMX140512-XM/LM/EM/XR	I60M5×13	WT201P
ZSD05-440-XP50-SP14-02	△	44.0	50	57	223	255	80	335	SPMX140512-XM/LM/EM/XR	I60M5×13	WT201P
ZSD05-445-XP40-SP14-02	△	44.5	40	52	226	258	70	328	SPMX140512-XM/LM/EM/XR	I60M5×13	WT201P
ZSD05-445-XP50-SP14-02	△	45.5	50	57	226	258	80	338	SPMX140512-XM/LM/EM/XR	I60M5×13	WT201P
ZSD05-450-XP40-SP14-02	▲	45.0	40	52	228	260	70	330	SPMX140512-XM/LM/EM/XR	I60M5×13	WT201P
ZSD05-450-XP50-SP14-02	△	45.0	50	57	228	260	80	340	SPMX140512-XM/LM/EM/XR	I60M5×13	WT201P
ZSD05-455-XP40-SP14-02	△	45.5	40	52	231	263	70	333	SPMX140512-XM/LM/EM/XR	I60M5×13	WT201P
ZSD05-455-XP50-SP14-02	△	45.5	50	57	231	263	80	343	SPMX140512-XM/LM/EM/XR	I60M5×13	WT201P
ZSD05-460-XP40-SP14-02	▲	46.0	40	52	233	265	70	335	SPMX140512-XM/LM/EM/XR	I60M5×13	WT201P
ZSD05-460-XP50-SP14-02	△	46.0	50	57	233	265	80	345	SPMX140512-XM/LM/EM/XR	I60M5×13	WT201P
ZSD05-465-XP40-SP14-02	△	46.5	40	52	236	268	70	338	SPMX140512-XM/LM/EM/XR	I60M5×13	WT201P
ZSD05-465-XP50-SP14-02	△	46.5	50	57	236	268	80	348	SPMX140512-XM/LM/EM/XR	I60M5×13	WT201P
ZSD05-470-XP40-SP14-02	▲	47.0	40	52	238	270	70	340	SPMX140512-XM/LM/EM/XR	I60M5×13	WT201P
ZSD05-470-XP50-SP14-02	△	47.0	50	57	238	270	80	350	SPMX140512-XM/LM/EM/XR	I60M5×13	WT201P
ZSD05-475-XP40-SP14-02	△	47.5	40	52	241	273	70	343	SPMX140512-XM/LM/EM/XR	I60M5×13	WT201P
ZSD05-475-XP50-SP14-02	△	47.5	50	57	241	273	80	353	SPMX140512-XM/LM/EM/XR	I60M5×13	WT201P
ZSD05-480-XP40-SP14-02	▲	48.0	40	52	243	275	70	345	SPMX140512-XM/LM/EM/XR	I60M5×13	WT201P
ZSD05-480-XP50-SP14-02	△	48.0	50	57	246	275	80	355	SPMX140512-XM/LM/EM/XR	I60M5×13	WT201P
ZSD05-485-XP40-SP14-02	△	48.5	40	52	246	278	70	348	SPMX140512-XM/LM/EM/XR	I60M5×13	WT201P
ZSD05-485-XP50-SP14-02	△	48.5	50	57	246	278	80	358	SPMX140512-XM/LM/EM/XR	I60M5×13	WT201P
ZSD05-490-XP40-SP14-02	▲	49.0	40	52	248	280	70	350	SPMX140512-XM/LM/EM/XR	I60M5×13	WT201P
ZSD05-490-XP50-SP14-02	△	49.0	50	57	248	280	80	360	SPMX140512-XM/LM/EM/XR	I60M5×13	WT201P
ZSD05-495-XP40-SP14-02	△	49.5	40	52	251	283	70	353	SPMX140512-XM/LM/EM/XR	I60M5×13	WT201P
ZSD05-495-XP50-SP14-02	△	49.5	50	57	251	283	80	363	SPMX140512-XM/LM/EM/XR	I60M5×13	WT201P
ZSD05-500-XP40-SP14-02	▲	50.0	40	52	253	285	70	355	SPMX140512-XM/LM/EM/XR	I60M5×13	WT201P
ZSD05-500-XP50-SP14-02	△	50.0	50	57	253	285	80	365	SPMX140512-XM/LM/EM/XR	I60M5×13	WT201P

▲Stock available △Make-to-order

Drilling tools

U drills

Silver fox -New indexable drills for shallow holes

1 Internal coolant hose connector, which is used in lathe.

2 New tool body material with greatly improved tool rigidity.

3 Tool body with specially treated coating for superior lubricating performance.

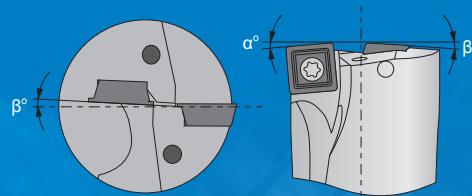

*Innovative technology
fully upgrading*

Optimized flutes and double spiraled internal coolant holes for high efficient drilling.

4 Optimized structure for better chip breaking, lower vibration during cutting, higher machining precision.

5 Extremely large chip pocket, innovative liquid angle, for smoother chip evacuation.

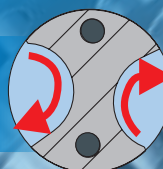

Case

Tool applied: ZTD04-260-XP25-SP07-02
 Insert applied: SPGT07T308-PM /YBG205(Peripheral edge)
 SPGT07T308-PM /YBG212(Inner edge)
 Workpiece material: 50Mn(HB240)
 Cooling system: Double helical internal cooling
 Cutting parameters: $V_c=130\text{m/min}$; $f=210\text{mm/min}$; $a_p=90\text{mm}$



Machining situation

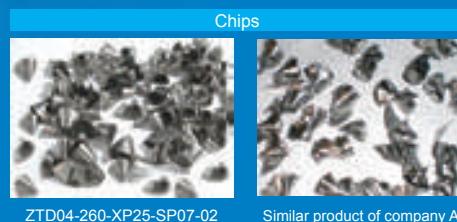
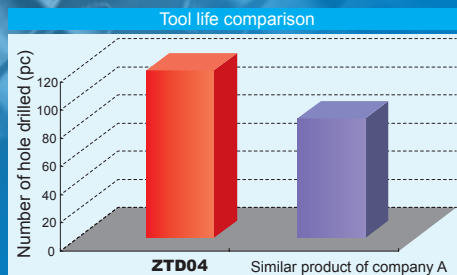

ZTD04-260-XP25-SP07-02

Similar product of company A

- Optimized cutting edge design ensures more stable cutting and better chip breaking.
- Meeting the requirements of central edge and peripheral edge with economy and efficiency.
- Perfect combination of grade and chipbreaker solves all your difficulties in machining.



Inner edge insert



YBG212

- Special coating technology makes insert surface smooth, reducing friction and ensuring unobstructed chip flow.
- Unique nano coating, stronger combination of substrate and highly wear-resistant TiAlN coating, higher toughness and hardness.
- Good thermal stability and chemical stability of coating provide more effective protection for the cutting edge.
- Ultra-fine solid carbide substrate with high toughness ensures high strength of cutting edge.



Peripheral edge insert

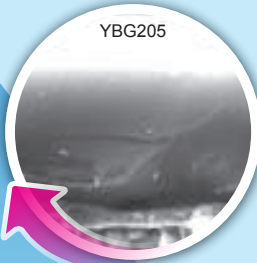

YBG205

- Ultra-fine TiAlN base nano coating added with wear-resistant and heat-resistant rare elements greatly improves over-all properties.
- Special coating technology ensures stronger combination of substrate and coating.
- Thin PVD coating, sharp cutting edge.
- Fine grain WC base solid carbide with high hardness and high toughness.
- Special surface treatment after coating improves surface finish while eliminating harmful stress.

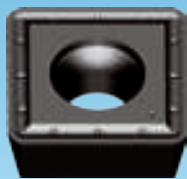

Peripheral edge insert

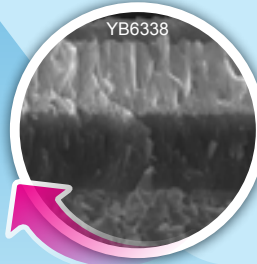



YBG6338

The tool life can increase over 50% for machining P material under steady working condition.

- Substrate of a tough gradient cemented carbide, enriched with surface bonding phase, nano-dioxygen gradient transition layer, and crystal core pre-implantation coating technology, improves the inserts' wear and heat resistance.
- Suitable for high-speed, high-feed, and stable working conditions, it is the first choice for drilling of steel.

Because of the low speed of inner edge and the poor working condition, there is high requirement for insert toughness. Therefore, YBG212 with good over-all properties is recommended for inner edge and YBG205 with high wear resistance for peripheral edge.

Case

Workpiece		Cooling system	Double helical internal cooling	
		Insert applied	SPGT07T308-PM/YBG205	Similar product of company A
Workpiece material	42CrMo (HRC25)	Comparison of insert abrasion (after 15 minutes of machining)		
Cutting parameters	$V_c=150\text{m/min}$ $f_r=0.12\text{mm/r}$ $a_p=80\text{mm}$			



If stationary drilling method is used, the small ejected discs may lead to accidents when workpiece is drilled through, so please see to it that the machine has adequate safety measurements.

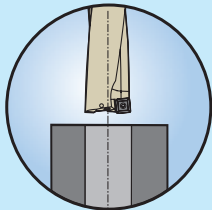
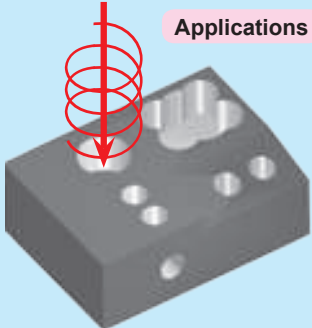

1 Common drilling

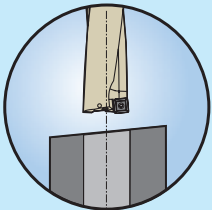

2 inclined face drilling

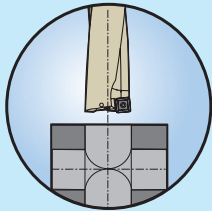

3 Cross-hole drilling

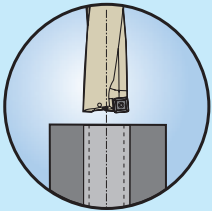

4 Counter boring

Safety information

■ Breakage

Chipping on cutting edges can be caused by various conditions:

- Off-center drill.
- Tool overhang or feed rate is too large.
- Incorrect inserts seating, tip seat was damaged.
- Poor insert stability.
- Insufficient coolant supply.
- Incorrect insert chipbreaker or grade.

■ Insert abrasion

The two most common types of insert abrasion are flank and crater abrasion. The flank abrasion is generally natural abrasion, especially on the peripheral insert which is applied with higher cutting speed. However, this abrasion will finally result that the insert cutting edge cannot achieve the tolerance and/or surface quality required for the machining.

In drilling operations, if flank and crater abrasion exceed certain values, the inserts should be changed without delay for production security.

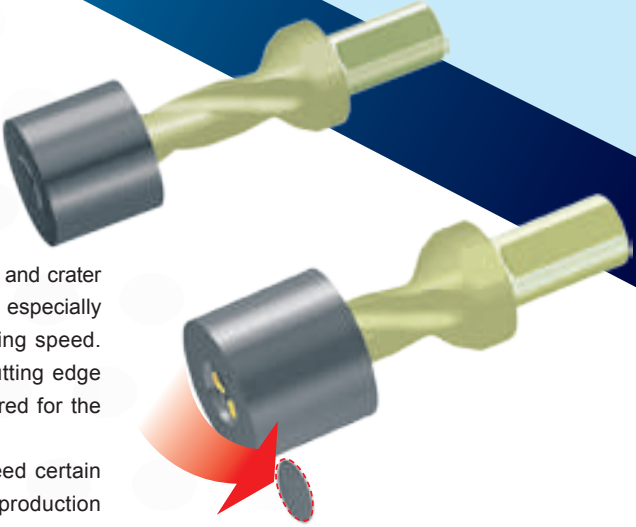



U drills

U drills

ZTD02 2D

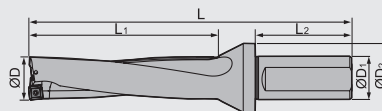

Type	Stock	Basic dimension(mm)						Applicable inserts	Insert screw	Wrench
		ØD	ØD ₁	ØD ₂	L ₁	L ₂	L			
ZTD02-130-XP20-SP04-02	▲	13	20	25	31	50	98	SPGT04T102-PM/EM	I60M1.8×4	WT05IP
ZTD02-140-XP20-SP04-02	▲	14	20	25	33	50	100	SPGT04T102-PM/EM	I60M1.8×4	WT05IP
ZTD02-150-XP20-SP05-02	▲	15	20	25	35	50	102	SPGT050204-PM/EM	I60M2×4.3	WT06P
ZTD02-160-XP20-SP05-02	▲	16	20	25	37	50	104	SPGT050204-PM/EM	I60M2×4.3	WT06P
ZTD02-170-XP25-SP05-02	▲	17	25	32	39	56	117	SPGT050204-PM/EM	I60M2×4.3	WT06P
ZTD02-180-XP25-SP06-02	▲	18	25	32	41	56	119	SPGT060204-PM/EM	I60M2.2×5.5	WT07IP
ZTD02-190-XP25-SP06-02	▲	19	25	32	43	56	121	SPGT060204-PM/EM	I60M2.2×5.5	WT07IP
ZTD02-200-XP25-SP06-02	▲	20	25	32	45	56	123	SPGT060204-PM/EM	I60M2.2×5.5	WT07IP
ZTD02-210-XP25-SP06-02	▲	21	25	32	47	56	125	SPGT060204-PM/EM	I60M2.2×5.5	WT07IP
ZTD02-220-XP25-SP07-02	▲	22	25	32	49	56	127	SPGT07T308-PM/EM	I60M2.5×6.5	WT07IP
ZTD02-230-XP25-SP07-02	▲	23	25	32	51	56	129	SPGT07T308-PM/EM	I60M2.5×6.5	WT07IP
ZTD02-240-XP25-SP07-02	▲	24	25	32	53	56	131	SPGT07T308-PM/EM	I60M2.5×6.5	WT07IP
ZTD02-250-XP25-SP07-02	▲	25	25	32	55	56	133	SPGT07T308-PM/EM	I60M2.5×6.5	WT07IP
ZTD02-260-XP25-SP07-02	▲	26	25	32	57	56	135	SPGT07T308-PM/EM	I60M2.5×6.5	WT07IP
ZTD02-270-XP25-SP07-02	▲	27	25	32	59	56	137	SPGT07T308-PM/EM	I60M2.5×6.5	WT07IP
ZTD02-280-XP32-SP09-02	▲	28	32	37	61	60	146	SPGT090408-PM/EM	I60M3.5×8	WT15IP
ZTD02-290-XP32-SP09-02	▲	29	32	37	63	60	148	SPGT090408-PM/EM	I60M3.5×8	WT15IP
ZTD02-300-XP32-SP09-02	▲	30	32	37	65	60	150	SPGT090408-PM/EM	I60M3.5×8	WT15IP
ZTD02-310-XP32-SP09-02	▲	31	32	37	67	60	152	SPGT090408-PM/EM	I60M3.5×8	WT15IP
ZTD02-320-XP32-SP09-02	▲	32	32	37	69	60	154	SPGT090408-PM/EM	I60M3.5×8	WT15IP
ZTD02-330-XP32-SP09-02	▲	33	32	37	71	60	156	SPGT090408-PM/EM	I60M3.5×8	WT15IP
ZTD02-340-XP40-SP11-02	▲	34	40	47	73	70	173	SPGT110408-PM/EM	I60M4×10	WT15IP
ZTD02-350-XP40-SP11-02	▲	35	40	47	75	70	175	SPGT110408-PM/EM	I60M4×10	WT15IP
ZTD02-360-XP40-SP11-02	▲	36	40	47	77	70	177	SPGT110408-PM/EM	I60M4×10	WT15IP
ZTD02-370-XP40-SP11-02	▲	37	40	47	79	70	179	SPGT110408-PM/EM	I60M4×10	WT15IP
ZTD02-380-XP40-SP11-02	▲	38	40	47	81	70	181	SPGT110408-PM/EM	I60M4×10	WT15IP
ZTD02-390-XP40-SP11-02	▲	39	40	47	83	70	183	SPGT110408-PM/EM	I60M4×10	WT15IP
ZTD02-400-XP40-SP11-02	▲	40	40	47	85	70	185	SPGT110408-PM/EM	I60M4×10	WT15IP
ZTD02-410-XP40-SP11-02	▲	41	40	47	87	70	187	SPGT110408-PM/EM	I60M4×10	WT15IP
ZTD02-420-XP40-SP14-02	△	42	40	52	89	70	199	SPGT140512-PM/EM	I60M5×13	WT20IP
ZTD02-430-XP40-SP14-02	△	43	40	52	91	70	201	SPGT140512-PM/EM	I60M5×13	WT20IP
ZTD02-440-XP40-SP14-02	△	44	40	52	93	70	203	SPGT140512-PM/EM	I60M5×13	WT20IP
ZTD02-450-XP40-SP14-02	△	45	40	52	95	70	205	SPGT140512-PM/EM	I60M5×13	WT20IP
ZTD02-460-XP40-SP14-02	△	46	40	52	97	70	207	SPGT140512-PM/EM	I60M5×13	WT20IP
ZTD02-470-XP40-SP14-02	△	47	40	52	99	70	209	SPGT140512-PM/EM	I60M5×13	WT20IP
ZTD02-480-XP40-SP14-02	△	48	40	52	101	70	211	SPGT140512-PM/EM	I60M5×13	WT20IP
ZTD02-490-XP40-SP14-02	△	49	40	52	103	70	213	SPGT140512-PM/EM	I60M5×13	WT20IP
ZTD02-500-XP40-SP14-02	△	50	40	52	105	70	215	SPGT140512-PM/EM	I60M5×13	WT20IP

▲Stock available △Make-to-order

Drilling tools

U drills



U drills

ZTD03 3D

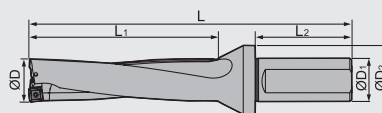

Type	Stock	Basic dimension(mm)						Applicable inserts	Insert screw	Wrench
		ØD	ØD ₁	ØD ₂	L ₁	L ₂	L			
ZTD03-130-XP20-SP04-02	▲	13	20	25	44	50	111	SPGT04T102-PM/EM	I60M1.8×4	WT05IP
ZTD03-140-XP20-SP04-02	▲	14	20	25	47	50	114	SPGT04T102-PM/EM	I60M1.8×4	WT05IP
ZTD03-150-XP20-SP05-02	▲	15	20	25	50	50	117	SPGT050204-PM/EM	I60M2×4.3	WT06P
ZTD03-160-XP20-SP05-02	▲	16	20	25	53	50	120	SPGT050204-PM/EM	I60M2×4.3	WT06P
ZTD03-170-XP25-SP05-02	▲	17	25	32	56	56	134	SPGT050204-PM/EM	I60M2×4.3	WT06P
ZTD03-180-XP25-SP06-02	▲	18	25	32	59	56	137	SPGT060204-PM/EM	I60M2.2×5.5	WT07IP
ZTD03-190-XP25-SP06-02	▲	19	25	32	62	56	140	SPGT060204-PM/EM	I60M2.2×5.5	WT07IP
ZTD03-200-XP25-SP06-02	▲	20	25	32	65	56	143	SPGT060204-PM/EM	I60M2.2×5.5	WT07IP
ZTD03-210-XP25-SP06-02	▲	21	25	32	68	56	146	SPGT060204-PM/EM	I60M2.2×5.5	WT07IP
ZTD03-220-XP25-SP07-02	▲	22	25	32	71	56	149	SPGT07T308-PM/EM	I60M2.5×6.5	WT07IP
ZTD03-230-XP25-SP07-02	▲	23	25	32	74	56	152	SPGT07T308-PM/EM	I60M2.5×6.5	WT07IP
ZTD03-240-XP25-SP07-02	▲	24	25	32	77	56	155	SPGT07T308-PM/EM	I60M2.5×6.5	WT07IP
ZTD03-250-XP25-SP07-02	▲	25	25	32	80	56	158	SPGT07T308-PM/EM	I60M2.5×6.5	WT07IP
ZTD03-260-XP25-SP07-02	▲	26	25	32	83	56	161	SPGT07T308-PM/EM	I60M2.5×6.5	WT07IP
ZTD03-270-XP25-SP07-02	▲	27	25	32	86	56	164	SPGT07T308-PM/EM	I60M2.5×6.5	WT07IP
ZTD03-280-XP32-SP09-02	▲	28	32	37	89	60	174	SPGT090408-PM/EM	I60M3.5×8	WT15IP
ZTD03-290-XP32-SP09-02	▲	29	32	37	92	60	177	SPGT090408-PM/EM	I60M3.5×8	WT15IP
ZTD03-300-XP32-SP09-02	▲	30	32	37	95	60	180	SPGT090408-PM/EM	I60M3.5×8	WT15IP
ZTD03-310-XP32-SP09-02	▲	31	32	37	98	60	183	SPGT090408-PM/EM	I60M3.5×8	WT15IP
ZTD03-320-XP32-SP09-02	▲	32	32	37	101	60	186	SPGT090408-PM/EM	I60M3.5×8	WT15IP
ZTD03-330-XP32-SP09-02	▲	33	32	37	104	60	189	SPGT090408-PM/EM	I60M3.5×8	WT15IP
ZTD03-340-XP40-SP11-02	▲	34	40	47	107	70	207	SPGT110408-PM/EM	I60M4×10	WT15IP
ZTD03-350-XP40-SP11-02	▲	35	40	47	110	70	210	SPGT110408-PM/EM	I60M4×10	WT15IP
ZTD03-360-XP40-SP11-02	▲	36	40	47	113	70	213	SPGT110408-PM/EM	I60M4×10	WT15IP
ZTD03-370-XP40-SP11-02	▲	37	40	47	116	70	216	SPGT110408-PM/EM	I60M4×10	WT15IP
ZTD03-380-XP40-SP11-02	▲	38	40	47	119	70	219	SPGT110408-PM/EM	I60M4×10	WT15IP
ZTD03-390-XP40-SP11-02	▲	39	40	47	122	70	222	SPGT110408-PM/EM	I60M4×10	WT15IP
ZTD03-400-XP40-SP11-02	▲	40	40	47	125	70	225	SPGT110408-PM/EM	I60M4×10	WT15IP
ZTD03-410-XP40-SP11-02	▲	41	40	47	128	70	228	SPGT110408-PM/EM	I60M4×10	WT15IP
ZTD03-420-XP40-SP14-02	△	42	40	52	131	70	241	SPGT140512-PM/EM	I60M5×13	WT20IP
ZTD03-430-XP40-SP14-02	△	43	40	52	134	70	244	SPGT140512-PM/EM	I60M5×13	WT20IP
ZTD03-440-XP40-SP14-02	△	44	40	52	137	70	247	SPGT140512-PM/EM	I60M5×13	WT20IP
ZTD03-450-XP40-SP14-02	△	45	40	52	140	70	250	SPGT140512-PM/EM	I60M5×13	WT20IP
ZTD03-460-XP40-SP14-02	△	46	40	52	143	70	253	SPGT140512-PM/EM	I60M5×13	WT20IP
ZTD03-470-XP40-SP14-02	△	47	40	52	146	70	256	SPGT140512-PM/EM	I60M5×13	WT20IP
ZTD03-480-XP40-SP14-02	△	48	40	52	149	70	259	SPGT140512-PM/EM	I60M5×13	WT20IP
ZTD03-490-XP40-SP14-02	△	49	40	52	152	70	262	SPGT140512-PM/EM	I60M5×13	WT20IP
ZTD03-500-XP40-SP14-02	△	50	40	52	155	70	265	SPGT140512-PM/EM	I60M5×13	WT20IP

▲Stock available △Make-to-order

Drilling tools

U drills



U drills

U drills

ZTD04 4D

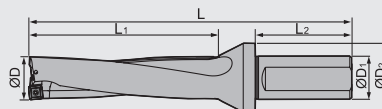

Type	Stock	Basic dimension(mm)						Applicable inserts	Insert screw	Wrench
		ØD	ØD ₁	ØD ₂	L ₁	L ₂	L			
ZTD04-130-XP20-SP04-02	▲	13	20	25	57	50	124	SPGT04T102-PM/EM	I60M1.8×4	WT05IP
ZTD04-140-XP20-SP04-02	▲	14	20	25	61	50	128	SPGT04T102-PM/EM	I60M1.8×4	WT05IP
ZTD04-150-XP20-SP05-02	▲	15	20	25	65	50	132	SPGT050204-PM/EM	I60M2×4.3	WT06P
ZTD04-160-XP20-SP05-02	▲	16	20	25	69	50	136	SPGT050204-PM/EM	I60M2×4.3	WT06P
ZTD04-170-XP25-SP05-02	▲	17	25	32	73	56	151	SPGT050204-PM/EM	I60M2×4.3	WT06P
ZTD04-180-XP25-SP06-02	▲	18	25	32	77	56	155	SPGT060204-PM/EM	I60M2.2×5.5	WT07IP
ZTD04-190-XP25-SP06-02	▲	19	25	32	81	56	159	SPGT060204-PM/EM	I60M2.2×5.5	WT07IP
ZTD04-200-XP25-SP06-02	▲	20	25	32	85	56	163	SPGT060204-PM/EM	I60M2.2×5.5	WT07IP
ZTD04-210-XP25-SP06-02	▲	21	25	32	89	56	167	SPGT060204-PM/EM	I60M2.2×5.5	WT07IP
ZTD04-220-XP25-SP07-02	▲	22	25	32	93	56	171	SPGT07T308-PM/EM	I60M2.5×6.5	WT07IP
ZTD04-230-XP25-SP07-02	▲	23	25	32	97	56	175	SPGT07T308-PM/EM	I60M2.5×6.5	WT07IP
ZTD04-240-XP25-SP07-02	▲	24	25	32	101	56	179	SPGT07T308-PM/EM	I60M2.5×6.5	WT07IP
ZTD04-250-XP25-SP07-02	▲	25	25	32	105	56	183	SPGT07T308-PM/EM	I60M2.5×6.5	WT07IP
ZTD04-260-XP25-SP07-02	▲	26	25	32	109	56	187	SPGT07T308-PM/EM	I60M2.5×6.5	WT07IP
ZTD04-270-XP25-SP07-02	▲	27	25	32	113	56	191	SPGT07T308-PM/EM	I60M2.5×6.5	WT07IP
ZTD04-280-XP32-SP09-02	▲	28	32	37	117	60	202	SPGT090408-PM/EM	I60M3.5×8	WT15IP
ZTD04-290-XP32-SP09-02	▲	29	32	37	121	60	206	SPGT090408-PM/EM	I60M3.5×8	WT15IP
ZTD04-300-XP32-SP09-02	▲	30	32	37	125	60	210	SPGT090408-PM/EM	I60M3.5×8	WT15IP
ZTD04-310-XP32-SP09-02	▲	31	32	37	129	60	214	SPGT090408-PM/EM	I60M3.5×8	WT15IP
ZTD04-320-XP32-SP09-02	▲	32	32	37	133	60	218	SPGT090408-PM/EM	I60M3.5×8	WT15IP
ZTD04-330-XP32-SP09-02	▲	33	32	37	137	60	222	SPGT090408-PM/EM	I60M3.5×8	WT15IP
ZTD04-340-XP40-SP11-02	▲	34	40	47	141	70	241	SPGT110408-PM/EM	I60M4×10	WT15IP
ZTD04-350-XP40-SP11-02	▲	35	40	47	145	70	245	SPGT110408-PM/EM	I60M4×10	WT15IP
ZTD04-360-XP40-SP11-02	▲	36	40	47	149	70	249	SPGT110408-PM/EM	I60M4×10	WT15IP
ZTD04-370-XP40-SP11-02	▲	37	40	47	153	70	253	SPGT110408-PM/EM	I60M4×10	WT15IP
ZTD04-380-XP40-SP11-02	▲	38	40	47	157	70	257	SPGT110408-PM/EM	I60M4×10	WT15IP
ZTD04-390-XP40-SP11-02	▲	39	40	47	161	70	261	SPGT110408-PM/EM	I60M4×10	WT15IP
ZTD04-400-XP40-SP11-02	▲	40	40	47	165	70	265	SPGT110408-PM/EM	I60M4×10	WT15IP
ZTD04-410-XP40-SP11-02	▲	41	40	47	169	70	269	SPGT110408-PM/EM	I60M4×10	WT15IP
ZTD04-420-XP40-SP14-02	△	42	40	52	173	70	283	SPGT140512-PM/EM	I60M5×13	WT20IP
ZTD04-430-XP40-SP14-02	△	43	40	52	177	70	287	SPGT140512-PM/EM	I60M5×13	WT20IP
ZTD04-440-XP40-SP14-02	△	44	40	52	181	70	291	SPGT140512-PM/EM	I60M5×13	WT20IP
ZTD04-450-XP40-SP14-02	△	45	40	52	185	70	295	SPGT140512-PM/EM	I60M5×13	WT20IP
ZTD04-460-XP40-SP14-02	△	46	40	52	189	70	299	SPGT140512-PM/EM	I60M5×13	WT20IP
ZTD04-470-XP40-SP14-02	△	47	40	52	193	70	303	SPGT140512-PM/EM	I60M5×13	WT20IP
ZTD04-480-XP40-SP14-02	△	48	40	52	197	70	307	SPGT140512-PM/EM	I60M5×13	WT20IP
ZTD04-490-XP40-SP14-02	△	49	40	52	201	70	311	SPGT140512-PM/EM	I60M5×13	WT20IP
ZTD04-500-XP40-SP14-02	△	50	40	52	205	70	315	SPGT140512-PM/EM	I60M5×13	WT20IP

▲Stock available △Make-to-order

Drilling tools

U drills



U drills

ZTD05 5D

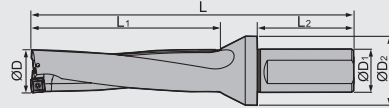

Type	Stock	Basic dimension(mm)						Applicable inserts	Insert screw	Wrench
		ØD	ØD1	ØD2	L1	L2	L			
ZTD05-130-XP20-SP04-02	▲	13	20	25	70	50	137	SPGT04T102-PM/EM	I60M1.8×4	WT05IP
ZTD05-140-XP20-SP04-02	▲	14	20	25	75	50	142	SPGT04T102-PM/EM	I60M1.8×4	WT05IP
ZTD05-150-XP20-SP05-02	▲	15	20	25	80	50	147	SPGT050204-PM/EM	I60M2×4.3	WT06P
ZTD05-160-XP20-SP05-02	▲	16	20	25	85	50	152	SPGT050204-PM/EM	I60M2×4.3	WT06P
ZTD05-170-XP25-SP05-02	▲	17	25	32	90	56	168	SPGT050204-PM/EM	I60M2×4.3	WT06P
ZTD05-180-XP25-SP06-02	▲	18	25	32	95	56	173	SPGT060204-PM/EM	I60M2.2×5.5	WT07IP
ZTD05-190-XP25-SP06-02	▲	19	25	32	100	56	178	SPGT060204-PM/EM	I60M2.2×5.5	WT07IP
ZTD05-200-XP25-SP06-02	▲	20	25	32	105	56	183	SPGT060204-PM/EM	I60M2.2×5.5	WT07IP
ZTD05-210-XP25-SP06-02	▲	21	25	32	110	56	188	SPGT060204-PM/EM	I60M2.2×5.5	WT07IP
ZTD05-220-XP25-SP07-02	▲	22	25	32	115	56	193	SPGT07T308-PM/EM	I60M2.5×6.5	WT07IP
ZTD05-230-XP25-SP07-02	▲	23	25	32	120	56	198	SPGT07T308-PM/EM	I60M2.5×6.5	WT07IP
ZTD05-240-XP25-SP07-02	▲	24	25	32	125	56	203	SPGT07T308-PM/EM	I60M2.5×6.5	WT07IP
ZTD05-250-XP25-SP07-02	▲	25	25	32	130	56	208	SPGT07T308-PM/EM	I60M2.5×6.5	WT07IP
ZTD05-260-XP25-SP07-02	▲	26	25	32	135	56	213	SPGT07T308-PM/EM	I60M2.5×6.5	WT07IP
ZTD05-270-XP25-SP07-02	▲	27	25	32	140	56	218	SPGT07T308-PM/EM	I60M2.5×6.5	WT07IP
ZTD05-280-XP32-SP09-02	▲	28	32	37	145	60	230	SPGT090408-PM/EM	I60M3.5×8	WT15IP
ZTD05-290-XP32-SP09-02	▲	29	32	37	150	60	235	SPGT090408-PM/EM	I60M3.5×8	WT15IP
ZTD05-300-XP32-SP09-02	▲	30	32	37	155	60	240	SPGT090408-PM/EM	I60M3.5×8	WT15IP
ZTD05-310-XP32-SP09-02	▲	31	32	37	160	60	245	SPGT090408-PM/EM	I60M3.5×8	WT15IP
ZTD05-320-XP32-SP09-02	▲	32	32	37	165	60	250	SPGT090408-PM/EM	I60M3.5×8	WT15IP
ZTD05-330-XP32-SP09-02	▲	33	32	37	170	60	255	SPGT090408-PM/EM	I60M3.5×8	WT15IP
ZTD05-340-XP40-SP11-02	▲	34	40	47	175	70	275	SPGT110408-PM/EM	I60M4×10	WT15IP
ZTD05-350-XP40-SP11-02	▲	35	40	47	180	70	280	SPGT110408-PM/EM	I60M4×10	WT15IP
ZTD05-360-XP40-SP11-02	▲	36	40	47	185	70	285	SPGT110408-PM/EM	I60M4×10	WT15IP
ZTD05-370-XP40-SP11-02	▲	37	40	47	190	70	290	SPGT110408-PM/EM	I60M4×10	WT15IP
ZTD05-380-XP40-SP11-02	▲	38	40	47	195	70	295	SPGT110408-PM/EM	I60M4×10	WT15IP
ZTD05-390-XP40-SP11-02	▲	39	40	47	200	70	300	SPGT110408-PM/EM	I60M4×10	WT15IP
ZTD05-400-XP40-SP11-02	▲	40	40	47	205	70	305	SPGT110408-PM/EM	I60M4×10	WT15IP
ZTD05-410-XP40-SP11-02	▲	41	40	47	210	70	310	SPGT110408-PM/EM	I60M4×10	WT15IP
ZTD05-420-XP40-SP14-02	△	42	40	52	215	70	325	SPGT140512-PM/EM	I60M5×13	WT20IP
ZTD05-430-XP40-SP14-02	△	43	40	52	220	70	330	SPGT140512-PM/EM	I60M5×13	WT20IP
ZTD05-440-XP40-SP14-02	△	44	40	52	225	70	335	SPGT140512-PM/EM	I60M5×13	WT20IP
ZTD05-450-XP40-SP14-02	△	45	40	52	230	70	340	SPGT140512-PM/EM	I60M5×13	WT20IP
ZTD05-460-XP40-SP14-02	△	46	40	52	235	70	345	SPGT140512-PM/EM	I60M5×13	WT20IP
ZTD05-470-XP40-SP14-02	△	47	40	52	240	70	350	SPGT140512-PM/EM	I60M5×13	WT20IP
ZTD05-480-XP40-SP14-02	△	48	40	52	245	70	355	SPGT140512-PM/EM	I60M5×13	WT20IP
ZTD05-490-XP40-SP14-02	△	49	40	52	250	70	360	SPGT140512-PM/EM	I60M5×13	WT20IP
ZTD05-500-XP40-SP14-02	△	50	40	52	255	70	365	SPGT140512-PM/EM	I60M5×13	WT20IP

▲Stock available △Make-to-order

Drilling tools

U drills



BORING TOOL / Drilling Tools

U drills code key

U drills code key

Code	Insert shap
S	
W	

Insert shape / code

Code	Nose Height m Tolerance(mm)	Inscribed Circle ØI.C Tolerance(mm)	Thickness S Tolerance(mm)	Code	Nose Height m Tolerance(mm)	Inscribed Circle ØI.C Tolerance(mm)	Thickness S Tolerance(mm)
A	±0.005	±0.025	±0.025	J	±0.005	±0.05-±0.13	±0.025
F	±0.005	±0.013	±0.025	K	±0.013	±0.05-±0.13	±0.025
C	±0.013	±0.025	±0.025	L	±0.025	±0.05-±0.13	±0.025
H	±0.013	±0.013	±0.025	M	±0.08-±0.18	±0.05-±0.13	±0.13
E	±0.025	±0.025	±0.025	N	±0.08-±0.18	±0.05-±0.13	±0.025
G	±0.025	±0.025	±0.13	U	±0.13-±0.38	±0.08-±0.25	±0.13

Tolerance



Drilling tools

U drills code key

Clearance angle of main cutting edge

Code	Clearance angle	Code	Clearance angle
A	3°	B	5°
C	7°	D	15°
E	20°	F	25°
G	30°	N	0°
P	11°	O	Other clearance angle

Chipbreaker and clamping system

Metric							
Code	With/Without hole	With/Without chipbreaker	Section plane of Insert	Code	With/Without hole	With/Without chipbreaker	Section plane of Insert
B	With	Without	>65°	N	Without	Without	
H	With	Single-side	>65°	R	Without	Single-side	
C	With	Without	>65°	F	Without	Double-side	
J	With	Double-side	>65°	A	With	Without	
W	With	Without	≤65°	M	With	Single-side	
T	With	Single-side	≤65°	G	With	Double-side	
Q	With	Without	≤65°	X	---	---	Special
U	With	Double-side	≤65°				



Code	Length	
	W	S
03	3.8	
04	4.3	
05	5.4	
06	6.5	6.35
08	8.7	8.0
09		9.525
12		12.7

Length of cutting edge

Thickness is defined as the height from the bottom of insert to the highest part of cutting edge.

Code	Insert thickness (mm)	Code	Insert thickness (mm)
00	0.79	05	5.96
T0	0.99	T5	5.95
01	1.59	06	6.35
T1	1.98	T6	6.75
02	2.38	07	7.94
T2	2.58	09	9.52
03	3.18	T9	9.72
T3	3.97	11	11.11
04	4.76	12	12.70
T4	4.96		

Insert thickness

08 04 12 R - PG

Nose radius

Code	Description
04	0.4mm
08	0.8mm
12	1.2mm

Cutting direction

Code	Description
R	Right hand
L	Left hand
N	Neutral

Chipbreaker code

Drilling tools

U drills code key



Indexable inserts for U drills

ZSD applicable inserts

-EM

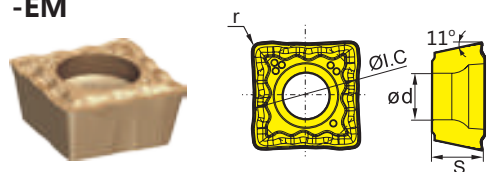

Type	Basic dimension(mm)				CVD grade				PVD grade			
	ØI.C	s	ød	r	YB6338 (Peripheral edge)	YB9315 (Inner/peripheral edge)	YBS203 (Inner/peripheral edge)	YB9320 (Inner/peripheral edge)	YB6338 (Peripheral edge)	YB9315 (Inner/peripheral edge)	YBS203 (Inner/peripheral edge)	YB9320 (Inner/peripheral edge)
SPMX040203-EM	4.0	2.38	2.2	0.3	★	●	●	★	★	●	●	★
SPMX050204-EM	5.0	2.38	2.2	0.4	★	●	●	★	★	●	●	★
SPMX060204-EM	6.0	2.38	2.5	0.4	★	●	●	★	★	●	●	★
SPMX07T308-EM	7.94	3.97	2.8	0.8	★	●	●	★	★	●	●	★
SPMX090408-EM	9.8	4.3	4.1	0.8	★	●	●	★	★	●	●	★
SPMX110408-EM	11.5	4.76	4.4	0.8	★	●	●	★	★	●	●	★
SPMX140512-EM	14.3	5.2	5.5	1.2	★	●	●	★	★	●	●	★

★ Recommended grade (always stock available)

● Available grade (always stock available)

○ Make-to-order

-LM

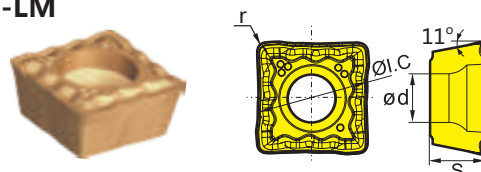

Type	Basic dimension(mm)				CVD grade				PVD grade			
	ØI.C	s	ød	r	YB6338 (Peripheral edge)	YB9315 (Inner/peripheral edge)	YBS203 (Inner/peripheral edge)	YB9320 (Inner/peripheral edge)	YB6338 (Peripheral edge)	YB9315 (Inner/peripheral edge)	YBS203 (Inner/peripheral edge)	YB9320 (Inner/peripheral edge)
SPMX040203-LM	4.0	2.38	2.2	0.3	★	●	●	★	★	●	●	★
SPMX050204-LM	5.0	2.38	2.2	0.4	★	●	●	★	★	●	●	★
SPMX060204-LM	6.0	2.38	2.5	0.4	★	●	●	★	★	●	●	★
SPMX07T308-LM	7.94	3.97	2.8	0.8	★	●	●	★	★	●	●	★
SPMX090408-LM	9.8	4.3	4.1	0.8	★	●	●	★	★	●	●	★
SPMX110408-LM	11.5	4.76	4.4	0.8	★	●	●	★	★	●	●	★
SPMX140512-LM	14.3	5.2	5.5	1.2	★	●	●	★	★	●	●	★

★ Recommended grade (always stock available)

● Available grade (always stock available)

○ Make-to-order

-XM

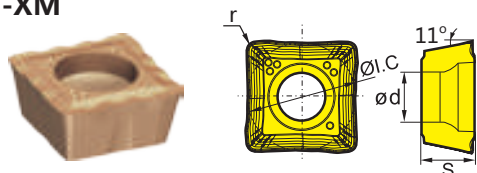

Type	Basic dimension(mm)				CVD grade				PVD grade			
	ØI.C	s	ød	r	YB6338 (Peripheral edge)	YB9315 (Inner/peripheral edge)	YBS203 (Inner/peripheral edge)	YB9320 (Inner/peripheral edge)	YB6338 (Peripheral edge)	YB9315 (Inner/peripheral edge)	YBS203 (Inner/peripheral edge)	YB9320 (Inner/peripheral edge)
SPMX040203-XM	4.0	2.38	2.2	0.3	★	●	●	★	★	●	●	★
SPMX050204-XM	5.0	2.38	2.2	0.4	★	●	●	★	★	●	●	★
SPMX060204-XM	6.0	2.38	2.5	0.4	★	●	●	★	★	●	●	★
SPMX07T308-XM	7.94	3.97	2.8	0.8	★	●	●	★	★	●	●	★
SPMX090408-XM	9.8	4.3	4.1	0.8	★	●	●	★	★	●	●	★
SPMX110408-XM	11.5	4.76	4.4	0.8	★	●	●	★	★	●	●	★
SPMX140512-XM	14.3	5.2	5.5	1.2	★	●	●	★	★	●	●	★

★ Recommended grade (always stock available)

● Available grade (always stock available)

○ Make-to-order

-XR

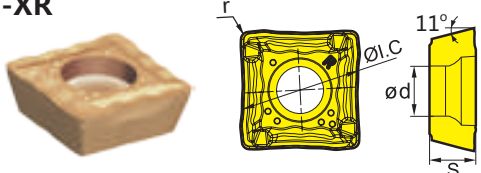

Type	Basic dimension(mm)				CVD grade				PVD grade			
	ØI.C	s	ød	r	YB6338 (Peripheral edge)	YB9315 (Inner/peripheral edge)	YBS203 (Inner/peripheral edge)	YB9320 (Inner/peripheral edge)	YB6338 (Peripheral edge)	YB9315 (Inner/peripheral edge)	YBS203 (Inner/peripheral edge)	YB9320 (Inner/peripheral edge)
SPMX040203-XR	4.0	2.38	2.2	0.3	★	●	●	★	★	●	●	★
SPMX050204-XR	5.0	2.38	2.2	0.4	★	●	●	★	★	●	●	★
SPMX060204-XR	6.0	2.38	2.5	0.4	★	●	●	★	★	●	●	★
SPMX07T308-XR	7.94	3.97	2.8	0.8	★	●	●	★	★	●	●	★
SPMX090408-XR	9.8	4.3	4.1	0.8	★	●	●	★	★	●	●	★
SPMX110408-XR	11.5	4.76	4.4	0.8	★	●	●	★	★	●	●	★
SPMX140512-XR	14.3	5.2	5.5	1.2	★	●	●	★	★	●	●	★

★ Recommended grade (always stock available)

● Available grade (always stock available)

○ Make-to-order



ZTD applicable inserts

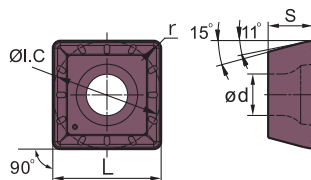

Type	Basic dimension(mm)					Grade		
	L	ØI.C	s	ød	r	YB6338 (peripheral edge)	YBG205 (peripheral edge)	YBG212 (inner edge)
SPGT050204-PM	5	5	2.38	2.2	0.4	★	★	★
SPGT060204-PM	6	6	2.38	2.6	0.4	★	★	★
SPGT07T308-PM	7.94	7.94	3.97	2.8	0.8	★	★	★
SPGT090408-PM	9.8	9.8	4.3	4.2	0.8	★	★	★
SPGT110408-PM	11.5	11.5	4.76	4.4	0.8	★	★	★
SPGT140512-PM	14.3	14.3	5.2	5.75	1.2	★	★	★

★ Recommended grade (always stock available) ● Available grade (always stock available) ○ Make-to-order

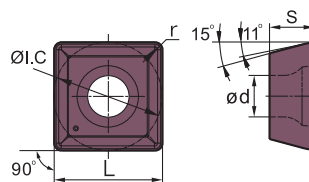

Type	Basic dimension(mm)					Grade		
	L	ØI.C	s	ød	r	YB6338 (peripheral edge)	YBG205 (peripheral edge)	YBG212 (inner edge)
SPGT050204-EM	5	5	2.38	2.2	0.4	★	★	★
SPGT060204-EM	6	6	2.38	2.6	0.4	★	★	★
SPGT07T308-EM	7.94	7.94	3.97	2.8	0.8	★	★	★
SPGT090408-EM	9.8	9.8	4.3	4.2	0.8	★	★	★
SPGT110408-EM	11.5	11.5	4.76	4.4	0.8	★	★	★
SPGT140512-EM	14.3	14.3	5.2	5.75	1.2	★	★	★

★ Recommended grade (always stock available) ● Available grade (always stock available) ○ Make-to-order

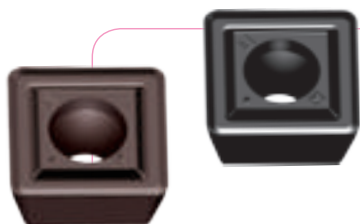

-EM chipbreaker characteristics

Recommended chipbreaker for M kind materials drilling. With G-class accuracy, sharp cutting edges, and high strength, better performance of resist impacts. Inserts meet the required of machining adhesive material, It is also properly suited for machining Austenite Stainless steel etc adhesive materials.



Indexable inserts for U drills

ZTD03 applicable inserts

-53



-PG

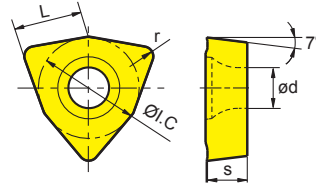

Type	Basic dimension(mm)					Grade	
	L	ØI.C	s	d	r	YBG202	YB6338
WCMX030208R-53	3.8	5.56	2.38	2.8	0.8	★	★
WCMX040208R-53	4.3	6.35	2.38	3.1	0.8	★	★
WCMX050308R-53	5.4	7.94	3.18	3.2	0.8	★	★
WCMX06T308R-53	6.5	9.525	3.97	3.7	0.8	★	★
WCMX080412R-53	8.7	12.7	4.76	4.3	1.2	★	★
WCMX030208R-PG	3.8	5.56	2.38	2.8	0.8	★	●
WCMX040208R-PG	4.3	6.35	2.38	3.1	0.8	★	●
WCMX050308R-PG	5.4	7.94	3.18	3.2	0.8	★	●
WCMX06T308R-PG	6.5	9.525	3.97	3.7	0.8	★	●
WCMX080412R-PG	8.7	12.7	4.76	4.3	1.2	★	●

★ Recommended grade (always stock available) ● Available grade (always stock available) ○ Make-to-order

Drilling tools

Indexable inserts for U drills

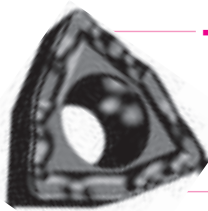

-PG chipbreaker characteristics

Unique design of corrugated edge ensures high edge strength and good chip breaking performance, for machining of carbon steel and alloy steel.



-53 chipbreaker characteristics

Sharp cutting edge beneficial to gaining low roughness surface, mainly applicable for low load cutting of aluminum alloy, mild steel and cast iron.



Initial drill penetration

Initial drill penetration is an important factor for successful drilling. One way of ensuring good hole quality is to make sure the penetration surface of the workpiece is vertical to the drill centre axis. In addition, an indexable drill can carry out initial penetration of convex, concave, inclined and irregular surfaces by adjusting feed rates.

Workpiece surface	Countermeasures
	For a convex surface, the conditions are relatively good and the centre of the drill ideally makes contact with the workpiece first, thus normal feed can be adopted.
	When penetrating an inclined surface, the cutting edges will be unevenly loaded, which may result in the premature drill abrasion. If the angle of the inclined surface is larger than 2°, the feed should be reduced to 1/3 of the value recommended for the drill.
	When drilling into concave surface, drill center axis normally tends to go off-center, the feed should be reduced to 1/3 of the value recommended for the drill.
	When drilling into non-symmetric curved surfaces, the drill tends to deviate from the centre because it is penetrating an inclined surface. The feed should be reduced to lower than the value recommended for the initial penetration of concave surfaces.
	When drilling into irregular surface, the insert faces the risk of chipping, which may also occur when drilling through the workpiece. Therefore, the feed rate should be reduced.

Calculations for shallow drilling

Cutting speed (V_c)

$$V_c = \frac{D_c \times \pi \times n}{1000}$$

V_c (m/min): cutting speed
D_c (mm): drill diameter
n (rev/min): rotating speed

◆ Example

Spindle speed is 1600 rev/min, drill diameter is 20mm, thus cutting speed is:

$$V_c = \frac{D_c \times \pi \times n}{1000} = \frac{20 \times 3.14 \times 1600}{1000} = 100 \text{ (m/min)}$$

Feed speed

$$V_f = f_r \times n \text{ (mm/min)}$$

V_f (mm/min): feed speed
f_r (mm/rev): feed rate per revolution
n (rev/min): spindle speed

◆ Example

Spindle speed is 1500 rev/min, feed rate per revolution is 0.1mm/rev, thus feed speed is:

$$V_f = f_r \times n = 0.1 \times 1500 = 150 \text{ (mm/min)}$$

Machining time

$$T_c = \frac{I_d \times i}{n \times f}$$

T_c (min): machining time
f_r (mm/rev): feed rate per revolution
i: number of holes I_d (mm): drilling depth
n (rev/min): spindle speed

◆ Example

Drilling a hole with a diameter of 20mm and a depth of 40mm, cutting speed is 100m/min and feed rate per revolution is 0.1mm/rev. Calculate the drilling time.

$$n = \frac{V_c \times 1000}{D_c \times \pi} = \frac{100 \times 1000}{20 \times 3.14} = 1600 \text{ (rev/min)}$$

$$T_c = \frac{I_d \times i}{n \times f_r} = \frac{40 \times 1}{1600 \times 0.1} = 0.25 \text{ (min)}$$

Metal removal rate

$$Q = \frac{V_f \times \pi \times D_c^2}{4 \times 1000}$$

Q (cm³/min): metal removal rate
D_c (mm): drill diameter
V_f (mm/min): feed speed

◆ Example

Drill diameter is 20mm, feed speed is 160mm/rev, thus metal removal rate is:

$$Q = \frac{V_f \times \pi \times D_c^2}{4 \times 1000} = \frac{160 \times 3.14 \times 20^2}{4 \times 1000} = 50.24 \text{ (cm}^3\text{/min)}$$



Recommended cutting parameters for ZSD

ISO	Materials	Hardness HB	Diameter Dc mm	Feed rate fn mm/r	Cutting speed Vc m/min
P	Carbon steel	80-200	12.0-21.5 22.0-33.5 34.0-41.5 42.0-50.0	0.04-0.09 0.05-0.09 0.06-0.10 0.07-0.11	200(170-240)
	Low alloy steel	150-260	12.0-21.5 22.0-33.5 34.0-41.5 42.0-50.0	0.04-0.09 0.05-0.12 0.06-0.14 0.08-0.16	170(140-220)
	High alloy steel	150-320	12.0-21.5 22.0-33.5 34.0-41.5 42.0-50.0	0.04-0.09 0.05-0.12 0.06-0.16 0.08-0.18	150(120-180)
	Cast steel	180-250	12.0-21.5 22.0-33.5 34.0-41.5 42.0-50.0	0.04-0.08 0.05-0.08 0.06-0.10 0.07-0.11	140(120-170)
M	Stainless steel Ferrite Martensite	150-270	12.0-21.5 22.0-33.5 34.0-41.5 42.0-50.0	0.04-0.09 0.05-0.12 0.06-0.16 0.08-0.18	160(110-230)
	Austenite	150-275	12.0-21.5 22.0-33.5 34.0-41.5 42.0-50.0	0.04-0.09 0.05-0.11 0.06-0.13 0.08-0.14	140(110-220)
K	Malleable cast iron	150-230	12.0-21.5 22.0-33.5 34.0-41.5 42.0-50.0	0.04-0.10 0.05-0.14 0.08-0.16 0.10-0.20	160(120-220)
	Gray cast iron	150-220	12.0-21.5 22.0-33.5 34.0-41.5 42.0-50.0	0.04-0.10 0.05-0.14 0.08-0.16 0.10-0.20	200(170-240)
	Nodular cast iron	160-250	12.0-21.5 22.0-33.5 34.0-41.5 42.0-50.0	0.04-0.09 0.05-0.12 0.06-0.14 0.08-0.16	160(130-200)
N	Non ferrous metals	60-110	12.0-21.5 22.0-33.5 34.0-41.5 42.0-50.0	0.04-0.10 0.05-0.14 0.08-0.16 0.10-0.20	300(250-350)



Recommended cutting parameters for ZTD

ISO	Materials	Hardness HB	Diameter Dc mm	Feed rate fn mm/r	Cutting speed Vc m/min
P	Carbon steel	80-200	13.0-21.0	0.05-0.09	200(170-240)
			22.0-33.0	0.05-0.09	
			34.0-41.0	0.06-0.10	
			42.0-50.0	0.07-0.11	
	Low alloy steel	150-260	51.0-58.0	0.08-0.12	
			13.0-21.0	0.05-0.09	
			22.0-33.0	0.05-0.12	
			34.0-41.0	0.06-0.14	
	High alloy steel	150-320	42.0-50.0	0.08-0.16	
			51.0-58.0	0.10-0.20	
			13.0-21.0	0.05-0.09	
			22.0-33.0	0.05-0.12	
	Cast steel	180-250	34.0-41.0	0.06-0.16	
			42.0-50.0	0.08-0.18	
			51.0-58.0	0.10-0.22	
			13.0-21.0	0.05-0.08	
	Stainless steel Ferrite Martensite	150-270	22.0-33.0	0.05-0.08	
			34.0-41.0	0.05-0.08	
			42.0-50.0	0.06-0.10	
			51.0-58.0	0.07-0.11	
	Austenite	150-275	13.0-21.0	0.07-0.11	
			22.0-33.0	0.07-0.11	
			34.0-41.0	0.06-0.10	
			42.0-50.0	0.07-0.11	
	Malleable cast iron	150-230	51.0-58.0	0.07-0.11	
			13.0-21.0	0.05-0.10	
			22.0-33.0	0.05-0.14	
			34.0-41.0	0.08-0.16	
	Gray cast iron	150-220	42.0-50.0	0.10-0.20	
			51.0-58.0	0.12-0.24	
			13.0-21.0	0.05-0.10	
			22.0-33.0	0.05-0.14	
	Nodular cast iron	160-250	34.0-41.0	0.08-0.16	
			42.0-50.0	0.10-0.20	
			51.0-58.0	0.12-0.24	
			13.0-21.0	0.05-0.09	
	Non ferrous metals	60-110	22.0-33.0	0.05-0.12	
			34.0-41.0	0.06-0.14	
			42.0-50.0	0.08-0.16	
			51.0-58.0	0.10-0.20	

ZTK series



Interchangeable head drill

High-performance Interchangeable head drill with unique structure design, can reduce machining cost and improve production efficiency, Achieve high precision and high efficiency cutting.

➔ Double helical internal coolant holes, provide accurate cooling supply and good chip control during machining;

➔ Double clamping
Both axial, radial positioning surface and thread interface coordinately clamping to ensure stable and reliable tool head assembly;



➔ Unique cutting edge design, with good versatility can ensure smooth cutting, achieve low resistance and efficient machining.

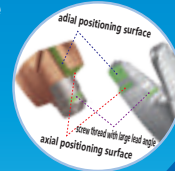

General-purpose machining-GD
The combination of curve and straight cutting edge generates good universality

For Cast Iron-KD
Enhanced cutting edge prolong tool life

For AL-LD
Low resistance design, achieve high efficiency cutting

Three types of drill-head, able to meet requirements for various materials, prolong tool life, achieve machining stability.

Case study

Excellent machining accuracy

Tool holder specification : ZTK03-ED125-G16C
Tool head specification : EDC1260-060-GD
Workpiece material: 42CrMo (HRC30)
Cutting data: $V_c=100\text{m/min}$;
 $f=0.20\text{mm/r}$; $ap=30\text{mm}$
Cooling type: internal coolant supply



ZTK Similar products of company A

Excellent chip-breaking performance

Tool holder specification: ZTK03-ED160-G20C
Tool head specification: EDC1630-080-GD
Workpiece material: 50Mn (HB240)
Cutting data: $V_c=120\text{m/min}$;
 $f=0.30\text{mm/r}$;
 $ap=30\text{mm}$
Cooling type: internal coolant supply

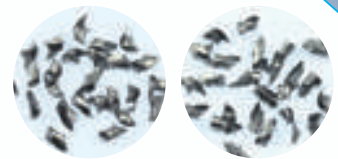

ZTK Similar products of company A

Conclusion: Under the same working conditions, the surface accuracy, verticality and chip breaking performance of our ZTK series interchangeable drill holes are better than similar products of Company A.



Code key of Interchangeable head drill tool holder

015	1.5D
03	3D
05	5D
08	8D
L/D	

Range	120-250
	12.0mm-25.0mm
Tool diameter	

Range	16
	20
	25
	32
Shank diameter	

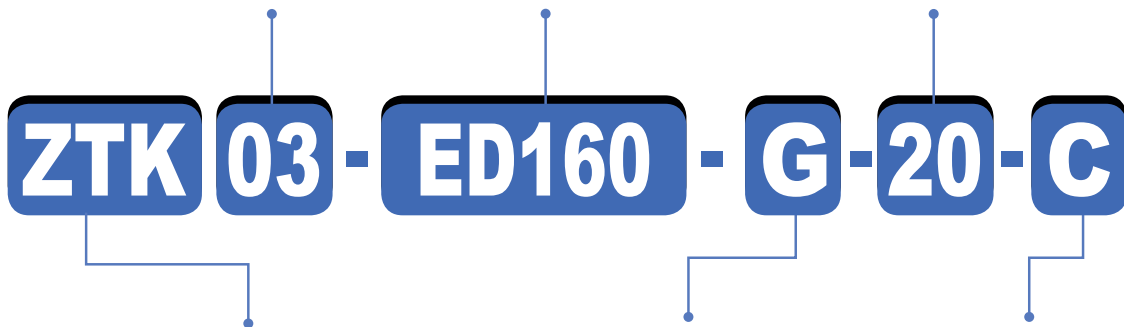

Tool type

Code	Description
ZTK	Interchangeable head drill

Shank type

Code	Description
G	Cylindrical shank
XP	Weldon shank

Internal identification

Code key of Interchangeable head drill head

Range	1200-2590
	12.0mm-25.9mm
Tool diameter	

GD	General machining
KD	Cast iron machining
LD	Aluminum machining
Application range	

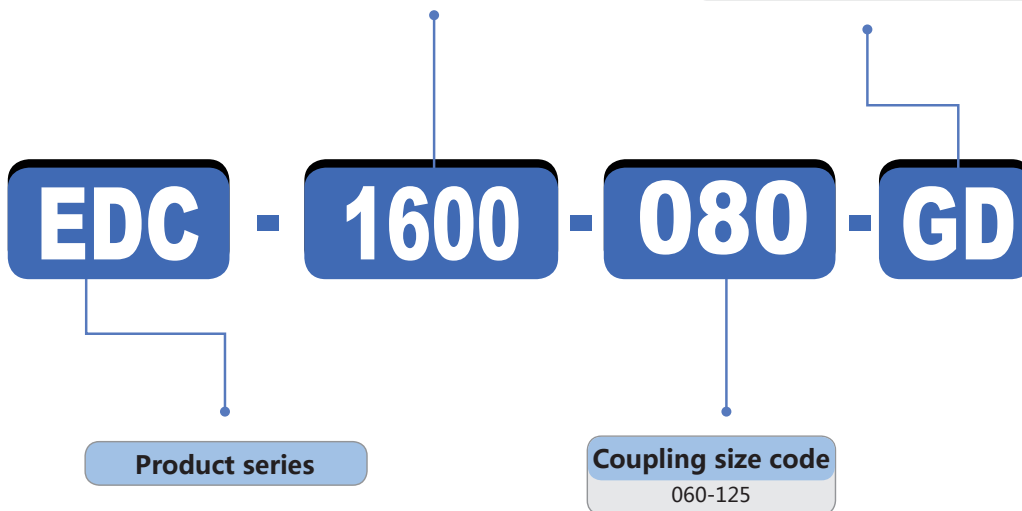

Product series

Coupling size code

060-125



Interchangeable head drills

Interchangeable head drill

ZTK015 1.5D

Used for shanks with 12.0mm – 25.9mm diameter drill head

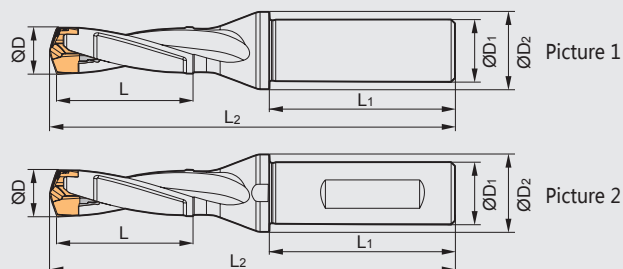

Type	Stock	Basic dimension(mm)						Coupling	Shank form	Wrench		
		ØD	L	ØD1	ØD2	L1	L2					
ZTK015 Cylindrical shank	▲	-ED120-G16C	▲	12-12.9	18.0	16	20	48	83.0	060	Picture 1	ZTK12-15.9
	▲	-ED130-G16C	▲	13-13.9	19.5	16	20	48	85.5	065	Picture 1	ZTK12-15.9
	▲	-ED140-G20C	▲	14-14.9	21.0	20	25	50	91.0	070	Picture 1	ZTK12-15.9
	▲	-ED150-G20C	▲	15-15.9	22.5	20	25	50	96.5	075	Picture 1	ZTK12-15.9
	▲	-ED160-G20C	▲	16-16.9	24.0	20	25	50	100.0	080	Picture 1	ZTK16-20.9
	▲	-ED170-G20C	▲	17-17.9	25.5	20	25	50	102.5	085	Picture 1	ZTK16-20.9
	▲	-ED180-G25C	▲	18-18.9	27.0	25	32	56	112.0	090	Picture 1	ZTK16-20.9
	▲	-ED190-G25C	▲	19-19.9	28.5	25	32	56	114.5	095	Picture 1	ZTK16-20.9
	▲	-ED200-G25C	▲	20-20.9	30.0	25	32	56	116.0	100	Picture 1	ZTK16-20.9
	▲	-ED210-G25C	▲	21-21.9	31.5	25	32	56	125.5	105	Picture 1	ZTK21-25.9
	▲	-ED220-G25C	▲	22-22.9	33.0	25	32	56	128.0	110	Picture 1	ZTK21-25.9
	▲	-ED230-G32C	▲	23-23.9	34.5	32	42	60	131.5	115	Picture 1	ZTK21-25.9
▲	-ED240-G32C	▲	24-24.9	36.0	32	42	60	134.0	120	Picture 1	ZTK21-25.9	
▲	-ED250-G32C	▲	25-25.9	37.5	32	42	60	137.5	125	Picture 1	ZTK21-25.9	
Weldon shank	▲	-ED120-XP16C	▲	12-12.9	18.0	16	20	48	83.0	060	Picture 2	ZTK12-15.9
	▲	-ED130-XP16C	▲	13-13.9	19.5	16	20	48	85.5	065	Picture 2	ZTK12-15.9
	▲	-ED140-XP20C	▲	14-14.9	21.0	20	25	50	91.0	070	Picture 2	ZTK12-15.9
	▲	-ED150-XP20C	▲	15-15.9	22.5	20	25	50	96.5	075	Picture 2	ZTK12-15.9
	▲	-ED160-XP20C	▲	16-16.9	24.0	20	25	50	100.0	080	Picture 2	ZTK16-20.9
	▲	-ED170-XP20C	▲	17-17.9	25.5	20	25	50	102.5	085	Picture 2	ZTK16-20.9
	▲	-ED180-XP25C	▲	18-18.9	27.0	25	32	56	112.0	090	Picture 2	ZTK16-20.9
	▲	-ED190-XP25C	▲	19-19.9	28.5	25	32	56	114.5	095	Picture 2	ZTK16-20.9
	▲	-ED200-XP25C	▲	20-20.9	30.0	25	32	56	116.0	100	Picture 2	ZTK16-20.9
	▲	-ED210-XP25C	▲	21-21.9	31.5	25	32	56	125.5	105	Picture 2	ZTK21-25.9
	▲	-ED220-XP25C	▲	22-22.9	33.0	25	32	56	128.0	110	Picture 2	ZTK21-25.9
	▲	-ED230-XP32C	▲	23-23.9	34.5	32	42	60	131.5	115	Picture 2	ZTK21-25.9
▲	-ED240-XP32C	▲	24-24.9	36.0	32	42	60	134.0	120	Picture 2	ZTK21-25.9	
▲	-ED250-XP32C	▲	25-25.9	37.5	32	42	60	137.5	125	Picture 2	ZTK21-25.9	

▲Regular Stock △Made-to-order

Drilling tools

Interchangeable head drills



Interchangeable head drill

ZTK03 3D

Used for shanks with 12.0mm – 25.9mm diameter drill head

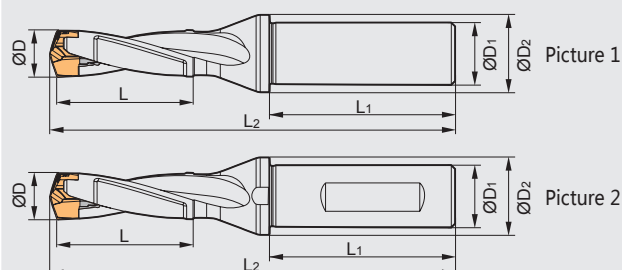

Type	Stock	Basic dimension(mm)						Coupling	Shank form	Wrench	
		ØD	L	ØD ₁	ØD ₂	L ₁	L ₂				
ZTK03 Cylindrical shank	▲ -ED120-G16C	▲	12-12.4	36.0	16	20	48	101.0	060	Picture 1	ZTK12-15.9
	▲ -ED125-G16C	▲	12.5-12.9	37.0	16	20	48	103.0	060	Picture 1	ZTK12-15.9
	▲ -ED130-G16C	▲	13-13.4	39.0	16	20	48	105.0	065	Picture 1	ZTK12-15.9
	▲ -ED135-G16C	▲	13.5-13.9	41.0	16	20	48	107.0	065	Picture 1	ZTK12-15.9
	▲ -ED140-G20C	▲	14-14.4	42.0	20	25	50	112.0	070	Picture 1	ZTK12-15.9
	▲ -ED145-G20C	▲	14.5-14.9	44.0	20	25	50	114.0	070	Picture 1	ZTK12-15.9
	▲ -ED150-G20C	▲	15-15.9	45.0	20	25	50	119.0	075	Picture 1	ZTK12-15.9
	▲ -ED160-G20C	▲	16-16.9	48.0	20	25	50	124.0	080	Picture 1	ZTK16-20.9
	▲ -ED170-G20C	▲	17-17.9	51.0	20	25	50	128.0	085	Picture 1	ZTK16-20.9
	▲ -ED180-G25C	▲	18-18.9	54.0	25	32	56	139.0	090	Picture 1	ZTK16-20.9
	▲ -ED190-G25C	▲	19-19.9	57.0	25	32	56	143.0	095	Picture 1	ZTK16-20.9
	▲ -ED200-G25C	▲	20-20.9	60.0	25	32	56	146.0	100	Picture 1	ZTK16-20.9
	▲ -ED210-G25C	▲	21-21.9	63.0	25	32	56	157.0	105	Picture 1	ZTK21-25.9
	▲ -ED220-G25C	▲	22-22.9	66.0	25	32	56	161.0	110	Picture 1	ZTK21-25.9
▲ -ED230-G32C	▲	23-23.9	69.0	32	42	60	166.0	115	Picture 1	ZTK21-25.9	
▲ -ED240-G32C	▲	24-24.9	72.0	32	42	60	170.0	120	Picture 1	ZTK21-25.9	
▲ -ED250-G32C	▲	25-25.9	75.0	32	42	60	175.0	125	Picture 1	ZTK21-25.9	
Weldon shank	▲ -ED120-XP16C	▲	12-12.4	36.0	16	20	48	101.0	060	Picture 2	ZTK12-15.9
	▲ -ED125-XP16C	▲	12.5-12.9	37.0	16	20	48	103.0	060	Picture 2	ZTK12-15.9
	▲ -ED130-XP16C	▲	13-13.4	39.0	16	20	48	105.0	065	Picture 2	ZTK12-15.9
	▲ -ED135-XP16C	▲	13.5-13.9	41.0	16	20	48	107.0	065	Picture 2	ZTK12-15.9
	▲ -ED140-XP20C	▲	14-14.4	42.0	20	25	50	112.0	070	Picture 2	ZTK12-15.9
	▲ -ED145-XP20C	▲	14.5-14.9	44.0	20	25	50	114.0	070	Picture 2	ZTK12-15.9
	▲ -ED150-XP20C	▲	15-15.9	45.0	20	25	50	119.0	075	Picture 2	ZTK12-15.9
	▲ -ED160-XP20C	▲	16-16.9	48.0	20	25	50	124.0	080	Picture 2	ZTK16-20.9
	▲ -ED170-XP20C	▲	17-17.9	51.0	20	25	50	128.0	085	Picture 2	ZTK16-20.9
	▲ -ED180-XP25C	▲	18-18.9	54.0	25	32	56	139.0	090	Picture 2	ZTK16-20.9
	▲ -ED190-XP25C	▲	19-19.9	57.0	25	32	56	143.0	095	Picture 2	ZTK16-20.9
	▲ -ED200-XP25C	▲	20-20.9	60.0	25	32	56	146.0	100	Picture 2	ZTK16-20.9
	▲ -ED210-XP25C	▲	21-21.9	63.0	25	32	56	157.0	105	Picture 2	ZTK21-25.9
	▲ -ED220-XP25C	▲	22-22.9	66.0	25	32	56	161.0	110	Picture 2	ZTK21-25.9
▲ -ED230-XP32C	▲	23-23.9	69.0	32	42	60	166.0	115	Picture 2	ZTK21-25.9	
▲ -ED240-XP32C	▲	24-24.9	72.0	32	42	60	170.0	120	Picture 2	ZTK21-25.9	
▲ -ED250-XP32C	▲	25-25.9	75.0	32	42	60	175.0	125	Picture 2	ZTK21-25.9	

▲Regular Stock △Made-to-order

Drilling tools

Interchangeable head drills



Interchangeable head drills

Interchangeable head drill

ZTK05 5D

Used for shanks with 12.0mm – 25.9mm diameter drill head

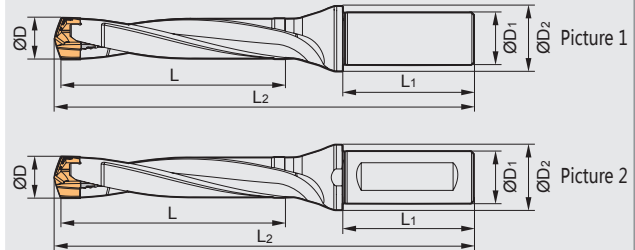

Type	Stock	Basic dimension(mm)						Coupling	Shank form	Wrench
		ØD	L	ØD ₁	ØD ₂	L ₁	L ₂			
Cylindrical shank	▲	12-12.4	60.0	16	20	48	125.0	060	Picture 1	ZTK12-15.9
	▲	12.5-12.9	62.0	16	20	48	128.0	060	Picture 1	ZTK12-15.9
	▲	13-13.4	65.0	16	20	48	131.0	065	Picture 1	ZTK12-15.9
	▲	13.5-13.9	68.0	16	20	48	134.0	065	Picture 1	ZTK12-15.9
	▲	14-14.4	70.0	20	25	50	141.0	070	Picture 1	ZTK12-15.9
	▲	14.5-14.9	73.0	20	25	50	143.0	070	Picture 1	ZTK12-15.9
	▲	15-15.9	75.0	20	25	50	149.0	075	Picture 1	ZTK12-15.9
	▲	16-16.9	80.0	20	25	50	156.0	080	Picture 1	ZTK16-20.9
	▲	17-17.9	85.0	20	25	50	162.0	085	Picture 1	ZTK16-20.9
	▲	18-18.9	90.0	25	32	56	175.0	090	Picture 1	ZTK16-20.9
	▲	19-19.9	95.0	25	32	56	181.0	095	Picture 1	ZTK16-20.9
	▲	20-20.9	100.0	25	32	56	188.0	100	Picture 1	ZTK16-20.9
	▲	21-21.9	105.0	25	32	56	199.0	105	Picture 1	ZTK21-25.9
	▲	22-22.9	110.0	25	32	56	205.0	110	Picture 1	ZTK21-25.9
▲	23-23.9	115.0	32	42	60	212.0	115	Picture 1	ZTK21-25.9	
Weldon shank	▲	12-12.4	60.0	16	20	48	125.0	060	Picture 2	ZTK12-15.9
	▲	12.5-12.9	62.0	16	20	48	128.0	060	Picture 2	ZTK12-15.9
	▲	13-13.4	65.0	16	20	48	131.0	065	Picture 2	ZTK12-15.9
	▲	13.5-13.9	68.0	16	20	48	134.0	065	Picture 2	ZTK12-15.9
	▲	14-14.4	70.0	20	25	50	141.0	070	Picture 2	ZTK12-15.9
	▲	14.5-14.9	73.0	20	25	50	143.0	070	Picture 2	ZTK12-15.9
	▲	15-15.9	75.0	20	25	50	149.0	075	Picture 2	ZTK12-15.9
	▲	16-16.9	80.0	20	25	50	156.0	080	Picture 2	ZTK16-20.9
	▲	17-17.9	85.0	20	25	50	162.0	085	Picture 2	ZTK16-20.9
	▲	18-18.9	90.0	25	32	56	175.0	090	Picture 2	ZTK16-20.9
	▲	19-19.9	95.0	25	32	56	181.0	095	Picture 2	ZTK16-20.9
	▲	20-20.9	100.0	25	32	56	188.0	100	Picture 2	ZTK16-20.9
	▲	21-21.9	105.0	25	32	56	199.0	105	Picture 2	ZTK21-25.9
	▲	22-22.9	110.0	25	32	56	205.0	110	Picture 2	ZTK21-25.9
▲	23-23.9	115.0	32	42	60	212.0	115	Picture 2	ZTK21-25.9	
▲	24-24.9	120.0	32	42	60	218.0	120	Picture 2	ZTK21-25.9	
▲	25-25.9	125.0	32	42	60	225.0	125	Picture 2	ZTK21-25.9	

▲Regular Stock △Made-to-order

Drilling tools

Interchangeable head drills



Interchangeable head drill

ZTK08 8D

Used for shanks with 12.0mm – 25.9mm diameter drill head

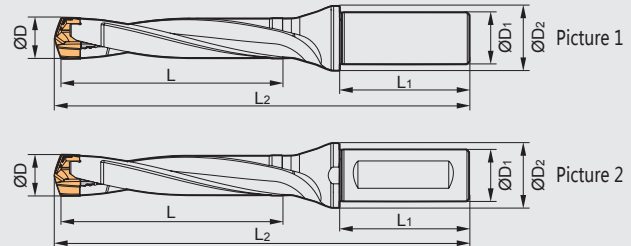

Type	Stock	Basic dimension(mm)						Coupling	Shank form	Wrench		
		ØD	L	ØD1	ØD2	L1	L2					
ZTK08 Cylindrical shank	▲	-ED120-G16C	▲	12-12.4	96.0	16	20	48	161.0	060	Picture 1	ZTK12-15.9
	▲	-ED125-G16C	▲	12.5-12.9	99.5	16	20	48	165.5	060	Picture 1	ZTK12-15.9
	▲	-ED130-G16C	▲	13-13.4	104.0	16	20	48	170.0	065	Picture 1	ZTK12-15.9
	▲	-ED135-G16C	▲	13.5-13.9	108.5	16	20	48	174.5	065	Picture 1	ZTK12-15.9
	▲	-ED140-G20C	▲	14-14.4	112.0	20	25	50	183.0	070	Picture 1	ZTK12-15.9
	▲	-ED145-G20C	▲	14.5-14.9	116.5	20	25	50	186.5	070	Picture 1	ZTK12-15.9
	▲	-ED150-G20C	▲	15-15.9	120.0	20	25	50	194.0	075	Picture 1	ZTK12-15.9
	▲	-ED160-G20C	▲	16-16.9	128.0	20	25	50	204.0	080	Picture 1	ZTK16-20.9
	▲	-ED170-G20C	▲	17-17.9	136.0	20	25	50	213.0	085	Picture 1	ZTK16-20.9
	▲	-ED180-G25C	▲	18-18.9	144.0	25	32	56	229.0	090	Picture 1	ZTK16-20.9
	▲	-ED190-G25C	▲	19-19.9	152.0	25	32	56	238.0	095	Picture 1	ZTK16-20.9
	▲	-ED200-G25C	▲	20-20.9	160.0	25	32	56	248.0	100	Picture 1	ZTK16-20.9
	▲	-ED210-G25C	▲	21-21.9	168.0	25	32	56	262.0	105	Picture 1	ZTK21-25.9
	▲	-ED220-G25C	▲	22-22.9	176.0	25	32	56	271.0	110	Picture 1	ZTK21-25.9
▲	-ED230-G32C	▲	23-23.9	184.0	32	42	60	281.0	115	Picture 1	ZTK21-25.9	
▲	-ED240-G32C	▲	24-24.9	192.0	32	42	60	290.0	120	Picture 1	ZTK21-25.9	
▲	-ED250-G32C	▲	25-25.9	200.0	32	42	60	300.0	125	Picture 1	ZTK21-25.9	
Weldon shank	▲	-ED120-XP16C	▲	12-12.4	96.0	16	20	48	161.0	060	Picture 2	ZTK12-15.9
	▲	-ED125-XP16C	▲	12.5-12.9	99.5	16	20	48	165.5	060	Picture 2	ZTK12-15.9
	▲	-ED130-XP16C	▲	13-13.4	104.0	16	20	48	170.0	065	Picture 2	ZTK12-15.9
	▲	-ED135-XP16C	▲	13.5-13.9	108.5	16	20	48	174.5	065	Picture 2	ZTK12-15.9
	▲	-ED140-XP20C	▲	14-14.4	112.0	20	25	50	183.8	070	Picture 2	ZTK12-15.9
	▲	-ED145-XP20C	▲	14.5-14.9	116.5	20	25	50	186.5	070	Picture 2	ZTK12-15.9
	▲	-ED150-XP20C	▲	15-15.9	120.0	20	25	50	194.0	075	Picture 2	ZTK12-15.9
	▲	-ED160-XP20C	▲	16-16.9	128.0	20	25	50	204.0	080	Picture 2	ZTK16-20.9
	▲	-ED170-XP20C	▲	17-17.9	136.0	20	25	50	213.0	085	Picture 2	ZTK16-20.9
	▲	-ED180-XP25C	▲	18-18.9	144.0	25	32	56	229.0	090	Picture 2	ZTK16-20.9
	▲	-ED190-XP25C	▲	19-19.9	152.0	25	32	56	238.0	095	Picture 2	ZTK16-20.9
	▲	-ED200-XP25C	▲	20-20.9	160.0	25	32	56	248.0	100	Picture 2	ZTK16-20.9
	▲	-ED210-XP25C	▲	21-21.9	168.0	25	32	56	262.0	105	Picture 2	ZTK21-25.9
	▲	-ED220-XP25C	▲	22-22.9	176.0	25	32	56	271.0	110	Picture 2	ZTK21-25.9
▲	-ED230-XP32C	▲	23-23.9	184.0	32	42	60	281.0	115	Picture 2	ZTK21-25.9	
▲	-ED240-XP32C	▲	24-24.9	192.0	32	42	60	290.0	120	Picture 2	ZTK21-25.9	
▲	-ED250-XP32C	▲	25-25.9	200.0	32	42	60	300.0	125	Picture 2	ZTK21-25.9	

▲Regular Stock △Made-to-order



BORING TOOL / Drilling Tools

Interchangeable head drills

EDC Interchangeable head drill

Diameter 12.0mm – 25.9mm

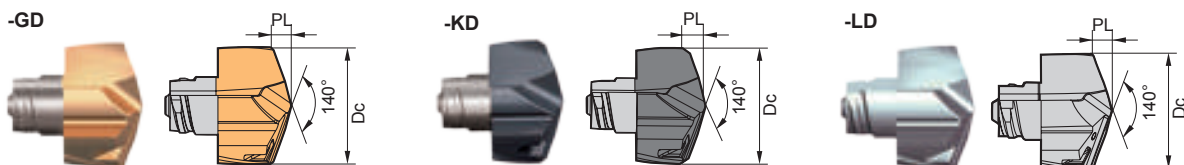

Type	Grade	Basic dimension(mm)		Compatible tool holder	Coupling	Wrench
	KDG3013	Dc	PL			
EDC1200-060-GD/KD/LD	▲	12.0	2.18	ZTK015-ED120-□□ ZTK03-ED120-□□ ZTK05-ED120-□□ ZTK08-ED120-□□	060	ZTK12-15.9
EDC1210-060-GD/KD/LD	△	12.1	2.20			
EDC1220-060-GD/KD/LD	△	12.2	2.22			
EDC1230-060-GD/KD/LD	△	12.3	2.24			
EDC1240-060-GD/KD/LD	△	12.4	2.26			
EDC1250-060-GD/KD/LD	▲	12.5	2.27	ZTK015-ED120-□□ ZTK03-ED125-□□ ZTK05-ED125-□□ ZTK08-ED125-□□		
EDC1260-060-GD/KD/LD	△	12.6	2.29			
EDC1270-060-GD/KD/LD	△	12.7	2.31			
EDC1280-060-GD/KD/LD	△	12.8	2.33			
EDC1290-060-GD/KD/LD	△	12.9	2.35			
EDC1300-065-GD/KD/LD	▲	13.0	2.36	ZTK015-ED130-□□ ZTK03-ED130-□□ ZTK05-ED130-□□ ZTK08-ED130-□□	065	
EDC1310-065-GD/KD/LD	△	13.1	2.38			
EDC1320-065-GD/KD/LD	△	13.2	2.40			
EDC1330-065-GD/KD/LD	△	13.3	2.42			
EDC1340-065-GD/KD/LD	△	13.4	2.44			
EDC1350-065-GD/KD/LD	▲	13.5	2.46	ZTK015-ED130-□□ ZTK03-ED135-□□ ZTK05-ED135-□□ ZTK08-ED135-□□		
EDC1360-065-GD/KD/LD	△	13.6	2.47			
EDC1370-065-GD/KD/LD	△	13.7	2.49			
EDC1380-065-GD/KD/LD	△	13.8	2.51			
EDC1390-065-GD/KD/LD	△	13.9	2.53			
EDC1400-070-GD/KD/LD	▲	14.0	2.55	ZTK015-ED140-□□ ZTK03-ED140-□□ ZTK05-ED140-□□ ZTK08-ED140-□□	070	
EDC1410-070-GD/KD/LD	△	14.1	2.56			
EDC1420-070-GD/KD/LD	△	14.2	2.58			
EDC1430-070-GD/KD/LD	△	14.3	2.60			
EDC1440-070-GD/KD/LD	△	14.4	2.62			
EDC1450-070-GD/KD/LD	▲	14.5	2.64	ZTK015-ED140-□□ ZTK03-ED145-□□ ZTK05-ED145-□□ ZTK08-ED145-□□		
EDC1460-070-GD/KD/LD	△	14.6	2.66			
EDC1470-070-GD/KD/LD	△	14.7	2.67			
EDC1480-070-GD/KD/LD	△	14.8	2.69			
EDC1490-070-GD/KD/LD	△	14.9	2.71			

▲Regular Stock △Made-to-order

Drilling tools

Interchangeable head drills



Type	Grade	Basic dimension(mm)		Compatible tool holder	Coupling	Wrench
	KDG3013	Dc	PL			
EDC1500-075-GD/KD/LD	▲	15.0	2.73	ZTK015-ED150-□□ ZTK03-ED150-□□ ZTK05-ED150-□□ ZTK08-ED150-□□	075	ZTK12-15.9
EDC1510-075-GD/KD/LD	△	15.1	2.75			
EDC1520-075-GD/KD/LD	△	15.2	2.76			
EDC1530-075-GD/KD/LD	△	15.3	2.78			
EDC1540-075-GD/KD/LD	△	15.4	2.80			
EDC1550-075-GD/KD/LD	▲	15.5	2.82			
EDC1560-075-GD/KD/LD	△	15.6	2.84			
EDC1570-075-GD/KD/LD	△	15.7	2.86			
EDC1580-075-GD/KD/LD	△	15.8	2.87			
EDC1590-075-GD/KD/LD	△	15.9	2.89			
EDC1600-080-GD/KD/LD	▲	16.0	2.91	ZTK015-ED160-□□ ZTK03-ED160-□□ ZTK05-ED160-□□ ZTK08-ED160-□□	080	ZTK16-20.9
EDC1610-080-GD/KD/LD	△	16.1	2.93			
EDC1620-080-GD/KD/LD	△	16.2	2.95			
EDC1630-080-GD/KD/LD	△	16.3	2.96			
EDC1640-080-GD/KD/LD	△	16.4	2.98			
EDC1650-080-GD/KD/LD	▲	16.5	3.00			
EDC1660-080-GD/KD/LD	△	16.6	3.02			
EDC1670-080-GD/KD/LD	△	16.7	3.04			
EDC1680-080-GD/KD/LD	△	16.8	3.06			
EDC1690-080-GD/KD/LD	△	16.9	3.07			
EDC1700-085-GD/KD/LD	▲	17.0	3.09	ZTK015-ED170-□□ ZTK03-ED170-□□ ZTK05-ED170-□□ ZTK08-ED170-□□	085	ZTK16-20.9
EDC1710-085-GD/KD/LD	△	17.1	3.11			
EDC1720-085-GD/KD/LD	△	17.2	3.13			
EDC1730-085-GD/KD/LD	△	17.3	3.15			
EDC1740-085-GD/KD/LD	△	17.4	3.16			
EDC1750-085-GD/KD/LD	▲	17.5	3.18			
EDC1760-085-GD/KD/LD	△	17.6	3.20			
EDC1770-085-GD/KD/LD	△	17.7	3.22			
EDC1780-085-GD/KD/LD	△	17.8	3.24			
EDC1790-085-GD/KD/LD	△	17.9	3.26			
EDC1800-090-GD/KD/LD	▲	18.0	3.27	ZTK015-ED180-□□ ZTK03-ED180-□□ ZTK05-ED180-□□ ZTK08-ED180-□□	090	ZTK16-20.9
EDC1810-090-GD/KD/LD	△	18.1	3.29			
EDC1820-090-GD/KD/LD	△	18.2	3.31			
EDC1830-090-GD/KD/LD	△	18.3	3.33			

▲Regular Stock △Made-to-order

Drilling tools

Interchangeable head drills

➤ Applicable material table

◎Very suitable ○Suitable

Workpiece material										
Mild steel HB≤180	Carbon steel, Alloy steel	Pre-hardened steel, Hardened steel			Stainless steel	Cast iron	Nodular cast iron	Aluminum alloy	Copper alloy	Heat resistant alloy
		~40HRC	~50HRC	~60HRC						
○	◎	◎			○	◎	◎	◎		



Interchangeable head drills

EDC Interchangeable head drill

Diameter 12.0mm – 25.9mm

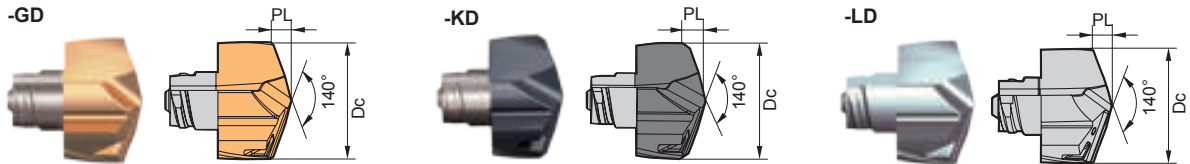

Type	Grade	Basic dimension(mm)		Compatible tool holder	Coupling	Wrench
	KDG3013	Dc	PL			
EDC1840-090-GD/KD/LD	△	18.4	3.35	ZTK015-ED180-□□ ZTK03-ED180-□□ ZTK05-ED180-□□ ZTK08-ED180-□□	090	ZTK16-20.9
EDC1850-090-GD/KD/LD	▲	18.5	3.36			
EDC1860-090-GD/KD/LD	△	18.6	3.38			
EDC1870-090-GD/KD/LD	△	18.7	3.40			
EDC1880-090-GD/KD/LD	△	18.8	3.42			
EDC1890-090-GD/KD/LD	△	18.9	3.44			
EDC1900-095-GD/KD/LD	▲	19.0	3.46	ZTK015-ED190-□□ ZTK03-ED190-□□ ZTK05-ED190-□□ ZTK08-ED190-□□	095	
EDC1910-095-GD/KD/LD	△	19.1	3.47			
EDC1920-095-GD/KD/LD	△	19.2	3.49			
EDC1930-095-GD/KD/LD	△	19.3	3.51			
EDC1940-095-GD/KD/LD	△	19.4	3.53			
EDC1950-095-GD/KD/LD	▲	19.5	3.55			
EDC1960-095-GD/KD/LD	△	19.6	3.56	ZTK015-ED200-□□ ZTK03-ED200-□□ ZTK05-ED200-□□ ZTK08-ED200-□□	100	
EDC1970-095-GD/KD/LD	△	19.7	3.58			
EDC1980-095-GD/KD/LD	△	19.8	3.60			
EDC1990-095-GD/KD/LD	△	19.9	3.62			
EDC2000-100-GD/KD/LD	▲	20.0	3.64			
EDC2010-100-GD/KD/LD	△	20.1	3.66			
EDC2020-100-GD/KD/LD	△	20.2	3.67	ZTK015-ED210-□□ ZTK03-ED210-□□ ZTK05-ED210-□□ ZTK08-ED210-□□	105	
EDC2030-100-GD/KD/LD	△	20.3	3.69			
EDC2040-100-GD/KD/LD	△	20.4	3.71			
EDC2050-100-GD/KD/LD	▲	20.5	3.73			
EDC2060-100-GD/KD/LD	△	20.6	3.75			
EDC2070-100-GD/KD/LD	△	20.7	3.77			
EDC2080-100-GD/KD/LD	△	20.8	3.78			
EDC2090-100-GD/KD/LD	△	20.9	3.80			
EDC2100-105-GD/KD/LD	▲	21.0	3.82			
EDC2110-105-GD/KD/LD	△	21.1	3.84			
EDC2120-105-GD/KD/LD	△	21.2	3.86			
EDC2130-105-GD/KD/LD	△	21.3	3.88			
EDC2140-105-GD/KD/LD	△	21.4	3.89			

▲Regular Stock △Made-to-order

Drilling tools

Interchangeable head drills



Type	Grade	Basic dimension(mm)		Compatible tool holder	Coupling	Wrench
	KDG3013	Dc	PL			
EDC2150-105-GD/KD/LD	▲	21.5	3.91	ZTK015-ED210-□□ ZTK03-ED210-□□ ZTK05-ED210-□□ ZTK08-ED210-□□	105	ZTK21-25.9
EDC2160-105-GD/KD/LD	△	21.6	3.93			
EDC2170-105-GD/KD/LD	△	21.7	3.95			
EDC2180-105-GD/KD/LD	△	21.8	3.97			
EDC2190-105-GD/KD/LD	△	21.9	3.98			
EDC2200-110-GD/KD/LD	▲	22.0	4.00	ZTK015-ED220-□□ ZTK03-ED220-□□ ZTK05-ED220-□□ ZTK08-ED220-□□	110	
EDC2210-110-GD/KD/LD	△	22.1	4.02			
EDC2220-110-GD/KD/LD	△	22.2	4.04			
EDC2230-110-GD/KD/LD	△	22.3	4.06			
EDC2240-110-GD/KD/LD	△	22.4	4.08			
EDC2250-110-GD/KD/LD	▲	22.5	4.09			
EDC2260-110-GD/KD/LD	△	22.6	4.11			
EDC2270-110-GD/KD/LD	△	22.7	4.13			
EDC2280-110-GD/KD/LD	△	22.8	4.15			
EDC2290-110-GD/KD/LD	△	22.9	4.17			
EDC2300-115-GD/KD/LD	▲	23.0	4.18	ZTK015-ED230-□□ ZTK03-ED230-□□ ZTK05-ED230-□□ ZTK08-ED230-□□	115	
EDC2310-115-GD/KD/LD	△	23.1	4.20			
EDC2320-115-GD/KD/LD	△	23.2	4.22			
EDC2330-115-GD/KD/LD	△	23.3	4.24			
EDC2340-115-GD/KD/LD	△	23.4	4.26			
EDC2350-115-GD/KD/LD	▲	23.5	4.27			
EDC2360-115-GD/KD/LD	△	23.6	4.29			
EDC2370-115-GD/KD/LD	△	23.7	4.31			
EDC2380-115-GD/KD/LD	△	23.8	4.33			
EDC2390-115-GD/KD/LD	△	23.9	4.35			

▲Regular Stock △Made-to-order

Drilling tools

Interchangeable head drills

➤ Applicable material table

⊙Very suitable ○Suitable

Workpiece material										
Mild steel HB≤180	Carbon steel, Alloy steel	Pre-hardened steel, Hardened steel			Stainless steel	Cast iron	Nodular cast iron	Aluminum alloy	Copper alloy	Heat resistant alloy
		~40HRC	~50HRC	~60HRC						
○	⊙	⊙			○	⊙	⊙	⊙		



BORING TOOL / Drilling Tools

Interchangeable head drills

EDC Interchangeable head drill

Diameter 12.0mm – 25.9mm

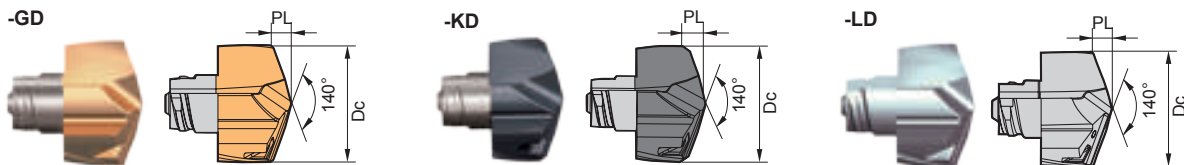

Type	Grade	Basic dimension(mm)		Compatible tool holder	Coupling	Wrench
	KDG3013	Dc	PL			
EDC2400-120-GD/KD/LD	▲	24.0	4.37	ZTK015-ED240-□□ ZTK03-ED240-□□ ZTK05-ED240-□□ ZTK08-ED240-□□	120	ZTK21-25.9
EDC2410-120-GD/KD/LD	△	24.1	4.38			
EDC2420-120-GD/KD/LD	△	24.2	4.40			
EDC2430-120-GD/KD/LD	△	24.3	4.42			
EDC2440-120-GD/KD/LD	△	24.4	4.44			
EDC2450-120-GD/KD/LD	▲	24.5	4.46			
EDC2460-120-GD/KD/LD	△	24.6	4.48			
EDC2470-120-GD/KD/LD	△	24.7	4.49			
EDC2480-120-GD/KD/LD	△	24.8	4.51			
EDC2490-120-GD/KD/LD	△	24.9	4.53			
EDC2500-125-GD/KD/LD	▲	25.0	4.55	ZTK015-ED250-□□ ZTK03-ED250-□□ ZTK05-ED250-□□ ZTK08-ED250-□□	125	ZTK21-25.9
EDC2510-125-GD/KD/LD	△	25.1	4.57			
EDC2520-125-GD/KD/LD	△	25.2	4.58			
EDC2530-125-GD/KD/LD	△	25.3	4.60			
EDC2540-125-GD/KD/LD	△	25.4	4.62			
EDC2550-125-GD/KD/LD	▲	25.5	4.64			
EDC2560-125-GD/KD/LD	△	25.6	4.66			
EDC2570-125-GD/KD/LD	△	25.7	4.68			
EDC2580-125-GD/KD/LD	△	25.8	4.69			
EDC2590-125-GD/KD/LD	△	25.9	4.70			

▲Regular Stock △Made-to-order

Drilling tools

Interchangeable head drills

Applicable material table

⊙Very suitable ○Suitable

Workpiece material										
Mild steel HB≤180	Carbon steel, Alloy steel	Pre-hardened steel, Hardened steel			Stainless steel	Cast iron	Nodular cast iron	Aluminum alloy	Copper alloy	Heat resistant alloy
		~40HRC	~50HRC	~60HRC						
○	⊙	⊙			○	⊙	⊙	⊙		



● **Geometry selection and hole tolerance**

Geometry	-GD				-KD				-LD			
Workpiece materials application ranges												
L/D	1.5D、3D、5D		8D		1.5D、3D、5D		8D		1.5D、3D、5D		8D	
	12-18mm	18-26mm	12-18mm	18-26mm	12-18mm	18-26mm	12-18mm	18-26mm	12-18mm	18-26mm	12-18mm	18-26mm
Tolerance of hole	0/+0.043	0/+0.052	0/+0.070	0/+0.084	0/+0.043	0/+0.052	0/+0.070	0/+0.084	0/+0.043	0/+0.052	0/+0.070	0/+0.084

● **Cooling requirements**

Internal coolant supply	External coolant supply (Drilling depth < 2D)	No dry cutting

● **User guide for drills with 8D shanks**

1 Pre-drilling with standard 1.5xD drills, hole depth: 0.5D~1.5D;

2 Drill to 2~5mm below the bottom of the pre-bored hold with slow feed, start drilling with normal parameters, turn on the internal coolant and hovering for 2~3 seconds ;

3 Start drilling with normal parameters.

Assembly instructions :

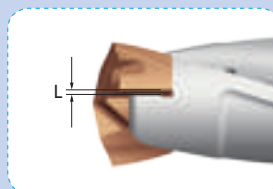

There will be a gap on radial direction after tightening with wrench L=0.05 ~ 0.1mm(the gap will be eliminated in cutting automatically).

After inserting the tip into the shanks, tighten it with a wrench. When removing, turn the wrench in the opposite direction.

Maximum deviation in assembly :

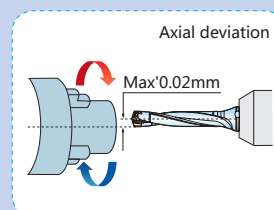
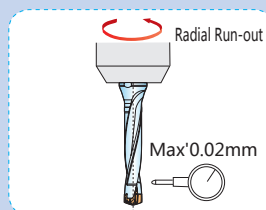



● Suitable workpiece shape

Processing content	Workpiece	Points for attention during processing
Plane surface		<ol style="list-style-type: none"> 1. For Stainless steel machining, suggest set up feed rate below 0.15mm/rev from entrance to 0.5D depth position; 2. In order to removal chip, suggest internal cooling, Recommend internal coolant for better chip control, combine internal and external coolant when machining stainless steel materials.
Overlapping plate		<ol style="list-style-type: none"> 1. In order to prevent dislocation, when processing the overlapping plate, The workpieces needed to be fixed.
Concave hole		<ol style="list-style-type: none"> 1. There could be interrupted cuts, suggest to set feed rate under half of the recommended cutting parameters before peripheral edges fully entering the hole; 2. Fine adjustment are recommened when long chips appearing at entrance.
Cylindrical surface hole		<ol style="list-style-type: none"> 1. It can be used for hole machining on the central axis of the shaft. 2. The curve part not recommend. <div style="display: flex; justify-content: space-around; align-items: center;"> <div style="text-align: center;"> <p>Center part machining</p> </div> <div style="text-align: center;"> <p>Curve part machining</p> </div> </div>

Drilling tools

Interchangeable head drills

● Workpiece shape not recommend

Processing content	Overlapped hole	Slope	Half-section	Reaming
workpiece shape				



Recommended cutting parameters of Interchangeable drills

Workpiece materials	Cutting speed (m/min)	Diameter (mm)											
		12		14		16		18		20		25	
		Revolution speed min ⁻¹	Feed rate mm/r	Revolution speed min ⁻¹	Feed rate mm/r	Revolution speed min ⁻¹	Feed rate mm/r	Revolution speed min ⁻¹	Feed rate mm/r	Revolution speed min ⁻¹	Feed rate mm/r	Revolution speed min ⁻¹	Feed rate mm/r
P Soft steel HB≤180	80-150	3200	0.20~0.30	2700	0.22~0.35	2400	0.25~0.36	2100	0.28~0.38	1900	0.30~0.40	1500	0.32~0.42
		3200	0.20~0.30	2700	0.22~0.35	2400	0.25~0.36	2100	0.28~0.38	1900	0.30~0.40	1500	0.32~0.42
	Carbon steel Alloy steel ~30HRC	80-150	3200	0.20~0.30	2700	0.22~0.35	2400	0.25~0.36	2100	0.28~0.38	1900	0.30~0.40	1500
Pre-hardened steel ~40HRC	50-80	1900	0.20~0.30	1600	0.22~0.35	1400	0.25~0.36	1200	0.28~0.38	1100	0.30~0.40	900	0.32~0.42
M Stainless steel	50-80	1600	0.12~0.20	1300	0.13~0.22	1200	0.14~0.25	1050	0.15~0.28	950	0.16~0.30	700	0.17~0.32
K Cast iron	80-150	3200	0.20~0.30	2700	0.22~0.35	2400	0.25~0.36	2100	0.28~0.38	1900	0.30~0.40	1500	0.32~0.42
	Nodular cast iron	60-120	2400	0.20~0.30	2100	0.22~0.35	1800	0.25~0.36	1600	0.28~0.38	1400	0.30~0.40	1100
N Aluminum alloy	90-200	4000	0.25~0.35	3400	0.28~0.38	3000	0.30~0.40	2600	0.33~0.43	2400	0.35~0.45	2000	0.40~0.50

Note: please set feed rate below to the recommendation parameter referring to the drill head diameters increasing(1.5D→3D→5D→8D).

Criteria: for 1.5D, 3D, 5D=80% or below, 8D=60% or below.

Cooling: adopt internal cooling or external cooling drilling no more than 2D, dry cutting is prohibited!



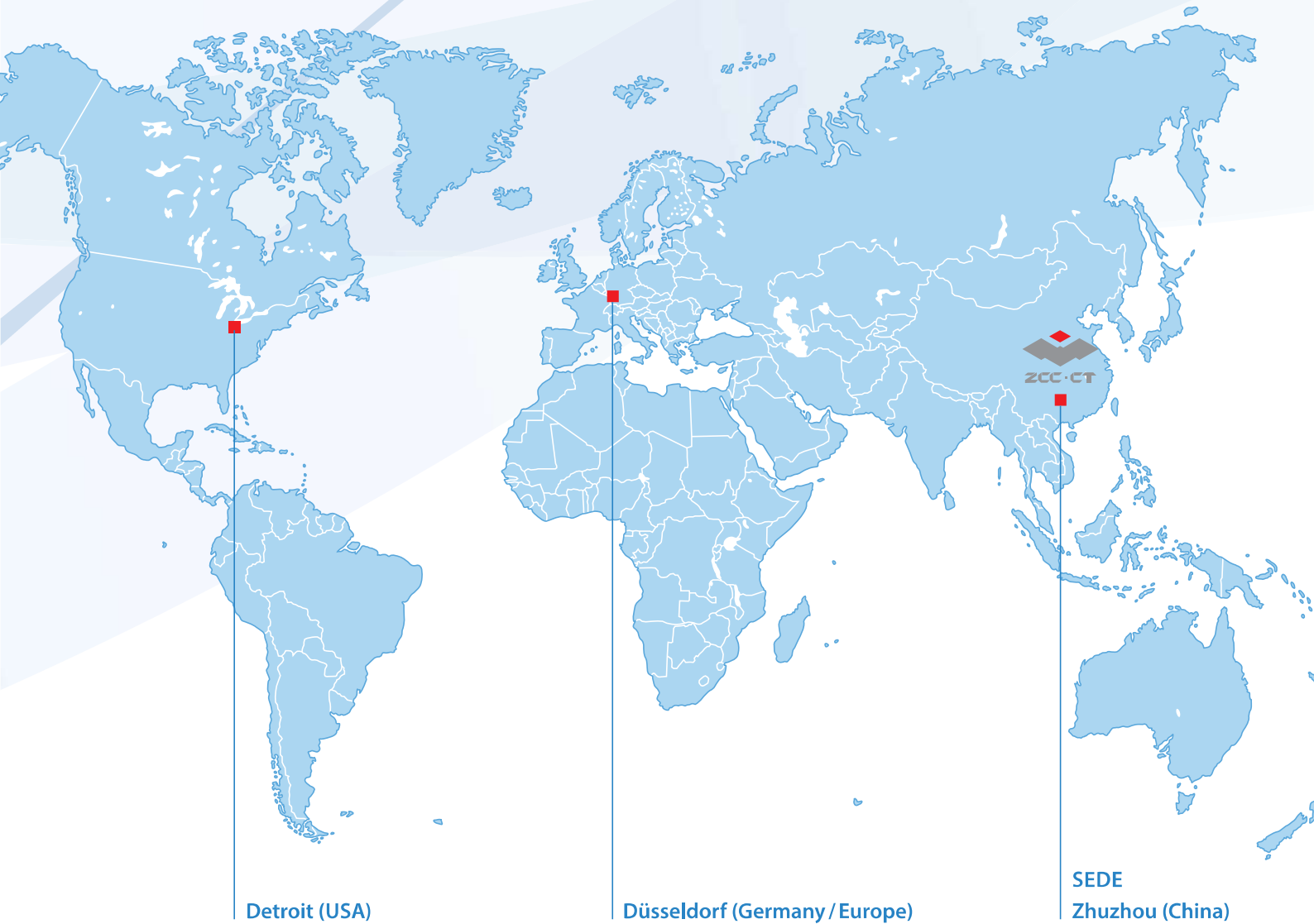

Detroit (USA)

Düsseldorf (Germany / Europe)

SEDE
Zhuzhou (China)





Oficina central europea

ZCC Cutting Tools Europe GmbH

www.zccct-europe.com

Wanheimer Str. 57, 40472 Düsseldorf, Germany

Tel.: +49 (0)211-989240-0

Fax: +49 (0)211-989240-111

E-mail: info@zccct-europe.com

Sucursal de Francia

ZCC Cutting Tools Europe GmbH

Succursale Française

www.zccct-europe.com

14, Allée Charles Pathé, 18000 Bourges, France

Tel.: +33 (0)2 45 41 01 40

Fax: +33 (0)800 74 27 27

E-mail: ventes@zccct-europe.com